



AIRPORT TRAFFIC CONTROL TOWER  
 MAJOR IMPROVEMENTS  
 FORT LAUDERDALE INTERNATIONAL  
 FT. LAUDERDALE, FL.

JANUARY 31, 2020



REV		APPROVED DATE	DESCRIPTION	JCN	REDLINE DATE	APVD

SCALES SHOWN FOR 22" X 34" SHEET. ADJUST SCALES FOR OTHER SIZES. PAGE **01** OF **01**

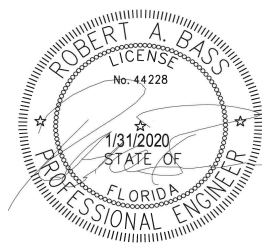

**WileyWilson**  
 5901 Peachtree Dunwoody Rd.  
 Bldg. C, Ste 515  
 Atlanta, Georgia 30328-6055  
 678.320.1888  
 wileywilson.com  
 WW JOB NUMBER: 219075.00

DEPARTMENT OF TRANSPORTATION  
 FEDERAL AVIATION ADMINISTRATION  
 FORT LAUDERDALE AIRPORT TRAFFIC CONTROL TOWER  
 MAJOR IMPROVEMENTS  
 GENERAL  
 COVER SHEET  
 FT LAUDERDALE (INTERNATIONAL) FL

REVIEWED BY	SUBMITTED BY	APPROVED BY
DESIGNED	ISSUED BY	DATE
DRAWN	ATLANTA TERMINAL ENGINEERING CENTER	JAN 31, 2020
CHECKED		JCN 1508912
		DRAWING NO
		FLL-D-TOWB-G000
		REV



DRAWING NUMBER

ATCT  
GENERAL

FLL-D-ATCT-G000

TITLE

COVER SHEET

DEMOLITION

FLL-D-ATCT-D100 ARCHITECTURAL - GROUND LEVEL AND SECOND LEVEL DEMOLITION  
 FLL-D-ATCT-D101 ARCHITECTURAL - CABLE ACCESS PLAN AND SUBJUNCTION LEVEL 2 DEMOLITION  
 FLL-D-ATCT-D102 ARCHITECTURAL - SUBJUNCTION LEVEL 1 AND JUNCTION LEVEL DEMOLITION  
 FLL-D-ATCT-D103 ARCHITECTURAL - CAB FLOOR AND ROOF PLANS DEMOLITION  
 FLL-D-ATCT-D300 MECHANICAL - GROUND LEVEL AND SUBJUNCTION LEVEL 2 DEMOLITION  
 FLL-D-ATCT-D301 MECHANICAL - SUBJUNCTION LEVEL 1 AND JUNCTION LEVEL DEMOLITION  
 FLL-D-ATCT-D400 PLUMBING - GROUND LEVEL PLAN - DEMOLITION  
 FLL-D-ATCT-D500 ELECTRICAL - GROUND LEVEL AND SUBJUNCTION LEVEL 2 DEMOLITION  
 FLL-D-ATCT-D501 ELECTRICAL - SUBJUNCTION LEVEL 1 AND JUNCTION LEVEL DEMOLITION

ARCHITECTURAL

FLL-D-ATCT-A000 LEGEND, SYMBOLS AND GENERAL NOTES  
 FLL-D-ATCT-A100 GROUND LEVEL AND SECOND LEVEL PLAN  
 FLL-D-ATCT-A101 CABLE ACCESS PLAN AND SUBJUNCTION LEVEL 2  
 FLL-D-ATCT-A102 SUBJUNCTION LEVEL 1 AND JUNCTION LEVEL  
 FLL-D-ATCT-A103 CAB LEVEL FLOOR AND ROOF PLANS  
 FLL-D-ATCT-A121 CABLE ACCESS 7TH LEVEL - RCP  
 FLL-D-ATCT-A500 FINISH SCHEDULE AND COLOR SELECTIONS  
 FLL-D-ATCT-A505 DOOR TYPES, SCHEDULE AND DETAILS  
 FLL-D-ATCT-A610 CATWALK AND CAB ROOF DETAILS  
 FLL-D-ATCT-A611 CATWALK HATCH AND CAB DETAILS

MECHANICAL

FLL-D-ATCT-M100 GROUND LEVEL AND SUBJUNCTION LEVEL 2 - HVAC  
 FLL-D-ATCT-M101 SUBJUNCTION LEVEL 1 AND JUNCTION LEVEL - HVAC  
 FLL-D-ATCT-M500 HVAC SCHEDULES  
 FLL-D-ATCT-M800 CONTROL SYSTEM DIAGRAM FOR AHUs-T1/T1B, T4/T4B  
 FLL-D-ATCT-M801 SEQUENCE OF OPERATION AND SYSTEM POINT SYSTEM  
 FLL-D-ATCT-M802 CONTROL SYSTEM DIAGRAM FOR FCU-T2 AND FCU-T3

PLUMBING



FLL-D-ATCT-P400 GROUND LEVEL PLAN - NEW WORK

ELECTRICAL

FLL-D-ATCT-E120 GROUND LEVEL POWER PLAN - NEW WORK  
 FLL-D-ATCT-E121 SUBJUNCTION LEVEL 2 POWER PLAN - NEW WORK  
 FLL-D-ATCT-E122 SUBJUNCTION LEVEL 1 AND JUNCTION LEVEL - NEW WORK  
 FLL-D-ATCT-E160 CAB LEVEL ROOF PLAN - LIGHTNING PROTECTION  
 FLL-D-ATCT-E500 PANEL SCHEDULES  
 FLL-D-ATCT-E501 PANEL SCHEDULES

FIRE PROTECTION

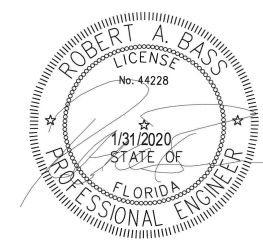
FLL-D-ATCT-F101 GROUND LEVEL AND CABLE ACCESS LEVEL 1 PLANS  
 FLL-D-ATCT-F102 CABLE ACCESS (TYPICAL) AND SUBJUNCTION LEVEL 2 PLANS  
 FLL-D-ATCT-F103 SUBJUNCTION LEVEL 1 AND JUNCTION LEVEL PLANS  
 FLL-D-ATCT-F501 DETAILS

SCALES SHOWN FOR 22" X 34" SHEET. ADJUST SCALES FOR OTHER SIZES.		PAGE	OF
		REV	APPROVED DATE
 <p><b>WileyWilson</b>                  5901 Peachtree Dunwoody Rd.                  Bldg. C, Ste 515                  Atlanta, Georgia 30328-6055                  678.320.1888                  wileywilson.com</p>		DESCRIPTION	JCN
FT LAUDERDALE (INTERNATIONAL) FL		DATE	REDLINE DATE
DEPARTMENT OF TRANSPORTATION FEDERAL AVIATION ADMINISTRATION FORT LAUDERDALE AIRPORT TRAFFIC CONTROL TOWER MAJOR IMPROVEMENTS GENERAL ATCT - DRAWING INDEX		APPROVED BY	APVD
REVIEWED BY	SUBMITTED BY	DATE	JCN
DESIGNED	ISSUED BY	DATE	JCN
DRAWN	ATLANTA TERMINAL ENGINEERING CENTER	DATE	JCN
CHECKED	RAB	DRAWING NO	REV
WW JOB NUMBER: 219075.00		FLL-D-TOWB-G002	

A AMPERE  
AA AIR COOLED  
AAV AUTOMATIC AIR VENT  
ABG ABOVE FINISHED GRADE  
AC ALTERNATING CURRENT, ABOVE CEILING  
A/C AIR CONDITIONING  
ACC AIR COOLED CHILLER  
ACDFC AIR COOLED DRY FLUID COOLER  
ACI AMERICAN CONCRETE INSTITUTE  
ACM ASBESTOS CONTAINING MATERIAL  
ACT ACOUSTICAL CEILING TILE, ACCESS CONTROL TERMINAL  
AD ACCESS DOOR, AREA DRAIN  
ADJ ADJUSTABLE  
AF AMPERE FRAME  
AFF ABOVE FINISHED FLOOR  
AFG ABOVE FINISHED GRADE  
AFR ABOVE FINISHED ROOF  
AH AIR HANDLER  
AHU AIR HANDLING UNIT  
AI ANALOG INPUT  
AIC AMPERE INTERRUPTING CAPACITY  
AISC AMERICAN INSTITUTE OF STEEL CONSTRUCTION  
AL AIRPORT LIGHTING, ALUMINUM  
AL-GL ALUMINUM AND GLASS  
ALUM ALUMINUM  
AMM AMMETER  
ANN ANNUNCIATOR  
ANSI AMERICAN NATIONAL STANDARDS INSTITUTE  
AO ANALOG OUTPUT  
AP ANNUNCIATOR POINT, ACCESS PANEL  
APD AIR PRESSURE DROP  
APPROX APPROXIMATELY  
ARCH ARCHITECT, ARCHITECTURAL  
ARTS AUTOMATED RADAR  
AS AIR SEPARATOR  
A/S AUDIBLE STROBE  
ASHRAE AMERICAN SOCIETY OF HEATING, REFRIGERATION AND AIR CONDITIONING ENGINEERS  
ASME AMERICAN SOCIETY OF MECHANICAL ENGINEERS  
AT AMPERE TRIP  
ATBM AIRWAY/TERMINAL BUILDING MAINTENANCE FACILITY  
ATC ACOUSTICAL TILE CEILING  
ATC AIR TRAFFIC CONTROL  
ATCT AIRPORT TRAFFIC CONTROL TOWER  
ATS AUTOMATIC TRANSFER SWITCH  
ATV ATMOSPHERIC VENT  
AUX AUXILIARY  
AV AUTOMATIC VENT  
AVG AVERAGE  
AWG AMERICAN WIRE GAUGE  
AWS AMERICAN WELDING SOCIETY

COMMUNICATIONS  
CONC CONCRETE  
COND CONDENSATE  
CONFIG CONFIGURATION  
CONN CONNECTION  
CONT CONTINUATION  
CONTR CONTRACTOR  
COR CONTRACTING OFFICER'S REPRESENTATIVE  
CPC CRITICAL POWER CENTER  
CPT CARPET  
CPU CENTRAL PROCESSING UNIT  
CR CONTROL RELAY  
CS CONTROL SWITCH  
CSF CHEMICAL SHOT FEEDER  
CT COOLING TOWER, CABLE TRAY, CURRENT TRANSFORMER, CERAMIC TILE CONTROL  
CTL CONTROL  
CU CONDENSING UNIT, COPPER  
CU FT CUBIC FOOT/FEET  
CV CONSTANT VOLUME, CONTROL VALVE  
CVC CENTRAL VACUUM CLEANER  
CW COLD (DOMESTIC) WATER  
CWP CONDENSER WATER PUMP, CHILLED WATER PUMP  
CWR CONDENSER WATER RETURN  
CWS CONDENSER WATER SUPPLY  
CWW COMBINATION WASTE AND VENT  
CY YD CUBIC YARD

D DRAIN  
DAMP DAMPER  
DB DRY BULB, DIRECT BURIAL, DUCTBANK  
DBL DOUBLE  
DC DIRECT CURRENT  
DDC DIRECT DIGITAL CONTROL  
DEG DEGREE  
DEMO DEMOLITION  
DET DETAIL  
DG DOOR GRILLE  
DHW DOMESTIC HOT WATER  
DI DIGITAL INPUT  
DIA DIAMETER  
DIAG DIAGONAL  
DIFF DIFFUSER  
DIM DIMENSION  
DISC DISCONNECT  
DF DEGREES FAHRENHEIT  
DM DEMAND METER  
DN DOWN  
DO DIGITAL OUTPUT  
DP DIFFERENTIAL PRESSURE  
DPDT DOUBLE POLE DOUBLE THROW DISTRIBUTION PANEL  
D PNL DISTRIBUTION PANEL  
DPST DOUBLE POLE SINGLE THROW  
DPT DIFFERENTIAL PRESSURE TRANSMITTER  
DSF DESTRATIFICATION FAN  
DT DOUBLE THROW, DIAPHRAM TANK  
DTS DOUBLE THROW SWITCH  
DWBP DOMESTIC WATER BOOSTER PUMP  
DWDI DOUBLE WIDTH DOUBLE INLET  
DWGS DRAWINGS  
DWL DOWEL

E EAST  
EA EACH, EXHAUST AIR  
EAT ENTERING AIR TEMPERATURE  
ECP ENGINE CONTROL PANEL  
EDAM ELECTRICAL DATA ACQUISITION AND MONITORING  
EDH ELECTRIC DUCT HEATER  
EF EXHAUST FAN  
EG, E/G ENGINE GENERATOR, EXHAUST GRILLE EMERGENCY GENERATOR  
EH ELECTRIC HEATER, ELECTRONIC HUMIDIFIER  
EHC ELECTRIC HEATING COIL  
EIFS EXTERIOR INSULATION FINISH SYSTEM  
ELEC ELECTRIC  
ELEV, EL ELEVATION, ELEVATOR  
EMCS ENERGY MANAGEMENT AND CONTROL SYSTEM  
EMERG EMERGENCY  
EMI ELECTROMAGNETIC INTERFACE  
EMS ENERGY MANAGEMENT SYSTEM  
EMT ELECTRICAL METALLIC TUBING  
ENT ENTERING  
EQ EQUAL  
EQUIP EQUIPMENT  
ER EXHAUST REGISTER  
ERMS ENVIRONMENTAL REMOTE MONITORING SYSTEM  
ESP EXTERNAL STATIC PRESSURE  
ET EXPANSION TANK  
EUH ELECTRIC UNIT HEATER  
EW EACH WAY  
EWC ELECTRICAL WATER COOLER  
EWH ELECTRIC WALL HEATER, ELECTRIC WATER HEATER  
EWT ENTERING WATER TEMPERATURE  
EXH EXHAUST  
EXIST EXISTING  
EXP EXPOSED, EXPANSION

F FIRE WATER SUPPLY  
°F DEGREES FAHRENHEIT  
FA FIRE ALARM, FREE AREA, FAN COOLED, FRESH AIR  
FAA FEDERAL AVIATION ADMINISTRATION  
FACP FIRE ALARM CONTROL PANEL  
FACT FACTORY  
FC FACE OF CURB, FLEXIBLE CONNECTION  
FCO FLOOR CLEANOUT  
FCU FAN COIL UNIT  
FCV FLOW CONTROL VALVE  
FD FLOOR DRAIN, FIRE DAMPER  
FDC FIRE DEPARTMENT CONNECTION  
FDN FOUNDATION  
FDR FEEDER  
FE FIRE EXTINGUISHER  
FEC FIRE EXTINGUISHER CABINET  
FF FLY FAN  
FFE FINISHED FLOOR ELEVATION  
FG FIBERGLASS  
FH FIRE HYDRANT  
FHC FIRE HOSE CABINET  
FHV FIRE HOSE VALVE  
FIG FIGURE  
FIN FINISH  
FLA FULL LOAD AMPERES  
FLR FLOOR  
FLEX FLEXIBLE  
FLS FLOW SWITCH, FIRE AND LIFE SAFETY FLUORESCENT  
FLUOR FLUORESCENT  
FM FACTORY MUTUAL, FORCE MAIN  
FO FIBER OPTIC  
FOD FACE OPERATED DAMPER  
FOG FUEL OIL GAGE  
FOR FUEL OIL RETURN  
FOS FUEL OIL SUPPLY  
FOT FIBER OPTIC TERMINAL, FUEL OIL TRANSFER FIRE PUMP  
FP FIRE PUMP  
FPM FEET PER MINUTE  
FPU FIELD PROGRAMMING UNIT  
FS FLOW SWITCH, FLOOR SINK  
FSD FIRE/SMOKE DAMPER  
FSS FUSIBLE SAFETY SWITCH  
FT FEET  
FTG FOOTING, FITTING  
FV FULL VOLTAGE  
FVC FIRE VALVE CABINET  
FW FIRE WATER  
FWS FIRE WATER SUPPLY  
FWD FORWARD, FIRE SPRINKLER WATER DRAIN

G GROUND  
GA GAUGE  
GAL GALLON  
GALV GALVANIZED  
GEN GENERAL, GENERATOR  
GFCI GROUND FAULT CIRCUIT INTERRUPTER  
GFE GOVERNMENT FURNISHED EQUIPMENT  
GFM GOVERNMENT FURNISHED MATERIAL  
GND GROUND CONNECTOR  
GOVT GOVERNMENT  
GPH GALLONS PER HOUR  
GPM GALLONS PER MINUTE  
GRN GREEN  
GRS GALVANIZED RIGID STEEL  
GUH GAS FIRED UNIT HEATER  
GWB GYPSUM WALLBOARD  
GYP GYPSUM

H HAZARDOUS MATERIALS  
HB HOSE BIBB  
HEX HEXAGONAL  
HH HAND HOLE  
HM HOLLOW METAL  
H. MET. HOLLOW METAL  
HOA HAND-OFF-AUTOMATIC  
HORIZ HORIZONTAL  
HP HORSEPOWER  
HPS HIGH PRESSURE SODIUM  
HR HOUR  
HS HIGH STRENGTH  
HSB HIGH STRENGTH BOLT  
HT HEIGHT  
HTG HEATING  
HTR HEATER  
HU HUMIDIFIER  
HVAC HEATING, VENTILATION AND AIR CONDITIONING  
HWP HOT WATER PUMP  
HWR HOT WATER RETURN  
HWS HOT WATER SUPPLY  
HWH HOT WATER UNIT HEATER  
HX HEAT EXCHANGER  
HZ HERTZ

I INTERCOMMUNICATION, INTERCOM  
IE INVERT ELEVATION  
IN INCHES  
INCAND INCANDESCENT  
INCL INCLUDE  
INDIC INDICATOR  
INSUL INSULATED  
INT INTERIOR  
INV INVERT  
ISMS INTEGRATED SECURITY MANAGEMENT SYSTEM

J JUNCTION BOX  
JB Jockey Pump  
JP JOCKEY PUMP  
JT JOINT

K KILOAMPERES  
KA THOUSAND CIRCULAR MILLS  
KCMIL THOUSAND CIRCULAR MILLS  
KV KILOVOLT  
KVA KILOVOLT AMPERES  
KVAR KILOVOLT AMPERES-REACTIVE  
KW KILOWATT  
KWH KILOWATT HOUR

L LOUVER AND SCREEN  
L&S LOUVER AND SCREEN  
LAT LEAVING AIR TEMPERATURE  
LBD LINEAR BAR DIFFUSER  
LBG LINEAR BAR GRILLE  
LBR LINEAR BAR RETURN  
LBS POUNDS  
LD LINEAR DIFFUSER  
LF LINEAR FEET  
LFS LIGHTING FIXTURE SCHEDULE  
LLH LONG LEG HORIZONTAL  
LLV LONG LEG VERTICAL  
LONG LONGITUDINAL  
LOSP LOCAL OPERATING STATUS PANEL  
LP LOW POINT  
LRA LOCKED ROTOR AMPERE  
LRAG LINEAR RETURN AIR GRILLE  
LRG LINEAR RETURN GRILLE  
LS LIGHT STANDARD  
LSD LINEAR SLOT DIFFUSER  
LT LIQUID TIGHT  
LTG LIGHTING  
LV LOW VOLTAGE  
LVL LEVEL  
LWT LEAVING WATER TEMPERATURE

M MAGNETIC DOOR HOLD OPEN  
MAG MAGNETIC DOOR HOLD OPEN  
MAINT MAINTENANCE  
MAX MAXIMUM  
MBH THOUSAND BTU/HOUR  
MBP MAINTENANCE BYPASS PANEL  
MCB MOLDED CASE BREAKER  
MCC MOTOR CONTROL CENTER  
MCM THOUSAND CIRCULAR MILLS  
MCP MOTOR CIRCUIT PROTECTOR  
MD MANUAL DAMPER  
MDF MEDIUM DENSITY FIBERBOARD  
MDT MAIN DISTRIBUTION TERMINAL  
MECH MECHANICAL  
MED MEDIUM  
MEMB MEMBRANE  
MFR MANUFACTURER  
MG MOTOR GENERATOR  
MH MANHOLE  
MIL THOUSANDTHS OF AN INCH  
MIL ST MILITARY STANDARD  
MIN MINIMAL, MINUTE, MINIMUM  
MISC MISCELLANEOUS  
MLO MAIN LUGS ONLY  
MM MILLIMETER  
MOD MOTOR OPERATED DAMPER  
MPG GAS FIRED UNIT HEATER  
MTD MOUNTED  
MTL METAL  
MUA MAKE-UP AIR  
MUW MAKE-UP WATER  
MV MANUAL VENT  
MVA MEGAVOLT AMPERE  
MVD MANUAL VOLUME DAMPER

SCALES SHOWN FOR 22" X 34" SHEET. ADJUST SCALES FOR OTHER SIZES. PAGE OF

REV	APPROVED DATE	DESCRIPTION	JCN	REDLINE DATE	APVD
-----	---------------	-------------	-----	--------------	------

DEPARTMENT OF TRANSPORTATION  
FEDERAL AVIATION ADMINISTRATION

FORT LAUDERDALE AIRPORT TRAFFIC CONTROL TOWER  
MAJOR IMPROVEMENTS  
GENERAL  
ABBREVIATIONS - SHEET 1

FT LAUDERDALE (INTERNATIONAL) FL

REVIEWED BY: SUBMITTED BY: APPROVED BY:

DESIGNED: CRK ISSUED BY: DATE: JAN 31, 2020 JCN: 1508912

DRAWN: CRK ATLANTA TERMINAL ENGINEERING CENTER DRAWING NO: FLL-D-TOWB-G010 REV

CHECKED: RAB

WileyWilson  
5901 Peachtree Dunwoody Rd.  
Bldg. C, Ste 515  
Atlanta, Georgia 30328-6055  
678.320.1888  
wileywilson.com  
WW JOB NUMBER: 219075.00

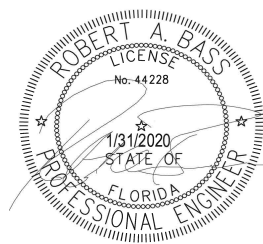

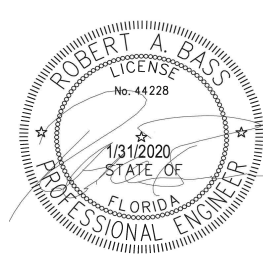

N	NORTH, NEUTRAL	RL	RAIN LEADER	U	UNIFORM BUILDING CODE
NA	NOT APPLICABLE	RM	ROOM	UBC	UNDERCUT
NC	NOISE CRITERIA	RMH	ROOF MOUNTED HOOD	UC	UNDERGROUND
N.C.	NORMALLY CLOSED	RML	RADAR MICROWAVE LINK	UG	UNDERGROUND POWER
NEC	NATIONAL ELECTRIC CODE	RMS	ROOT MEAN SQUARE	UHP	UNIT HEATER
NEG	NEGATIVE	RO	REVERSE OSMOSIS	UH	UNDERWRITER'S LABORATORY
NEMA	NATIONAL ELECTRICAL MANUFACTURERS' ASSOCIATION	RP BP	REDUCED PRESSURE BACKFLOW PREVENTER	UL	UNFUSED
NFHB	NON-FREEZE HOSE BIB	RPM	ROTATIONS PER MINUTE, REVOLUTIONS PER MINUTE	UNF	UNLESS NOTED OTHERWISE
NFPA	NATIONAL FIRE PROTECTION ASSOCIATION	RPZ	REDUCED PRESSURE ZONE	UDN	UNLESS OTHERWISE NOTED
NG	NATURAL GAS	ROMTS	REQUIREMENTS	UPC	UNIFORM PLUMBING CODE
NIC	NOT IN CONTRACT	RTN	RETURN	UPS,U	UNINTERRUPTIBLE POWER SUPPLY
NK	NECK	RTU	ROOF TOP UNIT	UTIL	UTILITY
NO	NUMBER OF DESIGNATION	RV	RELIEF VALVE		
N.O.	NORMALLY OPEN	S		V	VOLT, VOLTAGE, VENT
NOM	NOMINAL	S	SOUTH, STAIN COLOR, SANITARY	VA	VOLT AMPERE, VOICE ALARM
NTE	NOT TO EXCEED	SA	SUPPLY AIR	VAC	VACUUM
NTS	NOT TO SCALE	SAN	SANITARY	VAV	VARIABLE AIR VOLUME
		SC	SPIN IN COLLAR WITH VOLUME DAMPER, SENSIBLE COOLING	VB	VACUUM BREAKER
O	OUTSIDE AIR	S.C.	SOLID CORE	VCT	VINYL COMPOSITE TILE
OAF	OUTSIDE AIR FAN	SCC	SECURITY CONTROL CENTER	VD	VOLUME DAMPER - MANUAL
OBD	OPPOSED BLADE DAMPER	SCHD	SCHEDULE	VDT	VIDEO DISPLAY TERMINAL
OC	ON CENTER	SCHWP	SECONDARY CHILLED WATER PUMP	VENT	VENTILATION
OD	OUTSIDE DIAMETER, OVERFLOW DRAIN	SCHWR	SECONDARY CHILLED WATER RETURN	VERT	VERTICAL
ODP	OPEN DRIP PROOF	SCHWS	SECONDARY CHILLED WATER SUPPLY	VEST	VESTIBULE
OE	OPEN END	SCND	SECONDARY	VFD	VARIABLE FREQUENCY DRIVE
OH	OPPOSITE HAND, OVERHEAD	SCP	SYSTEM CONTROL PANEL, SMOKE CONTROL PANEL	VM	VOLTMETER
OPNG	OPENING	SD	SPLITTER DAMPER STORM DRAIN, SMOKE DETECTOR	VPF	VESTIBLE PRESSURIZATION FAN
OPP	OPPOSITE	S.D.	SUPPLY DIFFUSER	VTR	VENT THROUGH ROOF
ORD	OVERFLOW ROOF DRAIN	SEC	SECONDARY		
ORL	OVERFLOW ROOF LEADER	SECT	SECTION	W	WEST, WIDTH, WATT
OSA	OUTSIDE SUPPLY AIR	SENS	SENSIBLE	W	WITH
OSCO	OUTSIDE CLEANOUT	SF	SQUARE FEET	W/O	WITHOUT
OVHD	OVERHEAD	SG	SUPPLY GRILLE	WB	WET BULB
OZ	OUNCES	SGL	SINGLE	WC	WATER COLUMN, WATER CLOSET, WALL COVERING
		SHDWN	SHUT DOWN	WCO	WALL CLEANOUT
P		SHLD	SHIELDED	WG	WATER GAUGE
P	POLE, PAINT, PUMP	SHT	SHEET	WH	WATER HEATER, WALL HEATER, WALL HYDRANT
PABX	PRIVATE AUTOMATIC BRANCH EXCHANGE	SIM	SIMILAR	WHA	WATER HAMMER ARRESTER
PART	PARTITION	SMACNA	SHEET METAL AND AIR CONDITIONING CONTRACTORS' NATIONAL ASSOCIATION	WM	WATT METER
PB	PULL BOX	SOV	SHUT-OFF VALVE	WMS	WIRE MESH SCREEN
PCF	POUNDS PER CUBIC FOOT	SP	STATIC PRESSURE (IN W.G.), SINGLE POLE, SUMP PUMP	WP	SUBSCRIPT "WP" APPLIED TO ANY SYMBOL INDICATES WEATHERPROOF NEMA TYPE 3R OR EQUIVALENT, UDN
PCHWR	PRIMARY CHILLED WATER RETURN	SPEC	SPECIFICATION	WPD	WATER PRESSURE DROP
PCHWS	PRIMARY CHILLED WATER SUPPLY	SPF	STAIRWELL PRESSURIZATION FAN	WSW	WASHDOWN SUPPLY WATER
PCMS	POWER CONTROL MONITORING SYSTEM	SPST	SINGLE POLE SINGLE THROW	WT	WATER TANK
PCS	POWER CONDITIONING SYSTEM	SPT	STATIC PRESSURE TRANSMITTER	WTR	WATER
PD	PRESSURE DROP	SPVR	SUPERVISORY CONDITION	WWF	WELODED WIRE FABRIC
PF	POWER FACTOR	SQ	SQUARE		
PFD	PERFORATED FACE DIFFUSER	SQ.FT.	SQUARE FOOT/FEET	X	AUXILIARY RELAY
PFR	PERFORATED FACE RETURN	SR	SUPPLY REGISTER	X	TRANSFER
PH	ELECTRICAL PHASE	SRG	SIGNAL REFERENCE GRID	XFR	TRANSFORMER
PI	PRESSURE INDICATOR	SS	STAINLESS STEEL	XFMR	TRANSFORMER
PIU	POWER INDUCTION UNIT	S/S	START-STOP	XMTR	TRANSMITTER
PL	PLATE	ST	SHUNT TRIP	XDCR	TRANSDUCER
PLBG	PLUMBING	STD	STANDARD		
PLCS	PLACES	STGP	SIGNAL TRANSPORT GROUND PLANE	Y	WYE
PLYWD	PLYWOOD	STL	STEEL	Y-A	WYE DELTA
PM	POWER MANHOLE	STP	SHIELDED TWISTED PAIR	Z	
PMB	POWER MIXING BOX	STRUCT	STRUCTURAL	Z	IMPEDANCE
PNL	PANEL, PANELBOARD	SUBJ	SUBJUNCTION		
P.D.C.	POINT OF CONNECTION	SUSP	SUSPENDED		
POS	POSITIVE, POSITION	SW	SWITCH		
PP	POWER POLE, PATCH PANEL	SWBD	SWITCHBOARD		
PREFAB	PREFABRICATED	SWG	SIDEWALL GRILLE		
PRESS	PRESSURE	SWGR	SWITCHGEAR		
PRMY	PRIMARY	SWR	SIDEWALL REGISTER		
PRSR	PRESSURIZATION	SWS1	SINGLE WIDTH SINGLE INLET		
PROP	PROPELLER	SWSR	SIDE WALL SUPPLY REGISTER		
PRV	PRESSURE REDUCING VALVE	SYM	SYMMETRICAL		
PS	PRESSURE SWITCH	SYS	SYSTEM		
PSF	POUNDS PER SQ. FOOT	T			
PSI	POUNDS PER SQ. INCH	T	TRANSducer		
PSIA	POUNDS PER SQ. IN. ABSOLUTE	T&B	TOP AND BOTTOM		
PSIG	POUNDS PER SQ. IN. GAUGE	T&P	TEMPERATURE AND PRESSURE		
PT	PRESSURE TRANSMITTER, PRESSURE-TEMPERATURE PORT	TB	TERMINAL BOX, TERMINAL BOARD		
PTAC	PACKAGED TERMINAL AIR CONDITIONER	TC	TRIP COIL, TOTAL COOLING, TIME CLOCK		
PVC	POLYVINYL CHLORIDE, POINT OF VERTICAL CURVATURE	TD	TIME DELAY, TRENCH DRAIN		
PVMT	PAVEMENT	TEF	TOILET EXHAUST FAN		
		TEL	TELEPHONE		
Q		TELCO	TELEPHONE COMPANY		
QUA	QUARTER	TEMP	TEMPERATURE		
		TERM	TERMINAL		
R		TC	TRANSFER GRILLE		
R	RED, RISER, RADIATOR, RADIUS, REFRIGERANT	THK	THICK, THICKNESS		
RA	RETURN AIR, REMOTE ANNUNCIATOR	TOC	TOP OF CONCRETE		
RACP	REMOTE ACCESS CONTROL PANEL	TOD	TOP OF DUCT		
RAD	RADIUS	TOS,T/S	TOP OF STEEL		
RAG	RETURN AIR GRILLE	TOWB	ATCT AND ATTACHED BASE BUILDING		
RAR	RETURN AIR REGISTER	TP	TRAP PRIMER, TWISTER PAIR		
RB	RUBBER BASE	TRBL	TROUBLE CONDITION		
RCP	REINFORCED CONCRETE PIPE, REFLECTED CEILING PLAN	TRACO	TERMINAL RADAR APPROACH CONTROL BUILDING		
RD	ROOF DRAIN	TS	TWO SPEED		
RDF	RUBBER RAISED DISK FLOOR	TSP	TOTAL STATIC PRESSURE, TRAP SEAL PRIMER		
RE	RESIDENT ENGINEER	T*STAT	THERMOSTAT		
REBAR	REINFORCING STEEL BAR	TT	TEMPERATURE TRANSMITTER		
REC	RECEPTACLE	TTB	TELEPHONE TERMINAL BOARD		
REC'D	RECEIVED	TV	TELEVISION, TEMPERING VALVE		
RECP	RECEPTACLE	TVSS	TRANSIENT VOLTAGE SURGE SUPPRESSOR (GFM)		
RECT	RECTIFIER, RECEPTACLE	TYP	TYPICAL		
REF	REFERENCE	TW	TEMPERED WATER		
REG	REGISTER				
REINF	REINFORCEMENT, REINFORCED				
REQ'D	REQUIRED				
RET	RETURN				
REV	REVISION				
RF	RETURN FAN				
RFI	RADIO FREQUENCY INTERFERENCE				
RG	RETURN GRILLE				
RGS	RIGID GALVANIZED STEEL				

SCALES SHOWN FOR 22" X 34" SHEET. ADJUST SCALES FOR OTHER SIZES.		PAGE	OF		
					
REV	APPROVED DATE	DESCRIPTION	JCN	REDLINE DATE	APVD
<b>DEPARTMENT OF TRANSPORTATION FEDERAL AVIATION ADMINISTRATION</b>					
<b>FORT LAUDERDALE AIRPORT TRAFFIC CONTROL TOWER MAJOR IMPROVEMENTS GENERAL ABBREVIATIONS - SHEET 2</b>					
FT LAUDERDALE		(INTERNATIONAL)	FL		
REVIEWED BY	SUBMITTED BY	APPROVED BY			
SUBMITTER'S TITLE - CIVIL ENGINEER		APPROVER'S TITLE - MANAGER			
DESIGNED	GMR	ISSUED BY	DATE	JCN	
DRAWN	CRK	ATLANTA TERMINAL ENGINEERING CENTER	JAN 31, 2020	1508912	
CHECKED	RAB		DRAWING NO	FLL-D-TOWB-G011	
WW JOB NUMBER: 219075.00					



## DESIGN CRITERIA AND REFERENCES

- INTERNATIONAL BUILDING CODE (IBC), 2015.
- INTERNATIONAL FIRE CODE (IFC), 2015.
- INTERNATIONAL MECHANICAL CODE (IMC), 2015.
- INTERNATIONAL PLUMBING CODE (IPC), 2015.
- NATIONAL ELECTRICAL CODE (NEC), 2017.
- NATIONAL FIRE PROTECTION ASSOCIATION (NFPA) 13, STANDARD FOR THE INSTALLATION OF SPRINKLER SYSTEMS, 2016.
- NATIONAL FIRE PROTECTION ASSOCIATION (NFPA) 20, STANDARD FOR THE INSTALLATION STATIONARY PUMPS FOR FIRE PROTECTION, 2016.
- NATIONAL FIRE PROTECTION ASSOCIATION (NFPA) 70, NATIONAL ELECTRICAL CODE, 2017.
- NATIONAL FIRE PROTECTION ASSOCIATION (NFPA) 72, NATIONAL FIRE ALARM AND SIGNALING CODE, 2016.
- NATIONAL FIRE PROTECTION ASSOCIATION (NFPA) 75, STANDARD FOR THE PROTECTION OF INFORMATION TECHNOLOGY EQUIPMENT, 2013.
- NATIONAL FIRE PROTECTION ASSOCIATION (NFPA) 90A, STANDARD FOR THE INSTALLATION OF AIR-CONDITIONING AND VENTILATION SYSTEMS, 2015.
- NATIONAL FIRE PROTECTION ASSOCIATION (NFPA) 92, STANDARD FOR SMOKE CONTROL SYSTEMS, 2015.
- NATIONAL FIRE PROTECTION ASSOCIATION (NFPA) 101, LIFE SAFETY CODE, 2015
- NATIONAL FIRE PROTECTION ASSOCIATION (NFPA) 110, STANDARD FOR EMERGENCY AND STANDBY POWER SYSTEMS, 2016
- NATIONAL FIRE PROTECTION ASSOCIATION (NFPA) 780, STANDARD FOR THE INSTALLATION OF LIGHT PROTECTION SYSTEMS, 2015.
- APPLICABLE FAA ORDERS AND STANDARDS.

## CONSTRUCTION NOTES

1. ~~FAA WILL COORDINATE PHASING PLAN WITH FACILITY TO MINIMIZE THE DISRUPTION OF OPERATIONS. THE CONTRACTOR SHALL USE THIS PHASING PLAN AND PROVIDE A COMPLETE AND COMPREHENSIVE SCHEDULE TO THE CONTRACTING OFFICERS REPRESENTATIVE FOR REVIEW AND APPROVAL BEFORE A NOTICE TO PROCEED IS ISSUED. SCHEDULE SHALL OUTLINE ALL PHASES OF THE WORK AND THEIR IMPACT ON THE OPERATION OF THE FACILITY.~~
2. ~~SIGNIFICANT AMOUNTS OF WORK MUST BE COMPLETED AFTER NORMAL OPERATING HOURS.~~
3. CONSTRUCTION NOISE, DUST AND DEBRIS MUST NOT INTERFERE WITH OPERATION OF ATCT FACILITY. MAINTAIN HEPA FILTRATION OF CONSTRUCTION AREA DURING ALL GENERAL CONSTRUCTION SEQUENCES.
4. THE CONSTRUCTION OF THIS PROJECT MUST NOT INTERFERE WITH OPERATION OF THE AIR TRAFFIC CONTROL FUNCTION OR ACCESS AND EGRESS TO THE FACILITY DURING NORMAL OPERATING HOURS. ALL WORK NEEDS TO BE COORDINATED WITH FAA CONTRACTING OFFICERS REPRESENTATIVE TO AVOID DISRUPTION TO THE NORMAL OPERATIONS OF THE FACILITY. NORMAL HOURS OF OPERATION ARE STATED IN DIVISION 1 OF THE SPECIFICATIONS.
5. LOCKOUT AND TAG PROCEDURES MUST BE FOLLOWED AT ALL TIMES.
6. IF NECESSARY ALL ELECTRONIC EQUIPMENT CIRCUITS SHALL BE RELOCATED BY THE FAA. ALL OTHER BUILDING SYSTEMS CIRCUITS SHALL BE RELOCATED BY THE CONTRACTOR. COORDINATE WITH CONTRACTING OFFICERS REPRESENTATIVE.
7. CONTRACTOR SHALL USE VERY LOW VOC PAINTS AND COATINGS AND PROVIDE ADEQUATE MEASURES FOR VENTILATION TO MINIMIZE ODORS DURING PAINTING, CURING OF FRP RESINS AND OTHER CONSTRUCTION ACTIVITIES THAT HAVE THE POTENTIAL FOR STRONG ODORS. THE CONTRACTING OFFICERS REPRESENTATIVE SHALL APPROVE THE SYSTEM TO BE UTILIZED FOR VENTILATION PRIOR TO USE.
8. DO NOT PAINT OVER ANY FIRE DOOR LABEL.
9. REINSTALL ALL SMOKE/FIRE DETECTORS AS REQUIRED.
10. ALL INTERIOR DIMENSIONS ARE FROM THE FACE OF STUD OF MASONRY STRUCTURE, UNLESS OTHERWISE NOTED.
11. ALL EXTERIOR DIMENSIONS ARE FROM THE EXTERIOR FACE OF WALL.
12. MANUFACTURED ITEMS SHALL BE INSTALLED IN ACCORDANCE WITH MANUFACTURER'S INSTRUCTIONS.
13. IF AN UNSAFE CONDITION OR LIFE THREATENING HAZARD IS NOTED AT THE SITE, NOTIFY THE FAA CONTRACTING OFFICERS REPRESENTATIVE IMMEDIATELY.
14. ANY DISCREPANCIES BETWEEN THE EXISTING CONDITIONS AND THE CONTRACT DOCUMENTS, OR ANY AMBIGUITIES OR INCONSISTENCIES CONTAIN THEREIN, SHALL BE REPORTED TO THE FAA CONTRACTING OFFICERS REPRESENTATIVE (COR) IMMEDIATELY, AND SUITABLE RESOLUTION ESTABLISHED PRIOR TO THE BEGINNING OF THE AFFECTED WORK. WORK THAT PROCEEDS IN VIOLATION OF THIS PRINCIPLE IS AT THE CONTRACTOR'S OWN RISK, AND THE COST OF ANY CHANGES REQUIRED BY THE CLIENT TO SUITABLY MODIFY SUCH WORK SHALL BE SOLELY THE RESPONSIBILITY OF THE CONTRACTOR.
15. THESE DRAWINGS SHALL NOT BE SCALED FOR DIMENSIONS. IF THERE ARE DIMENSIONS DISCREPANCIES OR CONCERNS, CONTACT THE FAA COR TO CLARIFY.

## DEMOLITION NOTES

1. FACILITY TO BE PROTECTED DURING CONSTRUCTION AND FROM DAMAGE TO ANY EXISTING OR ADJACENT FINISHES, MATERIALS, FIXTURES OR BUILDING ASSEMBLIES. REPAIR ALL AREAS AFFECTED BY THE CONSTRUCTION TO MAINTAIN THEIR EXISTING APPEARANCE, UNLESS NOTED OTHERWISE.
2. STRUCTURAL INTEGRITY SHALL BE MAINTAINED FOR ALL BUILDING ELEMENTS DURING AND AFTER DEMOLITION.
3. IF A PORTION OF AN EXISTING WALL IS DEMOLISHED OR PATCHED, THE ENTIRE WALL OR CEILING SHALL BE PAINTED AFTER NEW CONSTRUCTION IS COMPLETED.

## CONSTRUCTION STAGING NOTES

THE FOLLOWING NOTES REPRESENT MANY OF THE MAJOR REQUIREMENTS STATED IN "DIVISION 1 - GENERAL REQUIREMENTS" OF THE SPECIFICATIONS. THESE NOTES PARAPHRASE OR SUPPLEMENT DIVISION 1 REQUIREMENTS AND ARE NOT INTENDED TO REPLACE DIVISION 1 REQUIREMENTS.

CONSTRUCTION ACCESS (VEHICLE, PEDESTRIAN AND DELIVERIES), CONTRACTOR'S PARKING, CONSTRUCTION OFFICES AND THE EXTENT/SIZE OF THE CONSTRUCTION STAGING AREA MUST BE COORDINATED WITH SITE PERSONNEL VIA THE FAA CONTRACTING OFFICERS REPRESENTATIVE.

### A. CONSTRUCTION ACCESS

1. DELIVERIES SHALL BE SCHEDULED 48 HOURS IN ADVANCE WITH THE FAA CONTRACTING OFFICERS REPRESENTATIVE AND AT TIMES OTHER THAN THE FAA EMPLOYEE SHIFT CHANGES TO AVOID CONGESTION.

### B. CONTRACTOR STAGING AREA AND PARKING

1. CONTRACTOR'S STAGING AND PERSONNEL PARKING IS LIMITED AND SHALL BE DETERMINED AT THE PRECONSTRUCTION CONFERENCE. CONTRACTOR SHALL PROVIDE SIGNS AS NECESSARY TO RESERVE AN AREA FOR CONSTRUCTION PARKING ONLY.

### C. FAA SECURITY REQUIREMENTS

1. AN ADVANCE LIST OF THE CONTRACTOR'S PERSONNEL SHALL BE PROVIDED TO THE FAA CONTRACTING OFFICERS REPRESENTATIVE. CONTRACTOR SUPERINTENDENT IS REQUIRED TO OBTAIN AN FAA CONTRACTOR BADGE PRIOR TO THE START OF WORK. A FACILITY ACCESS CARD WILL BE ISSUED AND WILL ALLOW ACCESS TO THE PERIMETER GATE. CONTRACTOR TO COORDINATE WITH HIS SUBS AND EMPLOYEES THE ACCESS TO THE FACILITY. TEMPORARY SECURITY BADGES MAY BE ISSUED TO THOSE CONSTRUCTION PERSONNEL. CONTRACTOR SHALL BE RESPONSIBLE FOR THE CONDUCT OF CONTRACTOR'S PERSONNEL ON SITE. CONTRACTOR VEHICLES SHALL BE IDENTIFIED AS SUCH. EACH CONSTRUCTION EMPLOYEE SHALL CHECK IN AND OUT UPON ENTERING AND LEAVING THE SITE.

2. THE BUILDING IS A SECURE AREA, AND CONSTRUCTION PERSONNEL SHALL REMAIN IN THE CONSTRUCTION AREAS. CONTRACTOR SHALL MINIMIZE INGRESS AND EGRESS.

### D. CONSTRUCTION MATERIAL STORAGE

1. STORAGE OF CONSTRUCTION MATERIALS AND TRAILERS ON THE SITE SHALL BE LIMITED TO THE CONSTRUCTION STAGING AREA. MATERIALS SHALL BE NEATLY STORED AND PROTECTED. A CONSTRUCTION FENCE SHALL BE PROVIDED AT THE DISCRETION OF THE FAA CONTRACTING OFFICERS REPRESENTATIVE. CONTRACTOR SHALL NOT PERFORM ANY DIGGING WITHOUT PERMISSION FROM THE FAA CONTRACTING OFFICERS REPRESENTATIVE. BURIED CABLES AND OTHER EXISTING UNDERGROUND UTILITIES MAY RUN THROUGH THE STAGING AREA AND ELSEWHERE.

### E. CONSTRUCTION DEBRIS

1. ENCLOSED DUMPSTERS FOR DISPOSAL OF CONSTRUCTION DEBRIS SHALL BE PROVIDED BY THE CONTRACTOR WITHIN THE STAGING AREA. THE AREAS AROUND THE DUMPSTERS SHALL BE KEPT CLEAN AND FREE OF DEBRIS AND DUST DURING CONSTRUCTION. DEBRIS SHALL BE REMOVED BY THE CONTRACTOR IN A TIMELY MANNER.
2. REMOVE ALL CONSTRUCTION AND/OR DEMOLITION DEBRIS FROM THE JOB SITE TO MAINTAIN A CLEAN AND SAFE ENVIRONMENT AND TO PREVENT THE POSSIBILITY OF A FIRE OR LIFE SAFETY HAZARD.

### F. DEMOLITION AND CONSTRUCTION HOURS

1. THE CONTRACTOR SHALL NOT INTERFERE WITH THE AIR TRAFFIC CONTROL FUNCTION OF THE FACILITY. DEMOLITION NOISE, CONSTRUCTION NOISE AND ALL WORK IN AREAS ADJACENT TO THE AIR TRAFFIC CONTROL FUNCTION MUST BE ACCOMPLISHED AFTER NORMAL OPERATING HOURS. COORDINATE NIGHT WORK AND OVERTIME CONSTRUCTION IN ADVANCE WITH THE FAA CONTRACTING OFFICERS REPRESENTATIVE.

### 2. SEE CONSTRUCTION SEQUENCE NOTES FOR FURTHER INFORMATION.

3. CONCRETE SAWING, GRINDING, CORE DRILLING, CONCRETE DEMOLITION AND ANCHOR DRILLING WILL BE ALLOWED ONLY AT PREARRANGED TIMES APPROVED BY THE FAA CONTRACTING OFFICERS REPRESENTATIVE.

### G. EQUIPMENT PROTECTION

1. EXISTING FAA AIR TRAFFIC COMPUTERS AND EQUIPMENT SHALL REMAIN OPERATIONAL THROUGHOUT THE DURATION OF THIS CONTRACT. THE CONTRACTOR SHALL BE RESPONSIBLE FOR THE CONTINUOUS PROTECTION OF THIS EQUIPMENT FROM PHYSICAL AND ELECTRICAL DAMAGE AS A RESULT OF INCIDENTAL OR ACCIDENTAL NEGLIGENCE SUCH AS, BUT NOT LIMITED TO, DISRUPTION OF POWER TO THE UNITS. INFORM THE FAA CONTRACTING OFFICERS REPRESENTATIVE IMMEDIATELY IF SUCH DAMAGE OR DISRUPTION OF POWER SHOULD OCCUR. THE LOSS OF THESE COMPUTERS AND EQUIPMENT FOR ANY AMOUNT OF TIME WILL JEOPARDIZE THE SAFETY OF THE FLYING PUBLIC. SEE SPECIAL NOTES ON SHEET M000 FOR ADDITIONAL REQUIREMENTS.
2. SHUTDOWNS, CUTOVERS AND ANY TEMPORARY PROVISIONS FOR PLUMBING, MECHANICAL AND ELECTRICAL SYSTEMS SHALL BE ACCOMPLISHED AFTER NORMAL OPERATING HOURS. PREPARATORY WORK SHALL BE COMPLETED PRIOR TO SHUTDOWN. CUTOVER WORK SHALL BE SCHEDULED AND COORDINATED WITH THE FAA CONTRACTING OFFICERS REPRESENTATIVE A MINIMUM OF 10 WORKING DAYS IN ADVANCE OF THE SHUTDOWN OR CUTOVER.
3. WELDING EQUIPMENT SHALL NOT BE POWERED BY THE FACILITY ELECTRICAL SYSTEM. WELDING SHALL NOT BE PERMITTED IN FAA OCCUPIED AREA.

SCALES SHOWN FOR 22" X 34" SHEET. ADJUST SCALES FOR OTHER SIZES.		PAGE	OF
REV	APPROVED DATE	DESCRIPTION	JCN REDLINE DATE
DEPARTMENT OF TRANSPORTATION <b>FEDERAL AVIATION ADMINISTRATION</b>			
<b>FORT LAUDERDALE AIRPORT TRAFFIC CONTROL TOWER            MAJOR IMPROVEMENTS            GENERAL            CONSTRUCTION COORDINATION NOTES</b>			
FT LAUDERDALE		(INTERNATIONAL)	FL
REVIEWED BY	SUBMITTED BY	APPROVED BY	
SUBMITTER'S TITLE - CIVIL ENGINEER		APPROVER'S TITLE - MANAGER	
DESIGNED	CRK	ISSUED BY	DATE JAN 31, 2020 JCN 1508912
DRAWN	CRK	ATLANTA TERMINAL ENGINEERING CENTER	DRAWING NO
CHECKED	RAB		FLL-D-ATCT-G040
WW JOB NUMBER: 219075.00			

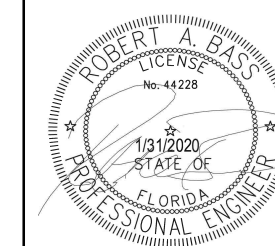

**WileyWilson**  
 5901 Peachtree Dunwoody Rd.  
 Bldg. C, Ste 515  
 Atlanta, Georgia 30328-6055  
 678.320.1888  
 wileywilson.com

SUSPECTED ASBESTOS MATERIAL LOCATION SUMMARY (SEE SPECIFICATIONS FOR ACM REPORT)				
ROOM NAME		ASBESTOS MATERIAL (ACM)	RESULTS	AFFECTED BY THE PROJECT
BASE BUILDING				
AF STORAGE, EAST WALL	6" BEIGE BASE BOARD	TAN MASTIC	TEM - SAMPLE NOT ANALYZED	NO
AF STORAGE	12"x12" PEACH VINYL FLOOR TILE	TAN MASTIC	TEM - SAMPLE NOT ANALYZED	NO
CONFERENCE ROOM	12"x12" WHITE VINYL FLOOR TILE	YELLOW MASTIC	TEM - SAMPLE NOT ANALYZED ASSUME ACM	YES
TELCO	4" BROWN VINYL BASEBOARD	TAN MASTIC	TEM - SAMPLE NOT ANALYZED	NO
EQUIPMENT ROOM	12"x12" WHITE VINYL FLOOR TILE WITH SPOTS AND BLACK MASTIC	BLACK MASTIC	YES	NO
		OFF WHITE FLOOR TILE	TEM - SAMPLE NOT ANALYZED	NO
TELCO	12"x12" WHITE VINYL FLOOR TILE WITH SPOTS AND BLACK MASTIC	BLACK MASTIC	YES	NO
ATCT				
10TH FLOOR (JUNCTION LEVEL), EQUIPM ROOM	2" BLACK VINYL BASE BOARD	YELLOW MASTIC	TEM - SAMPLE NOT ANALYZED	NO
10TH FLOOR (JUNCTION LEVEL), CORRIDOR	INTERIOR PERIMETER DRYWALL WITH JOINT COMPOUND	WHITE JOINT COMPOUND	YES	YES
	12"x12" WHITE VINYL FLOOR TILE GREY SPOTS	YELLOW MASTIC	TEM - SAMPLE NOT ANALYZED ASSUME ACM	YES
10TH FLOOR (JUNCTION LEVEL), STAIRS	BLACK VINYL FLOOR TILE WITH STRIKES AND MASTIC	YELLOW MASTIC	TEM - SAMPLE NOT ANALYZED	NO

### HAZMAT NOTES

- BUILDING CONTAINS HAZARDOUS MATERIAL (HAZMAT). THE TABLE ON THIS DRAWING IS A SUMMARY OF ASBESTOS CONTAINING MATERIAL (ACM) AND IT'S LOCATION AS SHOWN IN THE REPORT PREPARED BY RESEARCH MANAGEMENT CONSULTANTS, INC. A SUMMARY OF THIS REPORT IS INCLUDED AS AN APPENDIX TO THE SPECIFICATIONS. THE COMPLETE REPORT IS ON FILE WITH THE FAA. PROVIDE TEST WHERE ASSUMED ACM IS LISTED.
- IT IS THE INTENT OF THIS DRAWING FOR ALL EXISTING ACM TO BE REMOVED. REFER TO APPROPRIATE SECTIONS OF FAA STANDARD SPECIFICATIONS.
- PAINTED AREAS SUCH AS THE STAIR HANDRAILS ARE ASSUMED TO CONTAIN LEAD-BASED PAINT. REFER TO FAA STANDARD SPECIFICATIONS.
- THE CONTRACTOR SHALL ENSURE THAT ALL DEMOLITION GENERATED SOLID WASTES, INCLUDING THOSE THAT CONSIST OF ASBESTOS, LEAD, OR OTHER HAZARDOUS CONSTITUENTS, WASTES, SUBSTANCES, OR MATERIALS, ARE MANAGED TO AVOID CONTAMINATION OF ENVIRONMENTAL MEDIA AND HANDLED AND DISPOSED OF CONSISTENT WITH ALL APPLICABLE LAWS AND REQUIREMENTS.

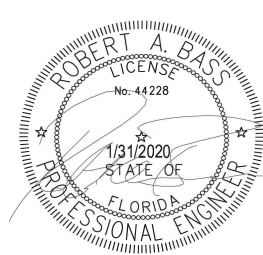
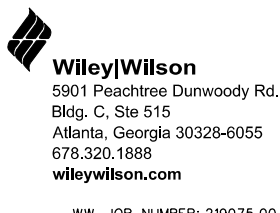
SCALES SHOWN FOR 22" X 34" SHEET. ADJUST SCALES FOR OTHER SIZES.				PAGE	OF
				REV	APPROVED DATE
				DESCRIPTION	JCN
DEPARTMENT OF TRANSPORTATION FEDERAL AVIATION ADMINISTRATION  FORT LAUDERDALE AIRPORT TRAFFIC CONTROL TOWER MAJOR IMPROVEMENTS GENERAL HAZARDOUS MATERIALS  FT LAUDERDALE (INTERNATIONAL) FL				REDLINE DATE	APVD
REVIEWED BY	SUBMITTED BY	APPROVED BY			
SUBMITTER'S TITLE - CIVIL ENGINEER		APPROVER'S TITLE - MANAGER			
DESIGNED	GMR	ISSUED BY	DATE	JCN	REV
DRAWN	GMR	ATLANTA TERMINAL ENGINEERING CENTER	JAN 31, 2020	1508912	
CHECKED	RAB	DRAWING NO. FLL-D-TOWB-H001			



**NOTES**

- ① REPLACE EXISTING 4" SANITARY SEWER FOR ENTIRE LENGTH OF RUN TO 8" LINE. APPROXIMATE LOCATION OF EXISTING 8" PIPE IS SHOWN FROM PLANS DATED 08/04/1987. SEE ATCT-D400 FOR CONTINUATION.
- ② THIS CONCRETE PATH IS MAIN EGRESS TO BUILDING. ANY WORK ON THIS AREA MUST BE PERFORMED WHEN TOWER IS UNOCCUPIED. COORDINATE WORK WITH COTR.

**When is this area unoccupied?**  
**Metal Planking Acceptable?**

**GENERAL NOTES**

- A. SEE TRACO-P000 FOR GENERAL NOTES AND SYMBOLS. SEE TOWB-G010 AND TOWB-G011 FOR ABBREVIATIONS.
- B. PIPE SHOWN ALSO SERVES EXISTING RESTROOM AT TOP OF ATCT. DEMOLITION WORK SHALL NOT COMMENCE UNTIL NEW PIPE HAS BEEN INSTALLED.

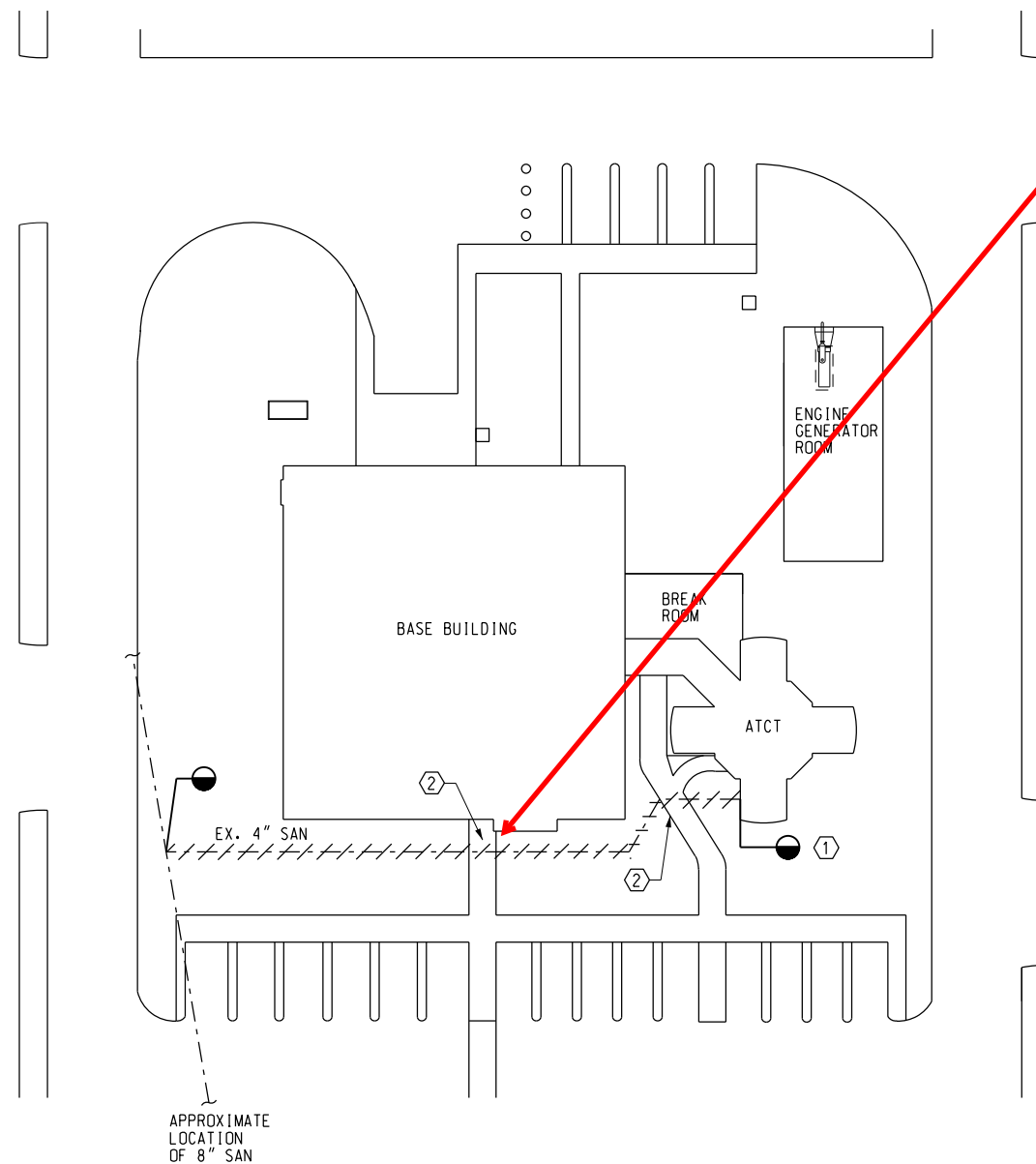

① **PLUMBING SITE PLAN - DEMOLITION**  
 D000 SCALE: 1" = 20'-0"

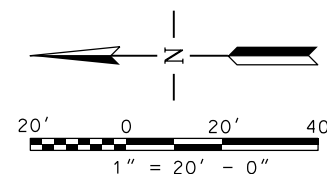

SCALES SHOWN FOR 22" X 34" SHEET. ADJUST SCALES FOR OTHER SIZES.		PAGE	OF
 <b>WileyWilson</b> 5901 Peachtree Dunwoody Rd. Bldg. C, Ste 515 Atlanta, Georgia 30328-6055 678.320.1888 wileywilson.com WW JOB NUMBER: 219075.00		DEPARTMENT OF TRANSPORTATION <b>FEDERAL AVIATION ADMINISTRATION</b>  FORT LAUDERDALE AIRPORT TRAFFIC CONTROL TOWER MAJOR IMPROVEMENTS PLUMBING SITE PLAN - DEMOLITION FT LAUDERDALE (INTERNATIONAL) FL	REV    APPROVED DATE    DESCRIPTION    JCN    REDLINE DATE    APVD
REVIEWED BY	SUBMITTED BY	APPROVED BY	
DESIGNED	JJS	SUBMITTER'S TITLE - CIVIL ENGINEER	
DRAWN	CRK	ISSUED BY	
CHECKED	JJS	ATLANTA TERMINAL ENGINEERING CENTER	
		DATE	JCN
		JAN 31, 2020	1508912
		DRAWING NO	FLL-D-TRACO-D000

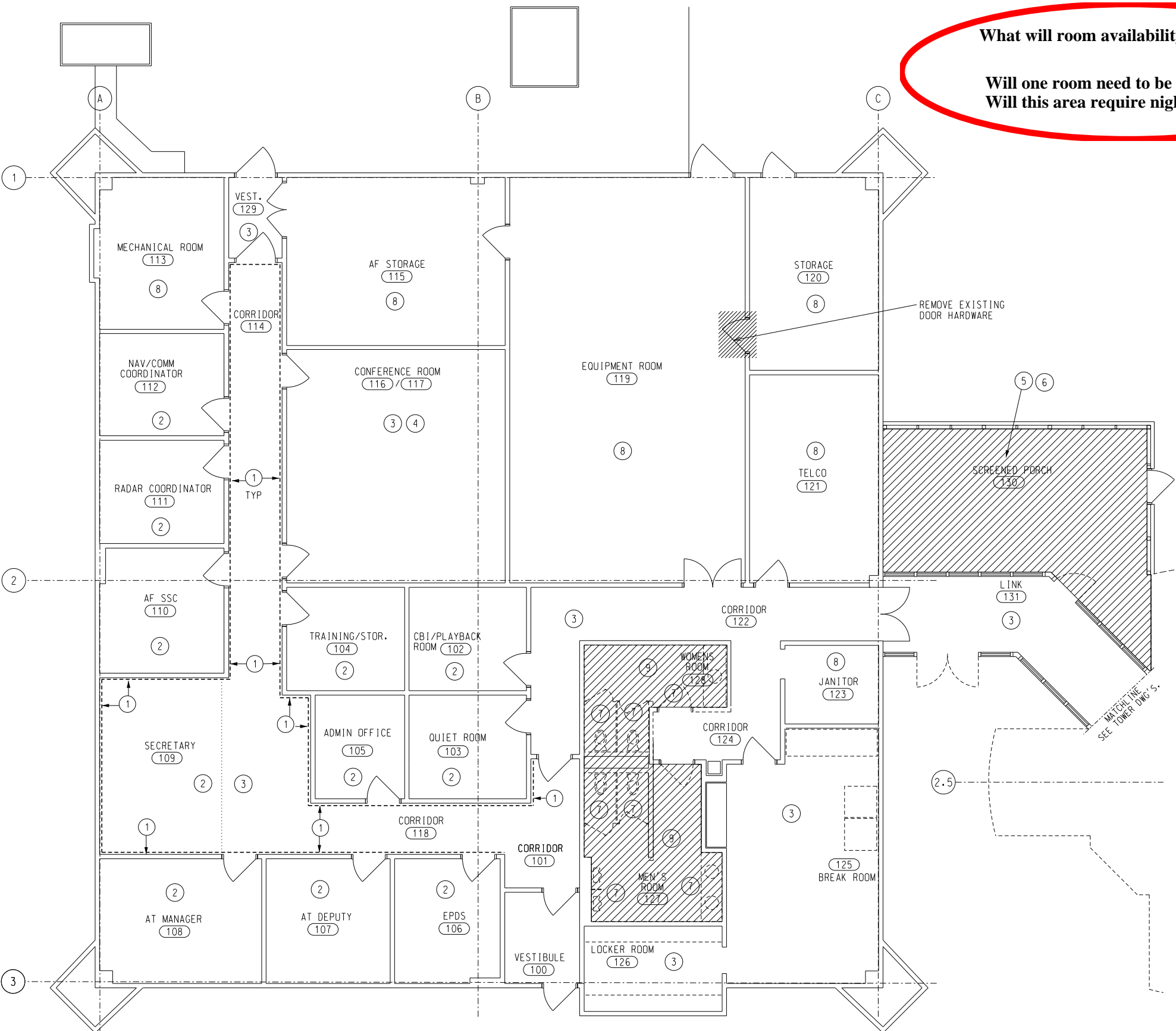

**What will room availability look like?**  
**Will one room need to be completed at a time?**  
**Will this area require night work?**

- ### KEYNOTES
- ① REMOVE EXISTING WALL COVERING. REFER TO A550 FOR NEW WALL FINISH TO BE APPLIED.
  - ② REMOVE EXISTING CARPET TILE.
  - ③ REMOVE EXISTING VCT.
  - ④ REFER TO H001 FOR HAZMAT NOTES AND REPORT INFORMATION PRIOR TO ANY DEMOLITION IN THE BUILDING.
  - ⑤ REMOVE AND SALVAGE EXISTING CEILING FIXTURES. STORE TO BE REINSTALLED. SEE D500 FOR ELECTRICAL DEMOLITION.
  - ⑥ REMOVE EXISTING SCREENED-IN PORCH CEILING AND ANY OTHER WOOD FINISHES PRESENT IN THE STRUCTURE.
  - ⑦ RESTROOMS TO BE RENOVATED. REMOVE EXISTING TOILET FIXTURES AND ACCESSORIES. CERAMIC TILES.
  - ⑧ NO WORK TO BE DONE IN THIS ROOM.
  - ⑨ REMOVE EXISTING CEILING AND CEILING FIXTURES. SEE D500 FOR ELECTRICAL DEMOLITION.
  - ⑩ REMOVE 3" ROOF/STORM DRAIN PIPE. SEE DRAWING TRACO-D140 FOR ROOF DRAIN LOCATION AND TRACO-D400 FOR PLUMBING DEMOLITION.
  - ⑪ REMOVE AND REINSTALL CEILING TILE AND GRID FOR HVAC DEMOLITION AND UPGRADES. SEE D300 FOR MECHANICAL DEMOLITION.

1 BASE BUILDING FLOOR PLAN DEMOLITION  
 D100 SCALE: 3/16" = 1' - 0"

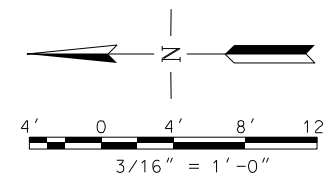

SCALES SHOWN FOR 22" X 34" SHEET. ADJUST SCALES FOR OTHER SIZES. PAGE OF

REV	APPROVED DATE	DESCRIPTION	JCN	REDLINE DATE	APVD

**WileyWilson**  
 5901 Peachtree Dunwoody Rd.  
 Bldg. C, Ste 515  
 Atlanta, Georgia 30328-6055  
 678.320.1888  
 wileywilson.com  
 WW JOB NUMBER: 219075.00

DEPARTMENT OF TRANSPORTATION FEDERAL AVIATION ADMINISTRATION					
FORT LAUDERDALE AIRPORT TRAFFIC CONTROL TOWER MAJOR IMPROVEMENTS ARCHITECTURE BASE BUILDING FLOOR PLAN DEMOLITION					
FT LAUDERDALE		(INTERNATIONAL)		FL	
REVIEWED BY	SUBMITTED BY	APPROVED BY			
DESIGNED	GMR	SUBMITTER'S TITLE - CIVIL ENGINEER	APPROVER'S TITLE - MANAGER		
DRAWN	GMR	ISSUED BY	DATE	JCN	
CHECKED	NXE	ATLANTA TERMINAL ENGINEERING CENTER	JAN 31, 2020	1508912	
				DRAWING NO	FLL-D-TRACO-D100

NOTES

1. REFER TO ELECTRICAL DEMOLITION FOR LIGHTNING PROTECTION REMOVAL.

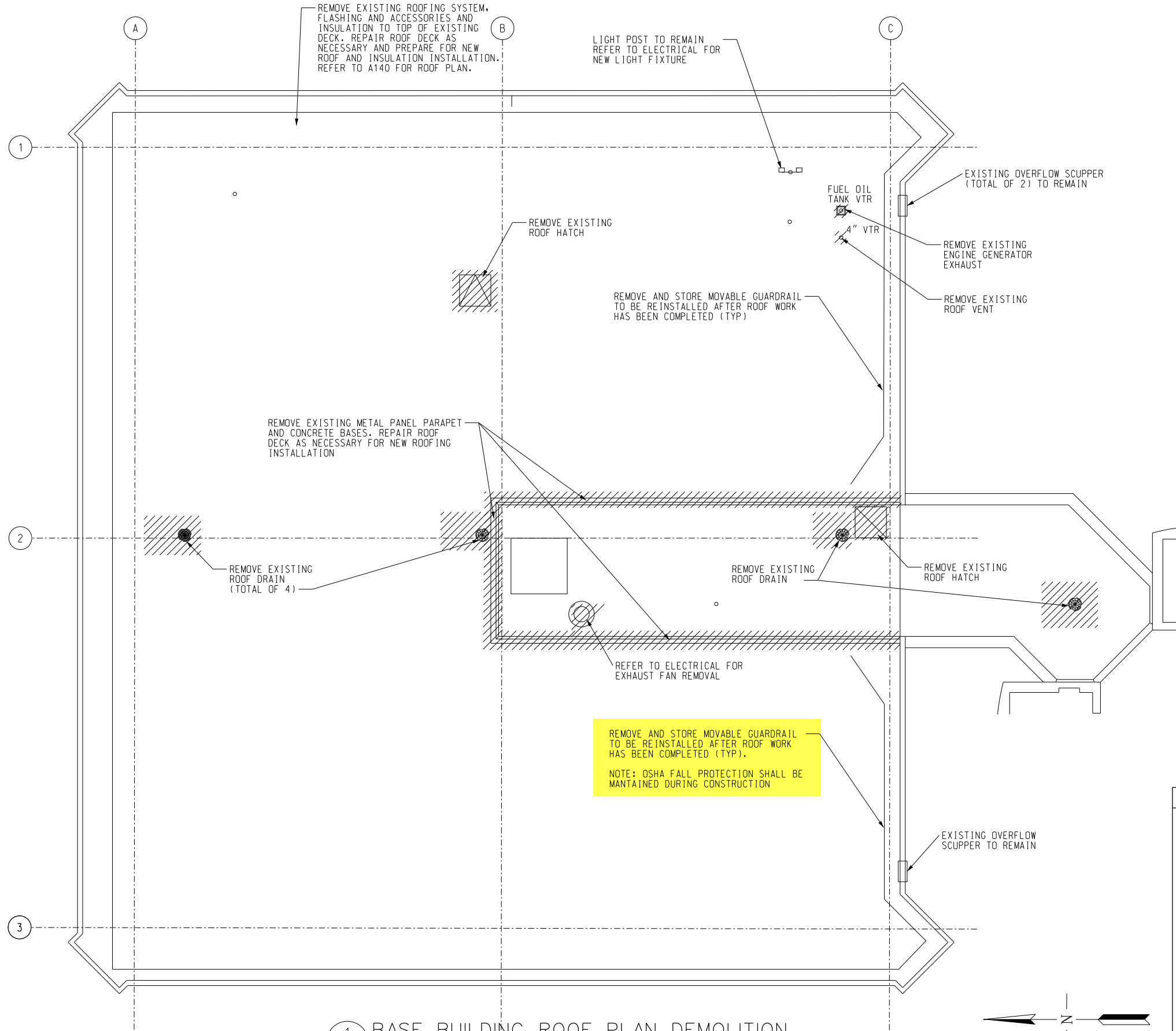

1 BASE BUILDING ROOF PLAN DEMOLITION  
D140 SCALE: 3/16" = 1' - 0"

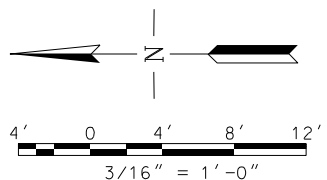

SCALES SHOWN FOR 22" X 34" SHEET. ADJUST SCALES FOR OTHER SIZES.		PAGE	OF
REV	APPROVED DATE	DESCRIPTION	JCN REDLINE DATE APVD
DEPARTMENT OF TRANSPORTATION FEDERAL AVIATION ADMINISTRATION			
FORT LAUDERDALE AIRPORT TRAFFIC CONTROL TOWER MAJOR IMPROVEMENTS ARCHITECTURE BASE BUILDING ROOF PLAN DEMOLITION			
FT LAUDERDALE		(INTERNATIONAL)	FL
REVIEWED BY	SUBMITTED BY	APPROVED BY	
SUBMITTER'S TITLE - CIVIL ENGINEER		APPROVER'S TITLE - MANAGER	
DESIGNED	GMR	ISSUED BY	DATE JAN 31, 2020 JCN 1508912
DRAWN	GMR	ATLANTA TERMINAL ENGINEERING CENTER	DRAWING NO
CHECKED	NXE		FLL-D-TRACO-D140
WW JOB NUMBER: 219075.00			



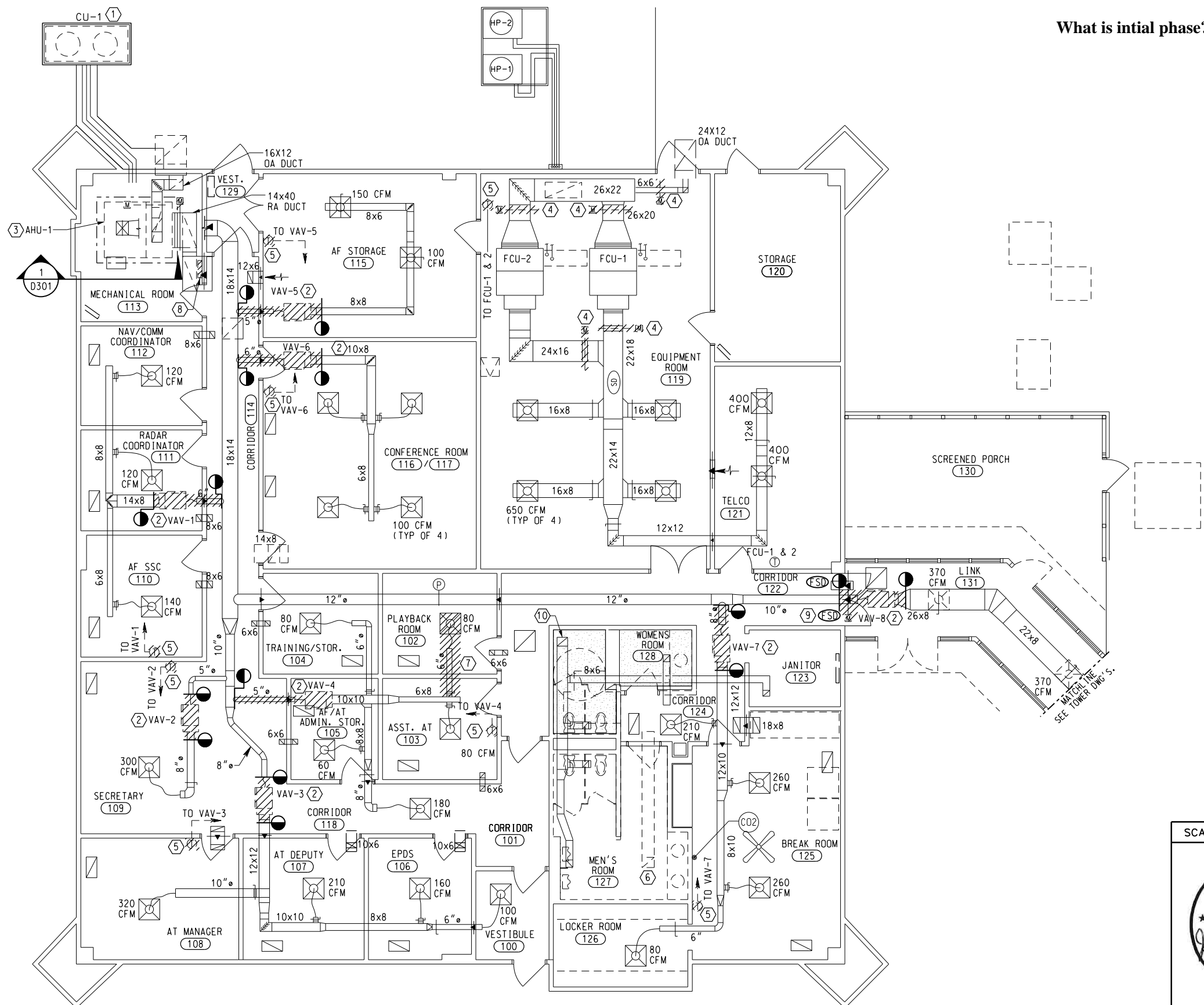

What is initial phase?

NOTES

- ① CONDENSING UNIT (CU-1) AND ASSOCIATED LINESET REPLACED IN INITIAL PHASE OF RENOVATION.
- ② REMOVE VAV BOXES (VAV-1 THRU VAV-8) AND FD WHERE APPLICABLE.
- ③ AIR HANDLING UNIT AHU-1 REPLACED IN INITIAL PHASE OF RENOVATION.
- ④ REMOVE EXISTING CONTROL DAMPERS AND ACTUATORS.
- ⑤ REMOVE EXISTING THERMOSTAT.
- ⑥ EXISTING MAKE-UP AIR DUCT FOR TOILETS.
- ⑦ REMOVE TAP AND MVD. PATCH AND SEAL DUCTWORK AIRTIGHT.
- ⑧ REMOVE EXISTING DDC CONTROL PANEL.
- ⑨ REMOVE EXISTING FIRE-SMOKE DAMPER (TYP 2).
- ⑩ UP TO EXISTING EF-2, EF-2 TO BE REMOVED.

GENERAL NOTES

- A. AIR FLOW SHOWN ON EXISTING SUPPLY AIR OUTLETS ARE FROM AS-BUILT DRAWINGS. THE APPROVED TAB CONTRACTOR SHALL PERFORM AIR FLOW TEST AND RECORD THE ACTUAL AIR FLOW ON EXISTING AIR OUTLETS IN BASE BUILDING, PRIOR TO CONSTRUCTION START OR ANY HVAC DEMOLITION WORK. RESULTS SHALL BE RETAINED AND USED TO RESTORE THE SYSTEM AT THE COMPLETION OF THE MECHANICAL WORK. THE ACTUAL AIR FLOW SHALL BE SUBMITTED TO THE FAA CONTRACTING OFFICER REPRESENTATIVE FOR REVIEW, AFTER CONSTRUCTION. THE SYSTEM SHALL BE REBALANCED ALL EXISTING AND NEW AIR DEVICES TO AIR FLOW INDICATED.
- B. EXISTING WORK SHOWN LIGHT SOLID LINE WITHOUT HATCHING SHALL REMAIN.
- C. CONTRACTOR SHALL COMPLETELY REMOVE THE EXISTING HVAC CONTROL SYSTEM INCLUDING OPERATOR WORKSTATION, CONTROL PANELS, CONTROL WIRING, THERMOSTATS AND ALL ASSOCIATED CONTROL COMPONENTS.
- D. CONTRACTOR SHALL REVIEW THE EXISTING CONTROL DRAWINGS AND ACTUAL CONTROL INSTALLATION PRIOR TO PERFORMING ANY WORK AND SHALL MINIMIZE DOWNTIME OF THE HVAC SYSTEM.
- E. SEE DRAWING TRACO-M000 FOR HVAC LEGEND, GENERAL NOTES AND SPECIAL NOTES.
- F. WHERE FIRE OR FIRE/SMOKE DAMPERS ARE REMOVED IN CONJUNCTION WITH THIS WORK, THE REMOVED DAMPER SHALL BE REPLACED WITH THE SAME TYPE, RATING AND SHALL BE COORDINATED WITH THE FIRE ALARM AND ELECTRICAL CONTRACTORS.
- G. OWNER SHALL HAVE FIRST RIGHT TO ALL EQUIPMENT THAT IS REMOVED.

① BASE BUILDING HVAC FLOOR PLAN - DEMOLITION  
D300 SCALE: 3/16" = 1' - 0"

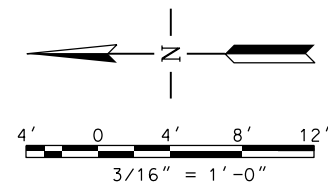

SCALES SHOWN FOR 22" X 34" SHEET. ADJUST SCALES FOR OTHER SIZES. PAGE OF

REV	APPROVED DATE	DESCRIPTION	JCN	REDLINE DATE	APVD
DEPARTMENT OF TRANSPORTATION <b>FEDERAL AVIATION ADMINISTRATION</b>  <b>FORT LAUDERDALE AIRPORT TRAFFIC CONTROL TOWER</b> <b>MAJOR IMPROVEMENTS</b> <b>MECHANICAL</b> <b>BASE BUILDING FLOOR PLAN - DEMOLITION</b>  FT LAUDERDALE (INTERNATIONAL) FL					
REVIEWED BY		SUBMITTED BY		APPROVED BY	
SUBMITTER'S TITLE - CIVIL ENGINEER		APPROVER'S TITLE - MANAGER			
DESIGNED	JJS	ISSUED BY	DATE	JCN	1508912
DRAWN	CRK	ATLANTA TERMINAL ENGINEERING CENTER	DRAWING NO	FLL-D-TRACO-D300	
CHECKED	JJS				

**WileyWilson**  
5901 Peachtree Dunwoody Rd.  
Bldg. C, Ste 515  
Atlanta, Georgia 30328-6055  
678.320.1888  
wileywilson.com  
WW JOB NUMBER: 219075.00

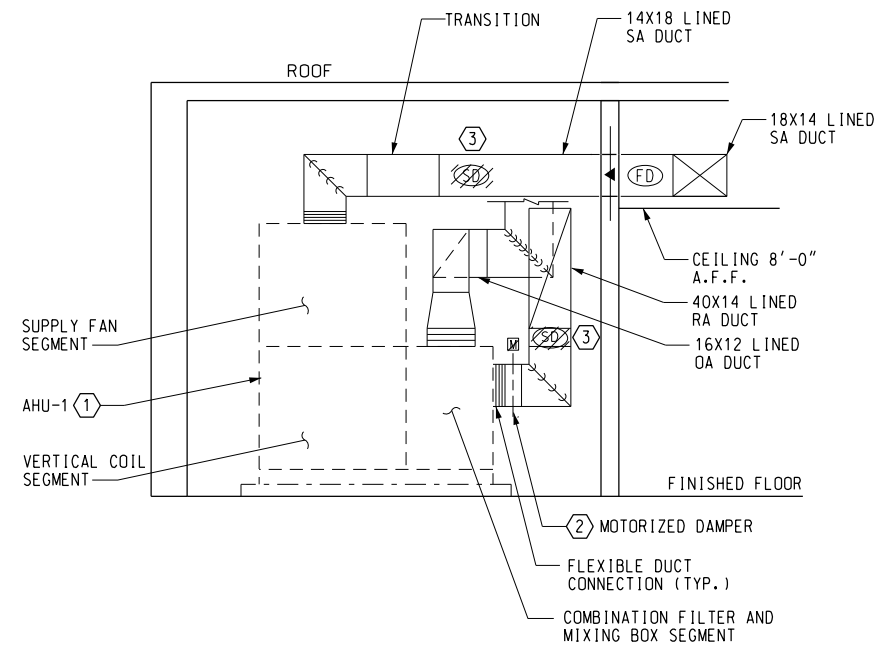

**NOTES**

- ① EXISTING AHU-1 REPLACED IN INITIAL PHASE OF RENOVATION.
- ② EXISTING MOTORIZED DAMPER TO REMAIN.
- ③ REMOVE EXISTING SMOKE DETECTORS.

**1 MECHANICAL ROOM BASE BUILDING PLAN - DEMOLITION**  
 D301 SCALE: 3/8" = 1'-0"

SCALES SHOWN FOR 22" X 34" SHEET. ADJUST SCALES FOR OTHER SIZES.				PAGE	OF
					
<b>DEPARTMENT OF TRANSPORTATION          FEDERAL AVIATION ADMINISTRATION</b>					
<b>FORT LAUDERDALE AIRPORT TRAFFIC CONTROL TOWER          MAJOR IMPROVEMENTS          MECHANICAL          MECHANICAL ROOM BASE BUILDING PLAN - DEMOLITION</b>					
FT LAUDERDALE (INTERNATIONAL) FL					
	REVIEWED BY	SUBMITTED BY	APPROVED BY		
			SUBMITTER'S TITLE - CIVIL ENGINEER		APPROVER'S TITLE - MANAGER
		DESIGNED JJS	ISSUED BY		DATE JAN 31, 2020 JCN 1508912
		DRAWN CRK	ATLANTA TERMINAL ENGINEERING CENTER		DRAWING NO
		CHECKED JJS			FLL-D-TRACO-D301 REV
WW JOB NUMBER: 219075.00					

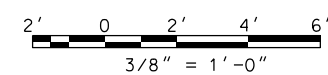

**NOTES**

- ① REMOVE EXISTING ROOF DRAINS AND REPLACE WITH 4" ROOF DRAINS. SEE TRACO-P100 FOR MORE INFORMATION. CEILING TILES WILL NEED TO BE REMOVED AND REPLACED FOR WORK.

**GENERAL NOTES**

- A. SEE DRAWING TRACO-P000 FOR PLUMBING GENERAL NOTES AND SYMBOLS. SEE TOWB-G010 AND TOWB-G011 FOR ABBREVIATIONS.
- B. CONTRACTOR SHALL NOTIFY ENGINEER IN WRITING IF SITE CONDITIONS DEVIATE SIGNIFICANTLY FROM CONTRACT DOCUMENTS.
- C. ALL WORK IN THIS AREA SHALL BE COMPLETED AFTER HOURS. ALL PHASED WORK NEEDS TO BE COMPLETED AND BUILDING PUT BACK TO WORKING ORDER BY START OF ATCT OPERATIONS.

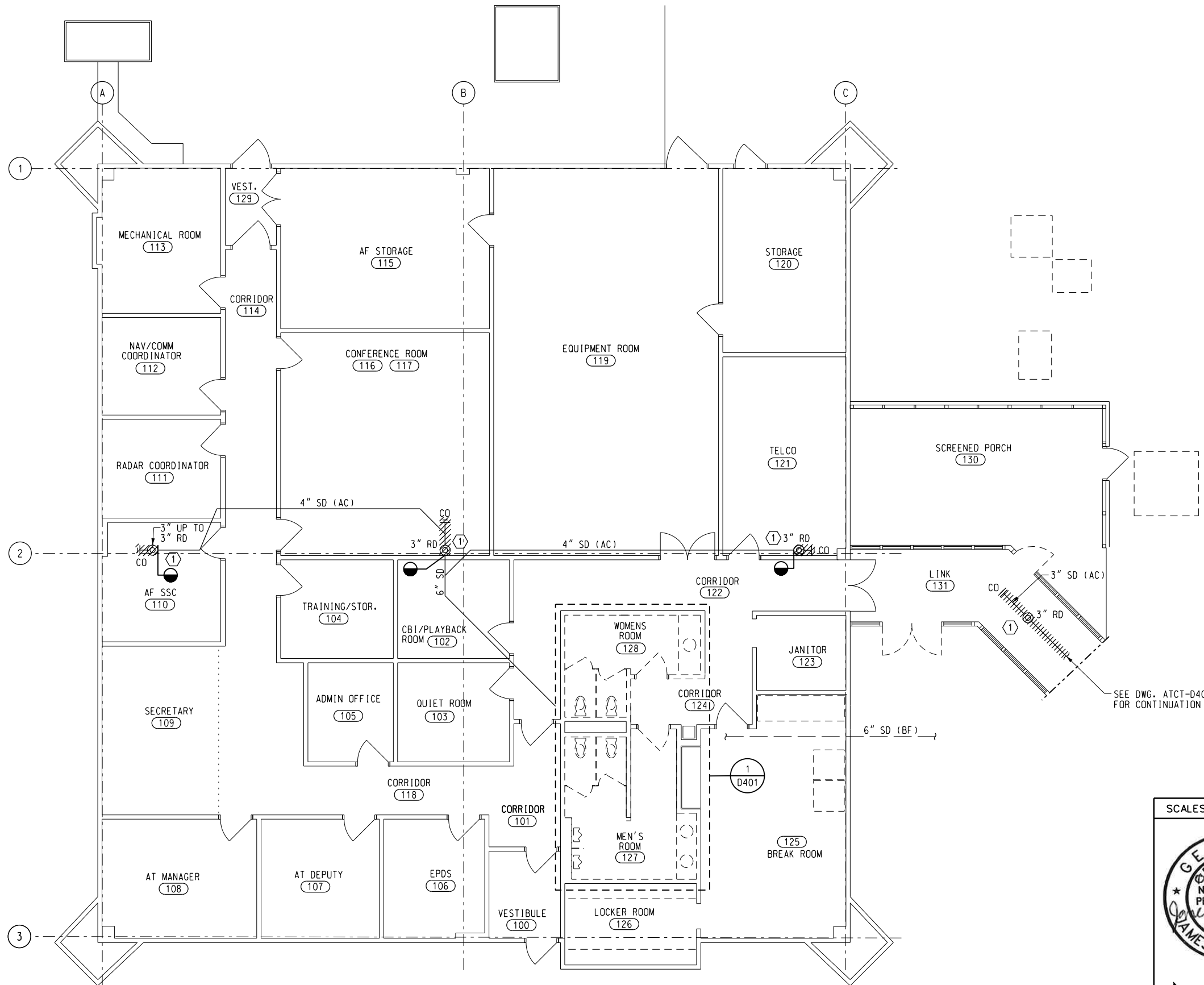

① **BASE BUILDING FLOOR PLAN - DEMOLITION**  
D400 SCALE: 3/16" = 1' - 0"

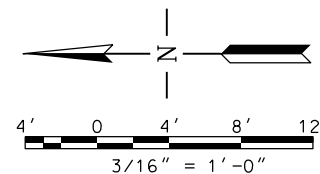

SCALES SHOWN FOR 22" X 34" SHEET. ADJUST SCALES FOR OTHER SIZES. PAGE OF



**WileyWilson**  
5901 Peachtree Dunwoody Rd.  
Bldg. C, Ste 515  
Atlanta, Georgia 30328-6055  
678.320.1888  
wileywilson.com  
WW JOB NUMBER: 219075.00

REV	APPROVED DATE	DESCRIPTION	JCN	REDLINE DATE	APVD
DEPARTMENT OF TRANSPORTATION <b>FEDERAL AVIATION ADMINISTRATION</b>  FORT LAUDERDALE AIRPORT TRAFFIC CONTROL TOWER MAJOR IMPROVEMENTS PLUMBING <b>BASE BUILDING FLOOR PLAN - DEMOLITION</b> FT LAUDERDALE (INTERNATIONAL) FL					
		REVIEWED BY	SUBMITTED BY	APPROVED BY	
		DESIGNED	ISSUED BY	APPROVER'S TITLE - MANAGER	
		DRAWN	ATLANTA TERMINAL ENGINEERING CENTER	DATE JAN 31, 2020	JCN 1508912
		CHECKED		DRAWING NO	FLL-D-TRACO-D400

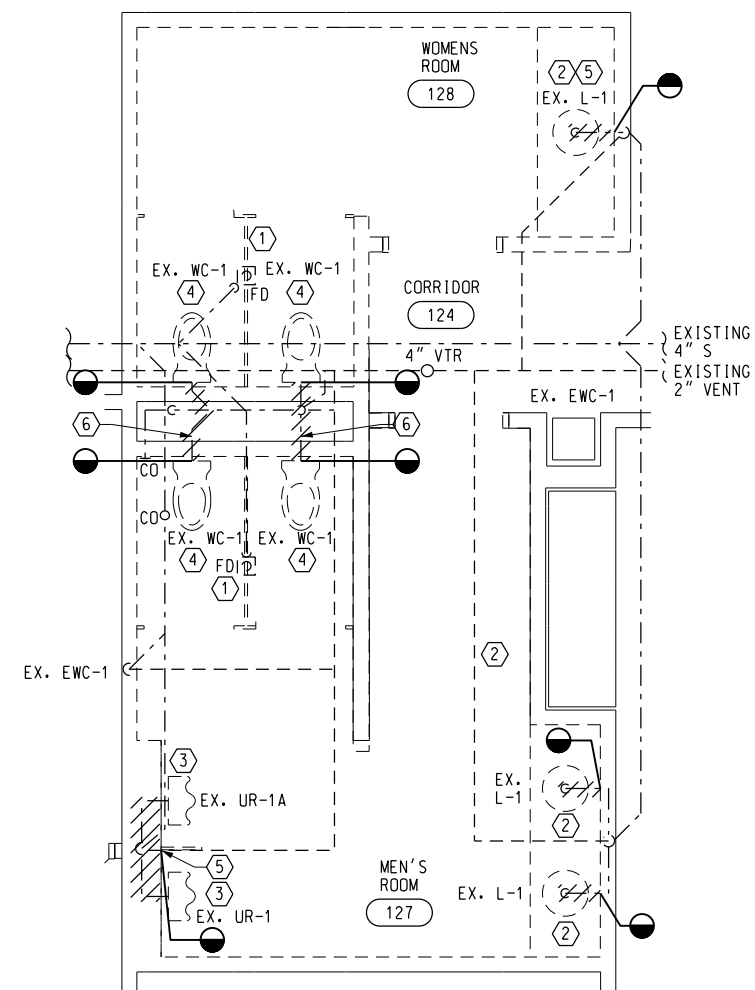

**1** ENLARGED RESTROOM  
SANITARY DEMOLITION PLAN  
D401 SCALE: 3/8" = 1' - 0"

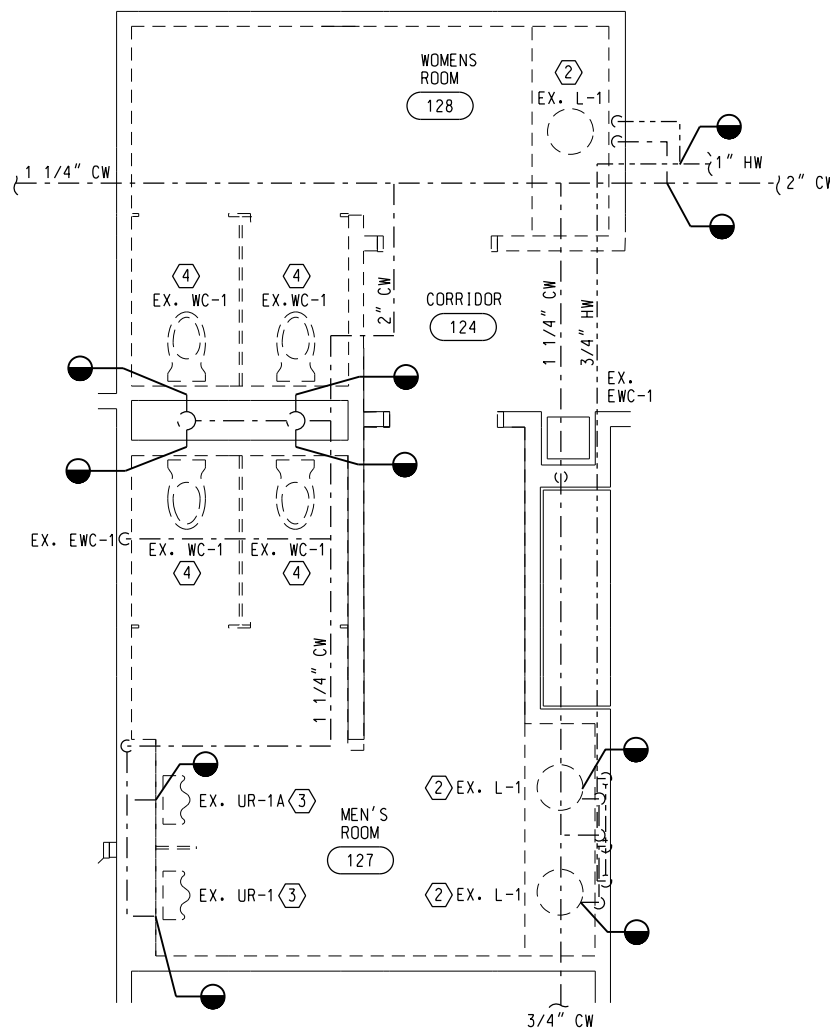

**2** ENLARGED RESTROOM  
DOMESTIC DEMOLITION PLAN  
D401 SCALE: 3/8" = 1' - 0"

**NOTES**

- ① REMOVE EXISTING FLOOR DRAIN AND ALL ASSOCIATED ACCESSORIES. REPLACE FLOOR DRAIN IN IT'S ENTIRETY WITH THE EXCEPTION OF THE P-TRAP.
- ② REMOVE EXISTING LAVATORY SUPPLY LINES, AND ALL ASSOCIATED ACCESSORIES.
- ③ REMOVE EXISTING LAVATORY URINAL FLUSH VALVES, SUPPORTS, AND ALL ASSOCIATED ACCESSORIES.
- ④ REMOVE EXISTING WATER CLOSET, FLUSH VALVE, SUPPORTS AND ALL ASSOCIATED ACCESSORIES.
- ⑤ FINISH IN THIS AREA TO BE DEMOLISHED.
- ⑥ REMOVE BACK-TO-BACK WATER CLOSET CARRIER.

**GENERAL NOTES**

- A. EXISTING WORK SHOWN LIGHT SOLID LINE WITHOUT HATCHING SHALL REMAIN.
- B. SEE TRACO-P000 FOR GENERAL NOTES AND SYMBOLS. SEE TOWB-G010 AND TOWB-G011 FOR ABBREVIATIONS.

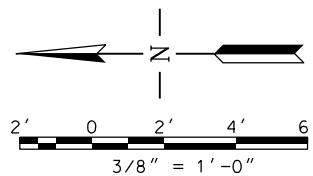

SCALES SHOWN FOR 22" X 34" SHEET. ADJUST SCALES FOR OTHER SIZES.		PAGE	OF
REV	APPROVED DATE	DESCRIPTION	JCN REDLINE DATE
DEPARTMENT OF TRANSPORTATION <b>FEDERAL AVIATION ADMINISTRATION</b>  <b>FORT LAUDERDALE AIRPORT TRAFFIC CONTROL TOWER</b> <b>MAJOR IMPROVEMENTS</b> <b>PLUMBING</b> <b>ENLARGED RESTROOM DEMOLITION PLAN</b> FT LAUDERDALE (INTERNATIONAL) FL			
REVIEWED BY	SUBMITTED BY	APPROVED BY	
DESIGNED	JJS	SUBMITTER'S TITLE - CIVIL ENGINEER	APPROVER'S TITLE - MANAGER
DRAWN	CRK	ISSUED BY	DATE JAN 31, 2020 JCN 1508912
CHECKED	JJS	ATLANTA TERMINAL ENGINEERING CENTER	DRAWING NO. FLL-D-TRACO-D401
WileyWilson 5901 Peachtree Dunwoody Rd. Bldg. C, Ste 515 Atlanta, Georgia 30328-6055 678.320.1888 wileywilson.com WW JOB NUMBER: 219075.00			

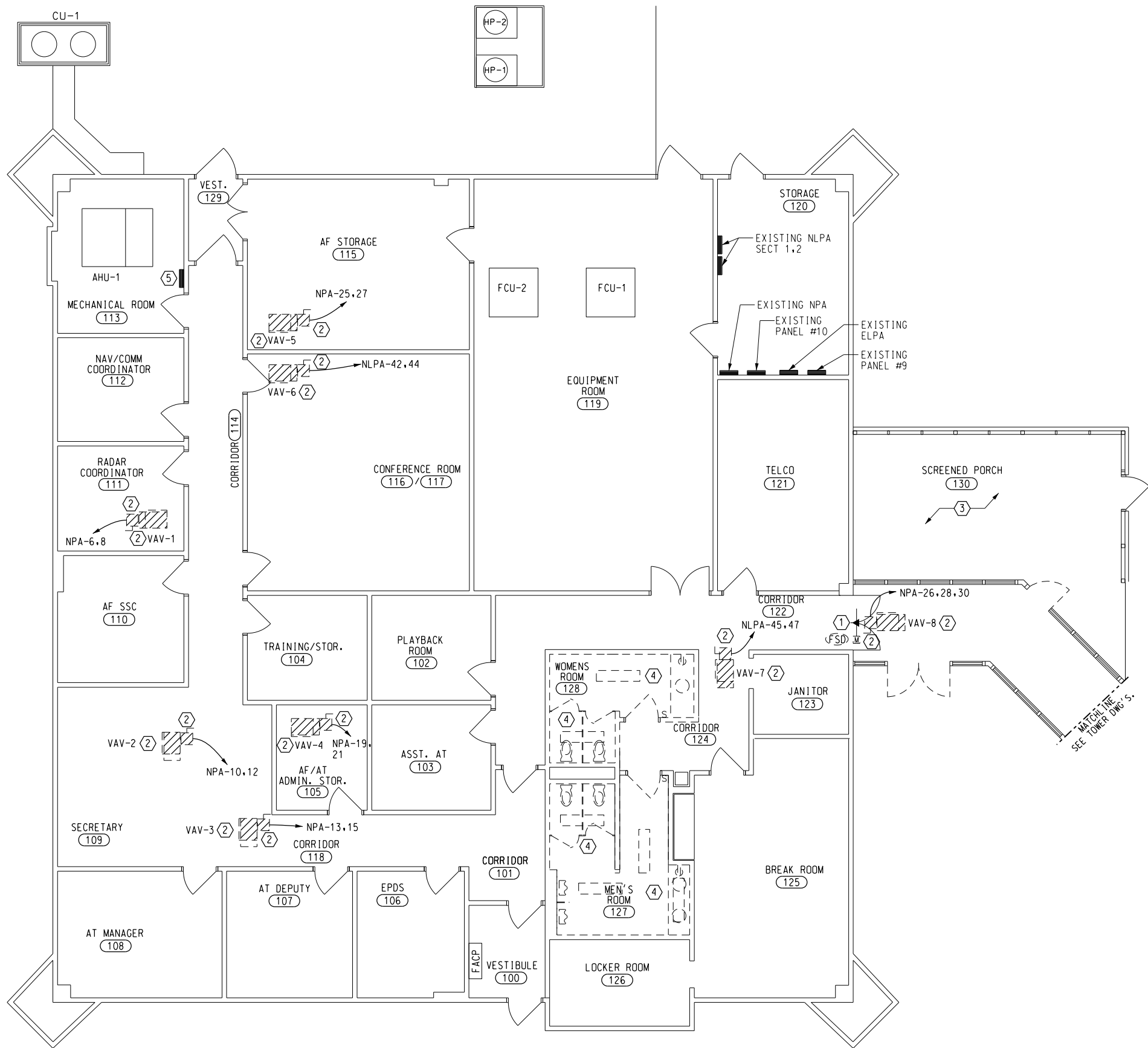

**GENERAL NOTES**

- A. EXISTING WORK SHOWN LIGHT SOLID LINE WITHOUT HATCHING SHALL REMAIN.
- B. SEE DRAWING TRACO-E000 AND TRACO-E001 FOR ELECTRICAL LEGEND, GENERAL NOTES AND SPECIAL NOTES.
- C. SEE DRAWING TRACO-D501 FOR ELECTRICAL DEMOLITION REQUIRED ON THE ROOF. REMOVE ALL ELECTRICAL CONDUCTORS AND CONDUIT BACK TO PANEL.
- D. ALL CIRCUIT NUMBERS ARE BASED ON AS-BUILT DRAWINGS. CONTRACTOR SHALL FIELD VERIFY ALL EXISTING CIRCUITS PRIOR TO DEMOLITION.

**KEY NOTES**

- ① DISCONNECT CIRCUIT WIRING TO FIRE SMOKE DAMPERS 1 & 2. DAMPER SERVED BY PANEL #9 TO BE REPLACED. WIRING TO REMAIN. COORDINATE WITH MECHANICAL.
- ② EXISTING MECHANICAL EQUIPMENT TO BE REPLACED. REMOVE DISCONNECT SWITCH AND REMOVE CONDUCTORS BACK TO PANEL. CONDUIT PATHWAY TO REMAIN FOR REUSE.
- ③ REMOVE AND SALVAGE EXISTING CEILING FANS AND LIGHT FIXTURES. CONTRACTOR SHALL DOCUMENT EXISTING CONDITIONS AND REINSTALL IN SAME CONDITIONS. ANY DAMAGE WHILE IN STORAGE OR DURING REINSTALLATION SHALL BE CORRECTED BY THE CONTRACTOR AT NO ADDITIONAL COST.
- ④ RESTROOM TO BE RENOVATED. REMOVE ALL EXISTING LIGHT FIXTURES AND ELECTRICAL DEVICES WITHIN SPACE. CIRCUITS SERVED BY PANEL NLPA SHALL REMAIN FOR CONNECTION OF NEW DEVICES.
- ⑤ EXISTING DDC CONTROL PANEL TO BE REPLACED. COORDINATE WITH MECHANICAL. REMOVE CIRCUIT BACK TO SOURCE.

**1 BASE BUILDING FLOOR PLAN - DEMOLITION**  
 D500 SCALE: 3/16" = 1' - 0"

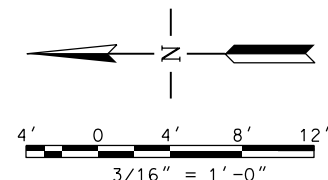

SCALES SHOWN FOR 22" X 34" SHEET. ADJUST SCALES FOR OTHER SIZES.		PAGE	OF
		REV	APPROVED DATE
<b>DEPARTMENT OF TRANSPORTATION          FEDERAL AVIATION ADMINISTRATION</b>		DESCRIPTION	JCN
<b>FORT LAUDERDALE AIRPORT TRAFFIC CONTROL TOWER          MAJOR IMPROVEMENTS          ELECTRICAL          BASE BUILDING FLOOR PLAN - DEMOLITION</b>		REVISION DATE	APVD
FT LAUDERDALE (INTERNATIONAL) FL		<b>APPROVED BY</b>	
REVIEWED BY	SUBMITTED BY	APPROVER'S TITLE - MANAGER	
SUBMITTER'S TITLE - CIVIL ENGINEER		DATE	JCN
DESIGNED	JMC	JAN 31, 2020	1508912
DRAWN	CRK	DRAWING NO	
CHECKED	MAK	<b>FLL-D-TRACO-D500</b>	
<b>WileyWilson</b> 5901 Peachtree Dunwoody Rd. Bldg. C, Ste 515 Atlanta, Georgia 30328-6055 678.320.1888 wileywilson.com WW JOB NUMBER: 219075.00			

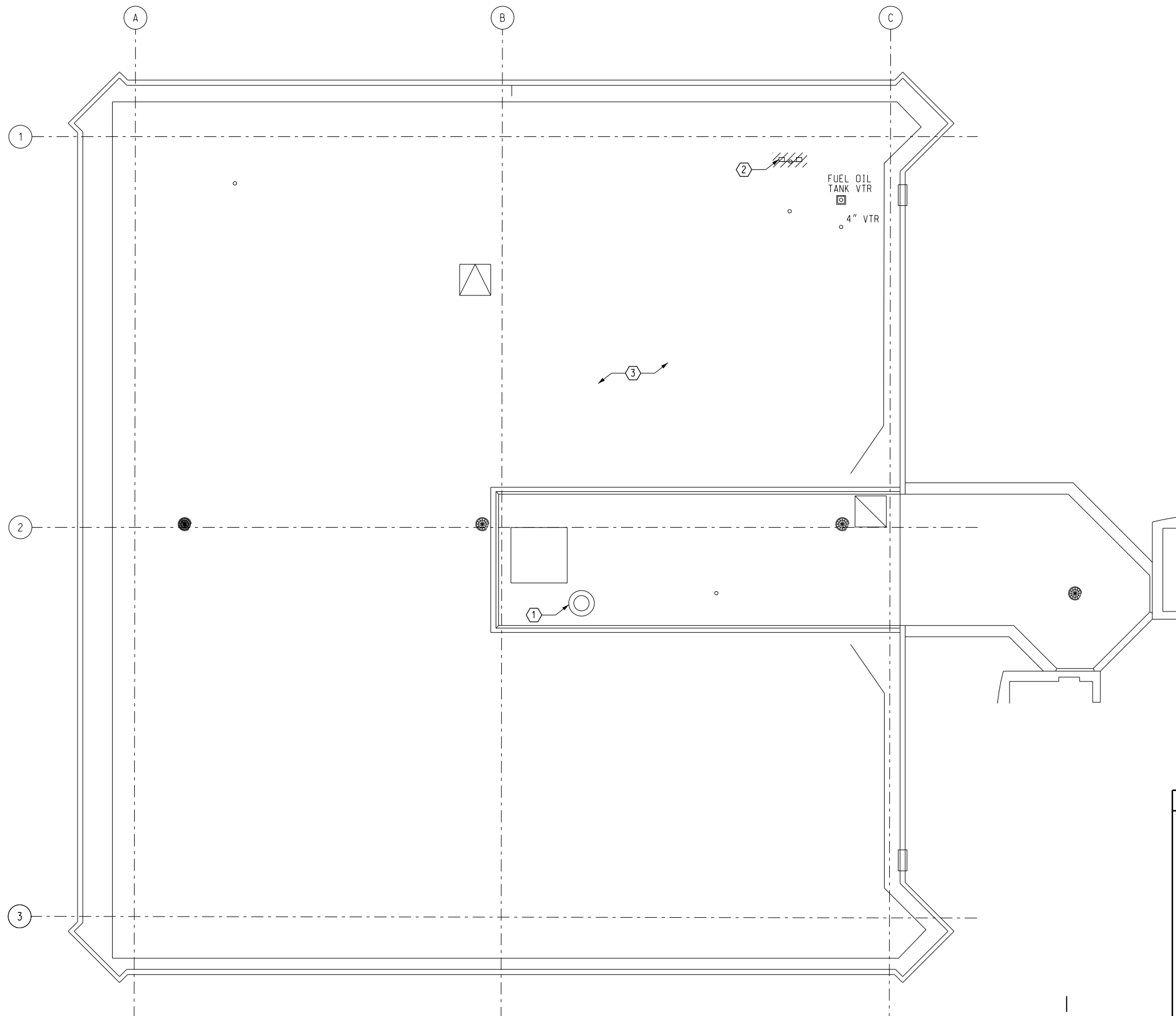

**GENERAL NOTES**

- A. EXISTING WORK SHOWN LIGHT SOLID LINE WITHOUT HATCHING SHALL REMAIN.
- B. SEE DRAWING TRACO-E000 AND TRACO-E001 FOR ELECTRICAL LEGEND, GENERAL NOTES AND SPECIAL NOTES.
- C. SEE DRAWING TRACO-D500 FOR ELECTRICAL DEMOLITION REQUIRED ON THE GROUND FLOOR. REMOVE ALL ELECTRICAL CONDUCTORS AND CONDUIT BACK TO PANEL.
- D. ALL CIRCUIT NUMBERS ARE BASED ON AS-BUILT DRAWINGS. CONTRACTOR SHALL FIELD VERIFY ALL EXISTING CIRCUITS PRIOR TO DEMOLITION.

**KEY NOTES**

- ① EXISTING EXHAUST FAN EF-2 TO BE REPLACED. EXISTING CIRCUIT AND CONDUIT SERVED FROM PANEL NPA SHALL REMAIN FOR CONNECTION OF NEW EXHAUST FAN
- ② EXISTING LIGHT FIXTURES TO BE REPLACED. EXISTING LIGHTING CIRCUIT AND CONDUIT SERVED FROM PANEL NLPA SHALL REMAIN FOR CONNECTION OF NEW FIXTURES
- ③ ENTIRE LIGHTNING PROTECTION SYSTEM CONDUCTORS AND HARDWARE TO BE REPLACED. REFER TO NEW WORK SHEET E-160 FOR MORE INFORMATION.

① **BASE BUILDING ROOF PLAN DEMOLITION**  
 D501 SCALE: 3/16" = 1' - 0"

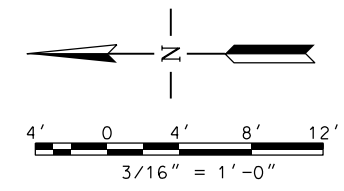

SCALES SHOWN FOR 22" X 34" SHEET. ADJUST SCALES FOR OTHER SIZES.				PAGE	OF
 <b>WileyWilson</b> 5901 Peachtree Dunwoody Rd. Bldg. C, Ste 515 Atlanta, Georgia 30328-6055 678.320.1888 wileywilson.com WW JOB NUMBER: 219075.00	DEPARTMENT OF TRANSPORTATION <b>FEDERAL AVIATION ADMINISTRATION</b>  FORT LAUDERDALE AIRPORT TRAFFIC CONTROL TOWER MAJOR IMPROVEMENTS ELECTRICAL <b>BASE BUILDING ROOF PLAN DEMOLITION</b>  FT LAUDERDALE (INTERNATIONAL) FL		REV APPROVED DATE DESCRIPTION JCN REDLINE DATE APVD	SUBMITTED BY APPROVED BY SUBMITTER'S TITLE - CIVIL ENGINEER APPROVER'S TITLE - MANAGER DATE JAN 31, 2020 JCN 1508912 DRAWING NO. FLL-D-TRACO- D501	

	DOOR NUMBER		2' X 4' LAY-IN ACOUSTICAL CEILING
	GYPSUM BOARD PARTITION		2' X 2' LAY-IN ACOUSTICAL CEILING
	PRECAST CONCRETE		SUSPENDED GYPSUM BOARD CEILING
	WINDOW NUMBER		SUPPLY DIFFUSER
			RETURN GRILLE
	TYPICAL PARTITION TYPE		EXHAUST GRILLE
	LOUVER NUMBER		
8'-6" AFF	CEILING HEIGHT DESIGNATION		
	FLOOR HATCH		
	STEEL LADDER		2' X 4' RECESSED FLUORESCENT LIGHTING FIXTURE
	SUMP		2' X 2' RECESSED FLUORESCENT LIGHTING FIXTURE
	FLOOR MOUNTED SERVICE SINK		4' FLUORESCENT LIGHTING FIXTURE, SURFACE MOUNTED
	WALL MOUNTED SERVICE SINK		2' FLUORESCENT LIGHTING FIXTURE, SURFACE MOUNTED
			4' FLUORESCENT STRIP FIXTURE
	LAVATORY IN COUNTERTOP		RECESSED FLUORESCENT/INCANDESCENT LIGHTING FIXTURE
	LAVATORY WALL MOUNTED		RECESSED FLUORESCENT, WALL WASHER LIGHTING FIXTURE
	URINAL		WALL-MOUNTED LIGHT FIXTURE
			EXIT SIGN
	WATER CLOSET FLOOR MOUNTED		BLACKENED DOT INDICATES FIXTURE WITH EMERGENCY BATTERY PACK
	WATER CLOSET WALL MOUNTED		ROOM NUMBER TAG
	ELECTRIC WATER COOLER WALL RECESSED		
	ELECTRIC WATER COOLER WALL HUNG (HANDICAP)		
	LOCKERS		
	HANDICAP DOOR OPERATOR		

SCALES SHOWN FOR 22" X 34" SHEET. ADJUST SCALES FOR OTHER SIZES. PAGE OF

REV	APPROVED DATE	DESCRIPTION	JCN	REDLINE DATE	APVD
DEPARTMENT OF TRANSPORTATION FEDERAL AVIATION ADMINISTRATION  FORT LAUDERDALE AIRPORT TRAFFIC CONTROL TOWER MAJOR IMPROVEMENTS ARCHITECTURAL LEGEND, SYMBOLS AND GENERAL NOTES  FT LAUDERDALE (INTERNATIONAL) FL					
REVIEWED BY		SUBMITTED BY		APPROVED BY	
DESIGNED		ISSUED BY		DATE	
DRAWN		ATLANTA TERMINAL ENGINEERING CENTER		JAN 31, 2020	
CHECKED		ATLANTA TERMINAL ENGINEERING CENTER		JCN 1508912	
				DRAWING NO	
				FLL-D-TRACO-A000	
				REV	

**WileyWilson**  
 5901 Peachtree Dunwoody Rd.  
 Bldg. C, Ste 515  
 Atlanta, Georgia 30328-6055  
 678.320.1888  
 wileywilson.com  
 WW JOB NUMBER: 219075.00

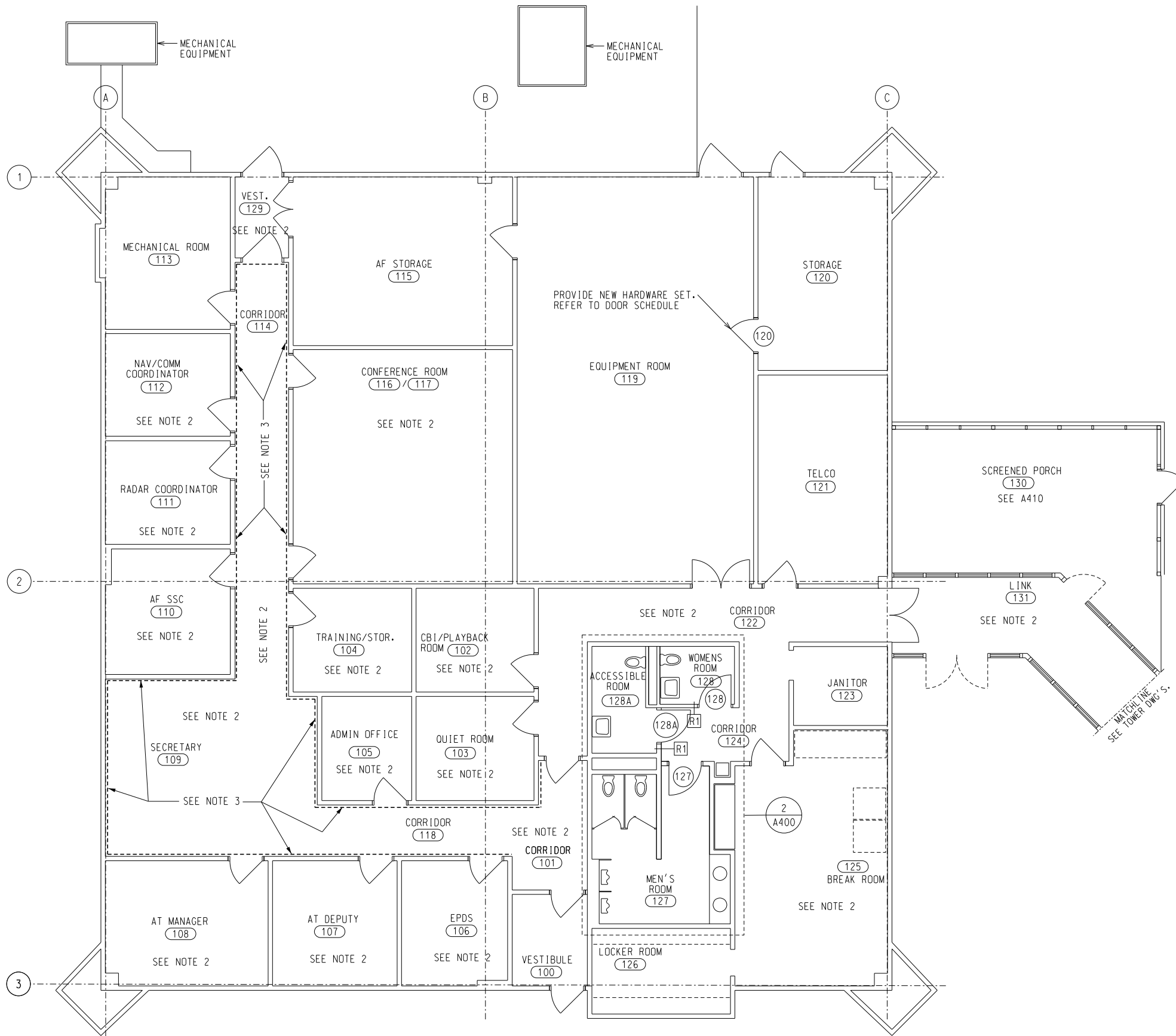

NOTES

1. REFER TO A500 FOR FINISH AND COLOR SELECTIONS.
2. FURNISH AND INSTALL NEW FLOOR FINISHES. SEE NOTE 1.
3. AFTER WALL PAPER REMOVAL, REFINISH AND PAINT WALLS OF CORRIDOR 101, 109, 114 AND 118. SEE NOTE 1.
4. REFER TO A505 FOR DOOR SCHEDULE AND WALL TYPE.

1 BASE BUILDING FLOOR PLAN  
A100 SCALE: 3/16" = 1' - 0"

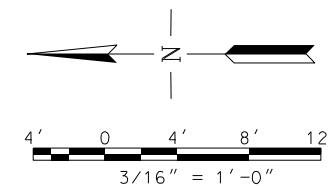

SCALES SHOWN FOR 22" X 34" SHEET. ADJUST SCALES FOR OTHER SIZES.					PAGE	OF
					REV	APPROVED DATE
<b>DEPARTMENT OF TRANSPORTATION FEDERAL AVIATION ADMINISTRATION</b>					JCN	REDLINE DATE
<b>FORT LAUDERDALE AIRPORT TRAFFIC CONTROL TOWER MAJOR IMPROVEMENTS ARCHITECTURE BASE BUILDING FLOOR PLAN</b>					APVD	
FT LAUDERDALE (INTERNATIONAL) FL						
REVIEWED BY		SUBMITTED BY		APPROVED BY		
DESIGNED		SUBMITTER'S TITLE - CIVIL ENGINEER		APPROVER'S TITLE - MANAGER		
DRAWN		ISSUED BY		DATE JAN 31, 2020 JCN 1508912		
CHECKED		ATLANTA TERMINAL ENGINEERING CENTER		DRAWING NO		
				FLL-D-TRACO-A100		
WILEY WILSON 5901 Peachtree Dunwoody Rd. Bldg. C, Ste 515 Atlanta, Georgia 30328-6055 678.320.1888 wileywilson.com WW JOB NUMBER: 219075.00						



NOTES

1. REFER TO ELECTRICAL DRAWINGS FOR NEW LIGHTNING PROTECTION.
2. ALL SLOPES TO SLOPE TO DRAIN OR MIN. 1/4". TYP.

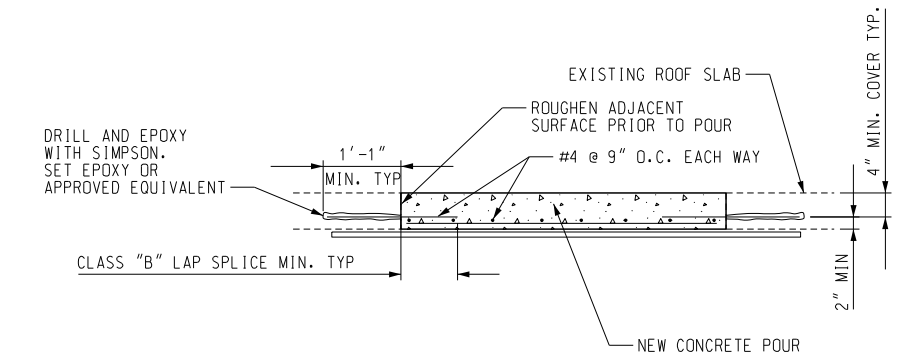
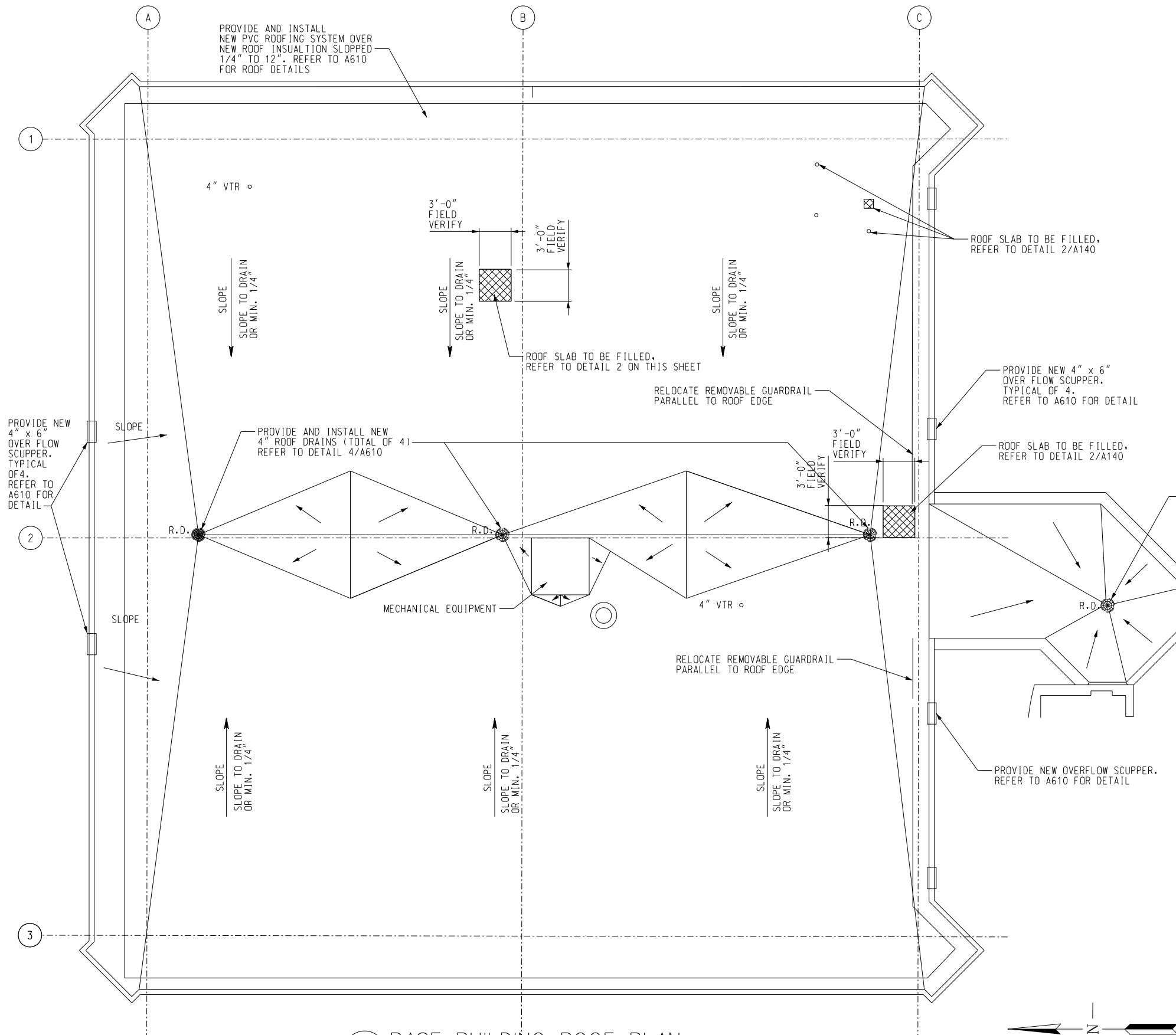

2 ROOF IN-FILL DETAIL  
A140 SCALE: 3/4" = 1' - 0"

NOTE:  
DETAIL APPLIES TO ALL ROOF PENETRATIONS TO BE CLOSED.

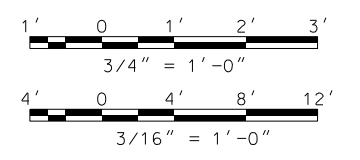

1 BASE BUILDING ROOF PLAN  
A140 SCALE: 3/16" = 1' - 0"

SCALES SHOWN FOR 22" X 34" SHEET. ADJUST SCALES FOR OTHER SIZES. PAGE OF

**WileyWilson**  
5901 Peachtree Dunwoody Rd.  
Bldg. C, Ste 515  
Atlanta, Georgia 30328-6055  
678.320.1888  
wileywilson.com  
WW JOB NUMBER: 219075.00

REV	APPROVED DATE	DESCRIPTION	JCN	REDLINE DATE	APVD

**DEPARTMENT OF TRANSPORTATION  
FEDERAL AVIATION ADMINISTRATION**

**FORT LAUDERDALE AIRPORT TRAFFIC CONTROL TOWER  
MAJOR IMPROVEMENTS  
ARCHITECTURE  
BASE BUILDING ROOF PLAN**

FT LAUDERDALE (INTERNATIONAL) FL

REVIEWED BY	SUBMITTED BY	APPROVED BY
DESIGNED	SUBMITTER'S TITLE - CIVIL ENGINEER	APPROVER'S TITLE - MANAGER
DRAWN	ISSUED BY	DATE JAN 31, 2020 JCN 1508912
CHECKED	ATLANTA TERMINAL ENGINEERING CENTER	DRAWING NO. FLL-D-TRACO-A140

NOTES

1. PROVIDE NEW BATHROOM FIXTURES. REFER TO PLUMBING DRAWINGS.
2. PROVIDE NEW ACCESSORIES, REFER TO TOILET ACCESSORIES SCHEDULE.
3. PROVIDE NEW FLOOR AND WALL CERAMIC TILE. REFER TO FINISH SCHEDULE.
4. PROVIDE NEW DOOR. REFER TO DOOR SCHEDULE.
5. PROVIDE NEW GYPSUM BOARD CEILING AND CEILING FIXTURES IN ROOMS 128 AND 128A.
6. PROVIDE NEW TOILET PARTITIONS. REFER TO A500 FOR MORE INFORMATION.
7. EXISTING CEILING TO REMAIN. EXISTING LIGHT FIXTURES TO BE REMOVED. PATCH AND PAINT CEILING. INSTALL NEW LIGHT FIXTURES. REFER TO ELECTRICAL.

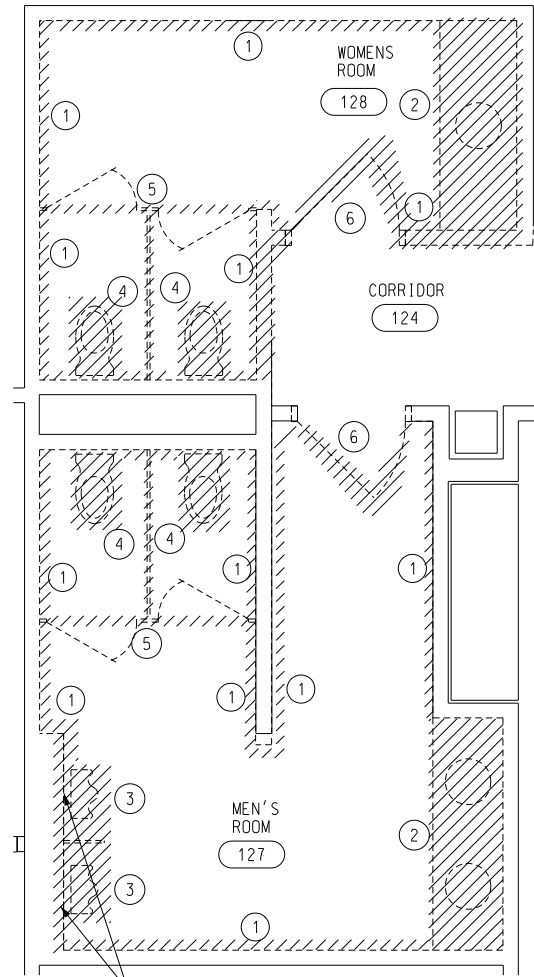

1 RESTROOM DEMO PLAN  
A400 SCALE: 3/8" = 1' - 0"

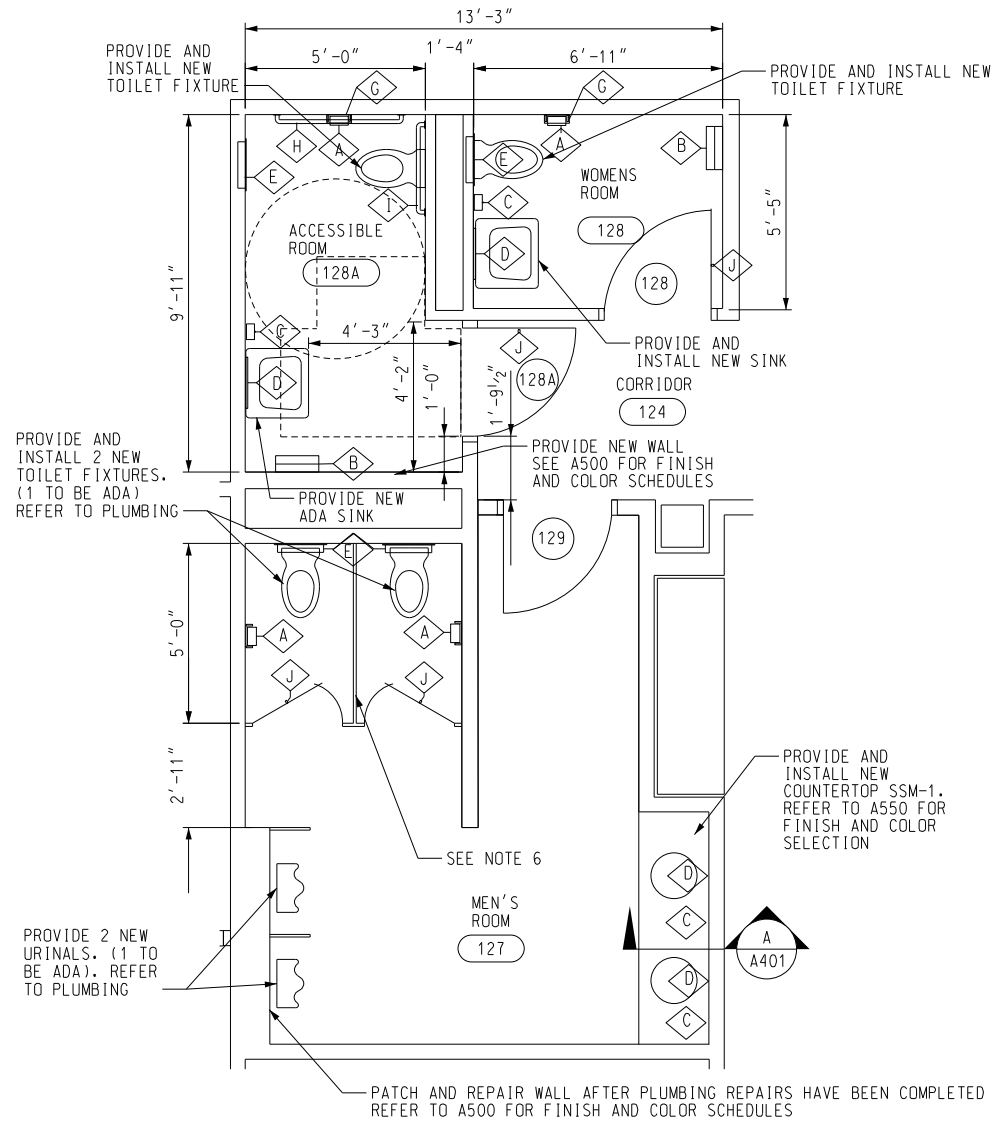

2 RESTROOM NEW WORK PLAN  
A400 SCALE: 3/8" = 1' - 0"

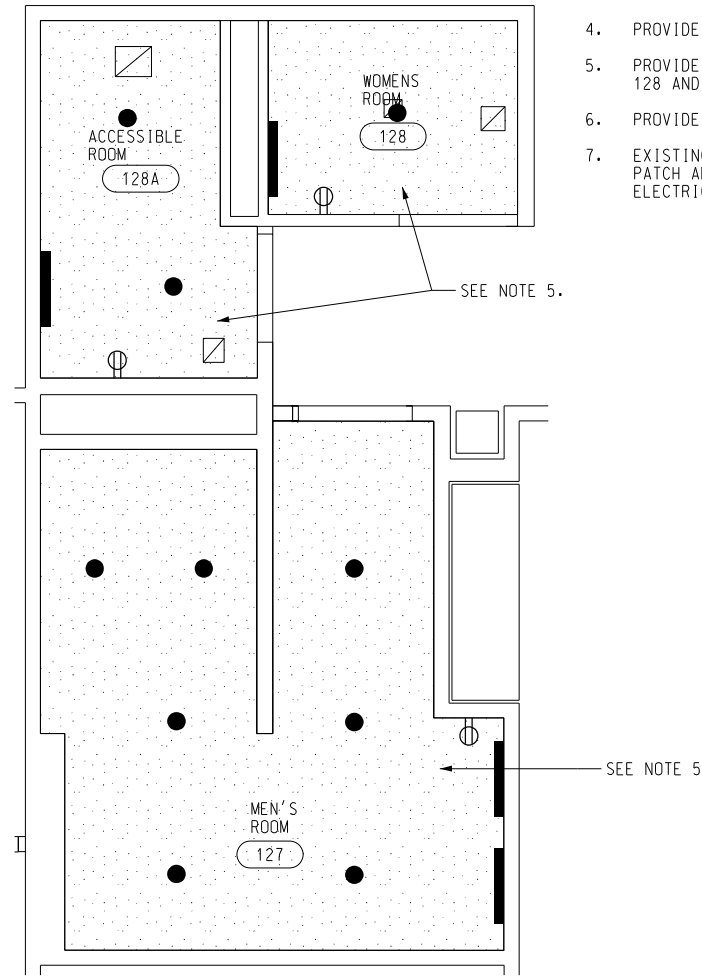

3 RESTROOM NEW RCP  
A400 SCALE: 3/8" = 1' - 0"

DEMOLITION KEYNOTES

- 1 REMOVE EXISTING CERAMIC TILE
- 2 REMOVE EXISTING LAVATORY AND COUNTER TOP
- 3 REMOVE EXISTING URINALS
- 4 REMOVE EXISTING WATERCLOSETS
- 5 REMOVE EXISTING TOILET PARTITIONS
- 6 REMOVE EXISTING DOOR

KEY	DESCRIPTION	EQUAL TO	MOUNTING TYPE
A	TOILET TISSUE DISPENSER	BOBRICK B-686	SURFACE MOUNTED
B	PAPER TOWEL DISPENSER AND WASTE RECEPTACLE	BOBRICK B-3699	SURFACE MOUNTED
C	SOAP DISPENSER	BOBRICK B-2111	SURFACE MOUNTED
D	MIRROR 18" X 30"	BOBRICK B-165 1830	SURFACE MOUNTED
E	SEAT COVER DISPENSER	BOBRICK B-301	RECESSED MOUNTED
F	SANITARY NAPKIN VENDOR	BOBRICK B-2706	SURFACE MOUNTED
G	SANITARY NAPKIN DISPOSAL	BOBRICK B-254	SURFACE MOUNTED
H	GRAB BARS 1-1/2" X 42"	BOBRICK B-6806 SERIES	SURFACE MOUNTED
I	GRAB BARS 1-1/2" X 36"	BOBRICK B-6806 SERIES	SURFACE MOUNTED
J	COAT HOOK	BOBRICK B-212	SURFACE MOUNTED

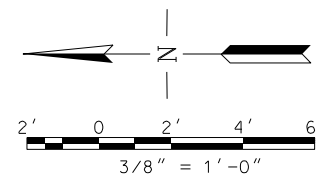

SCALES SHOWN FOR 22" X 34" SHEET. ADJUST SCALES FOR OTHER SIZES. PAGE OF

**WileyWilson**  
5901 Peachtree Dunwoody Rd.  
Bldg. C, Ste 515  
Atlanta, Georgia 30328-6055  
678.320.1888  
wileywilson.com  
WW JOB NUMBER: 219075.00

REV	APPROVED DATE	DESCRIPTION	JCN	REDLINE DATE	APVD

DEPARTMENT OF TRANSPORTATION  
FEDERAL AVIATION ADMINISTRATION

FORT LAUDERDALE AIRPORT TRAFFIC CONTROL TOWER  
MAJOR IMPROVEMENTS  
ARCHITECTURE  
RESTROOM DEMOLITION AND NEW WORK

FT LAUDERDALE (INTERNATIONAL) FL

REVIEWED BY	SUBMITTED BY	APPROVED BY
DESIGNED	GMR	ISSUED BY
DRAWN	GMR	ATLANTA TERMINAL ENGINEERING CENTER
CHECKED	NXE	

SUBMITTER'S TITLE - CIVIL ENGINEER	APPROVER'S TITLE - MANAGER
DATE JAN 31, 2020	JCN 1508912
DRAWING NO	FLL-D-TRACO-A400



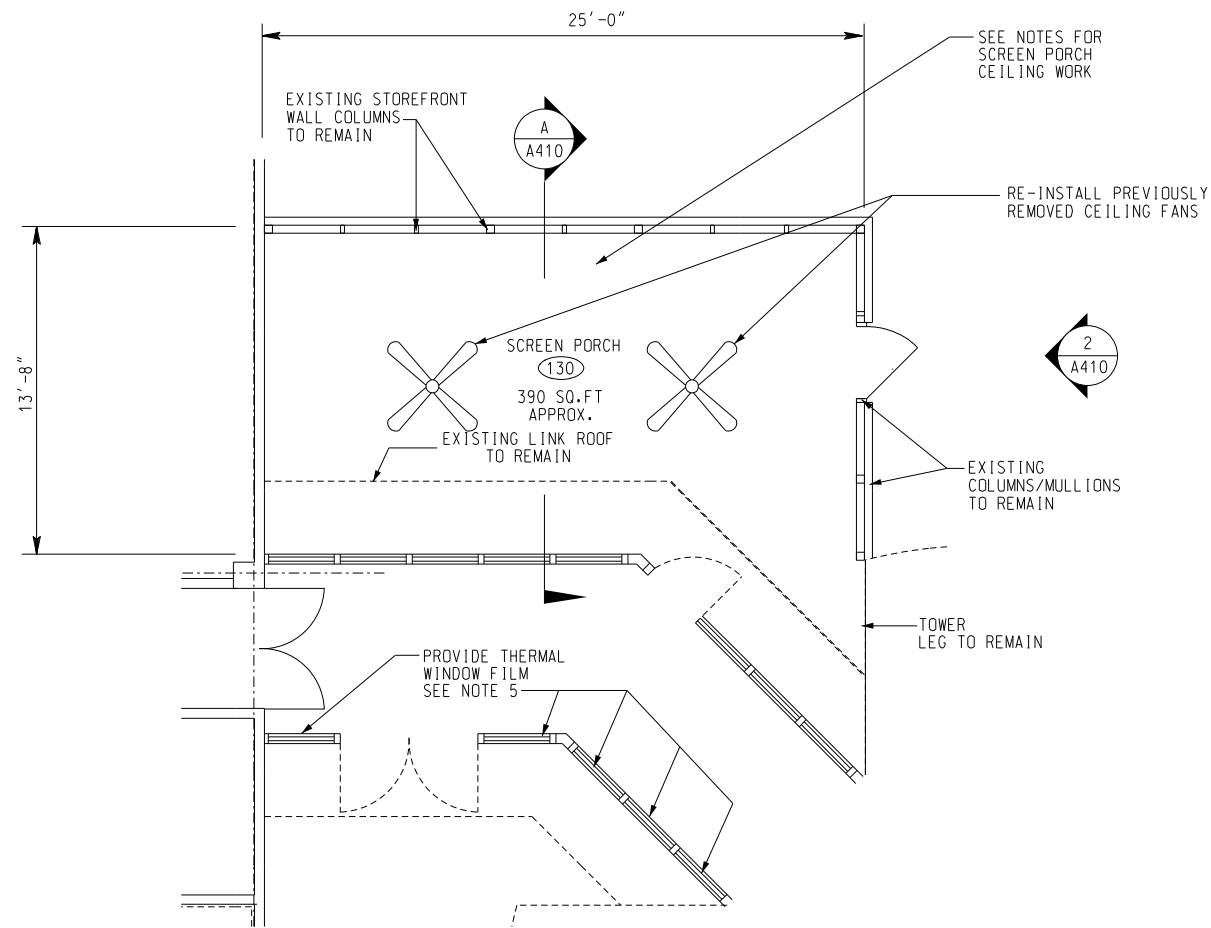

1 SCREEN PORCH FLOOR PLAN  
A410 SCALE: 1/4" = 1' - 0"

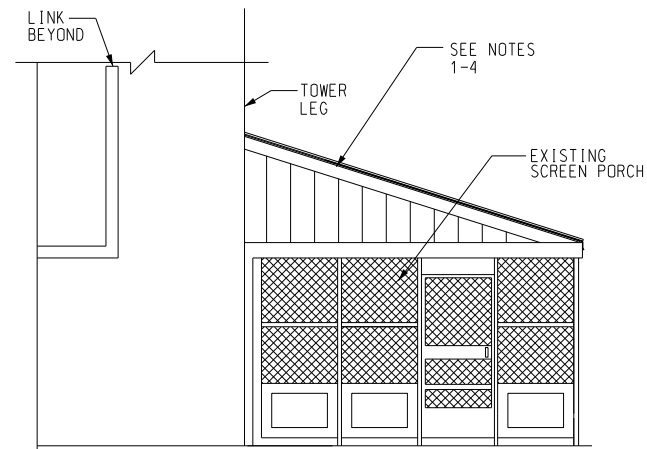

2 ELEVATION  
A410 SCALE: 1/4" = 1' - 0"

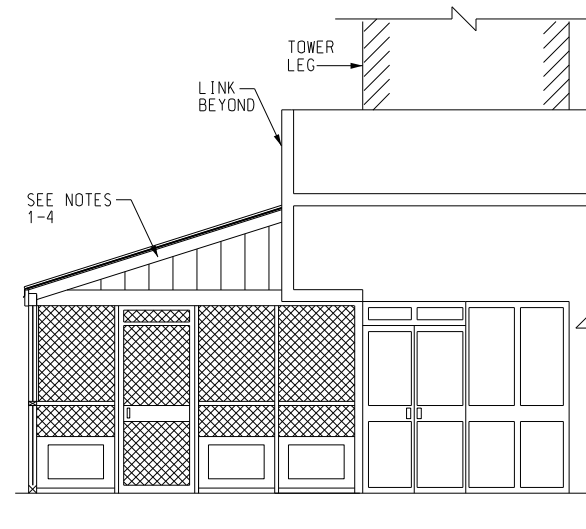

A SECTION  
A410 SCALE: 1/4" = 1' - 0"

NOTES

- REMOVE EXISTING PLYWOOD CEILING. CLEAN WOOD STRUCTURE APPLY BONDING PRIME, APPLY INTUMESCENT PAINT, ALLOW TO DRY FOR 24 HOURS. APPLY TOP COAT PAINT.
  - INSTALL NEW EXTERIOR GYPSUM CEILING BOARD DIRECTLY TO WOOD FRAMING APPLY PRIME, INTUMESCENT PAINT ALLOW TO DRY FOR 24 HOURS. APPLY TOP COAT PAINT.
  - EXTERIOR GYPSUM BOARD KNOWN ACCEPTABLE SOURCE:  
"USG"  
USG 5/8" FIRECODE "C" CORE SHEETROCK BRAND EXTERIOR GYPSUM CEILING BOARD, OR APPROVED EQUAL
  - INTUMESCENT PAINT KNOWN ACCEPTABLE SOURCE:  
"CONTEGO"  
CONTEGO INTERNATIONAL OR APPROVED EQUAL
  - WINDOW FILM KNOWN ACCEPTABLE SOURCE:  
"THERMAL WINDOW FILM"  
ARC WINDOW FILM OR APPROVED EQUAL
- WINDOW FILM TO BE INSTALLED ON THE INSIDE OF THE GLASS, AT THE LINK'S WEST WALL.

SCALES SHOWN FOR 22" X 34" SHEET. ADJUST SCALES FOR OTHER SIZES. PAGE OF



**WileyWilson**  
5901 Peachtree Dunwoody Rd.  
Bldg. C, Ste 515  
Atlanta, Georgia 30328-6055  
678.320.1888  
wileywilson.com

WW JOB NUMBER: 219075.00

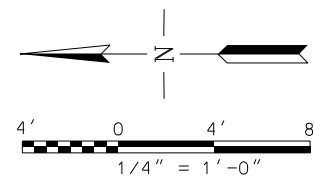



REV	APPROVED DATE	DESCRIPTION	JCN	REDLINE DATE	APVD
DEPARTMENT OF TRANSPORTATION FEDERAL AVIATION ADMINISTRATION					
FORT LAUDERDALE AIRPORT TRAFFIC CONTROL TOWER MAJOR IMPROVEMENTS ARCHITECTURE SCREENED-IN PORCH					
FT LAUDERDALE (INTERNATIONAL)			FL		
REVIEWED BY	SUBMITTED BY		APPROVED BY		
	SUBMITTER'S TITLE - CIVIL ENGINEER		APPROVER'S TITLE - MANAGER		
DESIGNED	GMR	ISSUED BY	DATE	JCN	
DRAWN	GMR	ATLANTA TERMINAL ENGINEERING CENTER	JAN 31, 2020	1508912	
CHECKED	NXE		DRAWING NO	FLL-D-TRACO-A410	REV

ROOM FINISH SCHEDULE										
ROOM NUMBER	ROOM NAME	FLOOR	BASE	WALL				CEILING		REMARKS
				NORTH	EAST	SOUTH	WEST	FINISH	HEIGHT	
100	VESTIBULE	VCT-1	RB-1	P-1	P-1	P-1	P-1	ACT-1	9'-0"	
101	CORRIDOR	VCT-1	RB-1	P-1	P-1	P-1	P-1	ACT-1	9'-0"	
102	PLAYBACK ROOM	CPT-1	RB-1	P-1	P-1	P-1	P-1	ACT-1	9'-0"	
103	ASST AT	CPT-1	RB-1	P-1	P-1	P-1	P-1	ACT-1	9'-0"	
104	TRAINING/STORAGE	CPT-1	RB-1	P-1	P-1	P-1	P-1	ACT-1	9'-0"	
105	AF/AT ADMIN STORAGE	CPT-1	RB-1	P-1	P-1	P-1	P-1	ACT-1	9'-0"	
106	EPDS	CPT-1	RB-1	P-1	P-1	P-1	P-1	ACT-1	9'-0"	
107	AT DEPUTY	CPT-1	RB-1	P-1	P-1	P-1	P-1	ACT-1	9'-0"	
108	AT MANAGER	CPT-1	RB-1	P-1	P-1	P-1	P-1	ACT-1	9'-0"	
109	SECRETARY	CPT-1	RB-1	P-1	P-1	P-1	P-1	ACT-1	9'-0"	
110	AF SSC	CPT-1	RB-1	P-1	P-1	P-1	P-1	ACT-1	9'-0"	
111	RADAR COORDINATOR	CPT-1	RB-1	P-1	P-1	P-1	P-1	ACT-1	9'-0"	
112	NAV/COM COORDINATOR	CPT-1	RB-1	P-1	P-1	P-1	P-1	ACT-1	9'-0"	
113	MECHANICAL ROOM	-	-	-	-	-	-	-	-	
114	CORRIDOR	VCT-1	RB-1	P-1	P-1	P-1	P-1	ACT-1	9'-0"	
115	AF STORAGE	-	-	-	-	-	-	-	-	
116	CONFERENCE ROOM	VCT-1	RB-1	P-1	P-1	P-1	P-1	ACT-1	9'-0"	
117	CORRIDOR	VCT-1	RB-1	P-1	P-1	P-1	P-1	ACT-1	9'-0"	
118	EQUIPMENT ROOM	-	-	-	-	-	-	-	-	
119	STORAGE	-	-	-	-	-	-	-	-	
120	STORAGE	-	-	-	-	-	-	-	-	
121	TELCO	-	-	-	-	-	-	-	-	
122	CORRIDOR	VCT-1	RB-1	P-1	P-1	P-1	P-1	ACT-1	9'-0"	
123	JANITOR	VCT-1	RB-1	P-1	P-1	P-1	P-1	ACT-1	9'-0"	
124	CORRIDOR	VCT-1	RB-1	P-1	P-1	P-1	P-1	ACT-1	9'-0"	
125	BREAKROOM	VCT-1	RB-1	P-1	P-1	P-1	P-1	ACT-1	9'-0"	
126	LOCKER ROOM	VCT-1	RB-1	P-1	P-1	P-1	P-1	ACT-1	9'-0"	
127	MEN'S ROOM	CT-1	CT-2	CT-3	CT-3	CT-3	CT-3	GYP/P-2	9'-0"	
128	WOMEN'S ROOM	CT-1	CT-2	CT-3	CT-3	CT-3	CT-3	GYP/P-2	9'-0"	
128A	ACCESSIBLE ROOM	CT-1	CT-2	CT-3	CT-3	CT-3	CT-3	GYP/P-2	9'-0"	
129	VESTIBULE	VCT-1	RB-1	P-1	P-1	P-1	P-1	ACT-1	9'-0"	
130	SCREEN PORCH	-	-	-	-	-	-	P-2	VARIES	SEE A410

INTERIOR COLOR SELECTIONS	
CARPET (CPT) CPT-1 INTERFACE, STYLE: 1467802500, FOLIO II (50CM X 50CM) COLOR: 9646 STEEL CPT-2 FOR THE TOWER - CAB	PAINT (P) P-1 SHERWIN WILLIAMS 6253 "OLYMPUS WHITE" P-2 SHERWIN WILLIAMS 7006 "EXTRA WHITE" (EXPOSED STRUCTURE ABOVE)
RUBBER BASE (RB) RB-1 4" COVED WALL BASE COLOR EQUAL TO "ROPPE P129 DOLPHIN"	PLASTIC LAMINATE (PLAM) PLAM-1 EQUAL TO FORMICA "7884-58 CHESTNUT WOODLINE, MATTE FINISH."
SOLID SURFACE MATERIAL (SSM) SSM-1 EQUAL TO DUPONT CORIAN "SILT".	TOILET PARTITIONS (TP) TP-1 KNICKERBOCKER - METROPOLITAN STYLE FINISH: STAINLESS STEEL FINISH
CERAMIC TILE (CT) CT-1 AMERICAN OLEAN 2"x2" UNGLAZED FLOOR TILES - GROUP 1 A24 "ALMOND" UNGLAZED. A43 "LIGHT SMOKE" UNGLAZED. CT-2 AMERICAN OLEAN 4-1/4" HIGH BASE CONSISTING OF 2" SQUARES OF "A43 LIGHT SMOKE" UNGLAZED CT-3 AMERICAN OLEAN 6" X 6" GLAZED WALL TILE - "0012 GLOSS ALMOND"	RESILIENT FLOORING (VCT) - VINYL COMPOSITE TILE VCT-1 COLOR EQUAL TO "AZROCK VINYL ENHANCED TILE, AZTERRA AT-104 GREY ROCK."

NOTES:

1. PRIOR TO ORDERING ANY MATERIALS, PROVIDE COLOR SAMPLES, REFLECTING ALL FINISHES NOTED ABOVE, AND ANY CONTRACTOR SUBSTITUTED FINISHES, TO RE FOR APPROVAL.
2. ALL SOLID SURFACE MATERIALS SHALL BE SSM-1, UNO.
3. ALL PLASTIC LAMINATES SHALL BE PLAM-1, UNO.

SCALES SHOWN FOR 22" X 34" SHEET. ADJUST SCALES FOR OTHER SIZES.				PAGE		OF			
  <b>WileyWilson</b> 5901 Peachtree Dunwoody Rd. Bldg. C, Ste 515 Atlanta, Georgia 30328-6055 678.320.1888 wileywilson.com WW JOB NUMBER: 219075.00				REV	APPROVED DATE	DESCRIPTION	JCN	REDLINE DATE	APVD
				DEPARTMENT OF TRANSPORTATION FEDERAL AVIATION ADMINISTRATION  FORT LAUDERDALE AIRPORT TRAFFIC CONTROL TOWER MAJOR IMPROVEMENTS ARCHITECTURAL FINISH AND COLOR SCHEDULES  FT LAUDERDALE (INTERNATIONAL) FL				REVIEWED BY	SUBMITTED BY
				SUBMITTER'S TITLE - CIVIL ENGINEER		APPROVER'S TITLE - MANAGER			
				DESIGNED	GMR	ISSUED BY	DATE	JCN	REV
				DRAWN	GMR	ATLANTA TERMINAL ENGINEERING CENTER	JAN 31, 2020	1508912	
				CHECKED	NXE	DRAWING NO	FLL-D-TRACO-A500		

DOOR SCHEDULE																													
LOCATION			DOOR			SCHEDULE				FRAME SCHEDULE			HARDWARE SCHEDULE					SECURITY DOOR MATRIX						SIGN					
LEVEL/FLOOR	DOOR #	DOOR LOCATION	REMOVE EXIST AND INSTALL NEW DOOR AND FRAME	INSTALL NEW DOOR	NEW HARDWARE ONLY	WIDTH	HEIGHT	THICK.	MATERIAL	FINISH	TYPE	TYPE	MATERIAL	FINISH	PAIR HINGES TOTAL	DOOR CLOSER	WEATHER STRIP	LOCK SET TYPE	EXT. RATED	FIRE RATED									
GROUND	B-4	STAIRS			●	-	-	-	-	-	-	-	-	-	-	●	-	P	-	-	-	-	-	-	-	-	-	-	-
SECOND	C-2	CABLE CHASE	●			3'-0"	7'-0"	1 3/4"	STL	PAINT	(A)	(1)	STL	PAINT	1.5	●	●	D	●	90									
	C-3	CABLE CHASE	●			3'-0"	7'-0"	1 3/4"	STL	PAINT	(A)	(1)	STL	PAINT	1.5	●	●	D	●	90									
	C-4	STAIRS	●			3'-0"	7'-0"	1 3/4"	STL	PAINT	(A)	(1)	STL	PAINT	1.5	●	●	P	●	90									
SUBJUNCTION	SJ1-2	CABLE CHASE			●	-	-	-	-	-	-	-	-	-	-	●	-	D	-	-									
JUNCTION	J-1	ELEVATOR MACHINE			●	-	-	-	-	-	-	-	-	-	-	●	-	D	-	-									

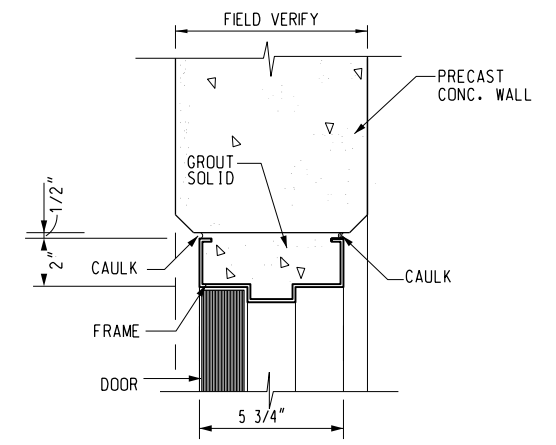

1 DOOR HEAD  
A505 SCALE: 3" = 1'-0"

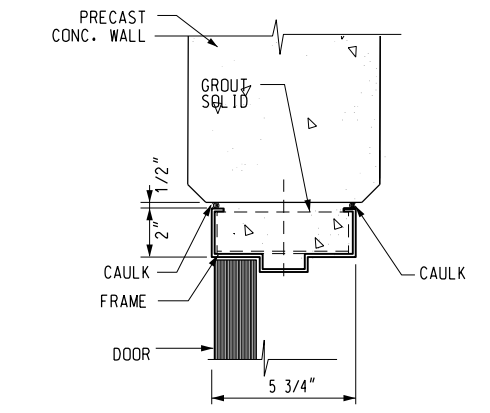

2 JAMB DET.  
A505 SCALE: 3" = 1'-0"

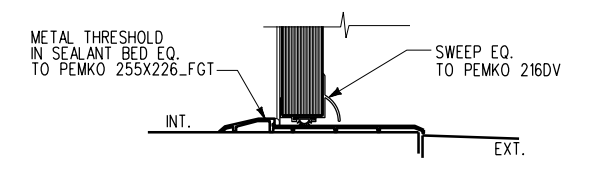

3 EXTERIOR THRESHOLD  
A505 SCALE: 3" = 1'-0"

DOOR HARDWARE DESCRIPTION						
DESG.	FUNCTION	DESCRIPTION	OUTSIDE LEVER		INSIDE LEVER	
			LOCKED BY	UNLOCKED BY	LOCKED BY	UNLOCKED BY
● P	PASSAGE	TURNING THE INSIDE LEVER, OR ROTATING THE OUTSIDE LEVER	CANNOT BE LOCKED	ALWAYS UNLOCKED	CANNOT BE LOCKED	ALWAYS UNLOCKED
● D	STOREROOM	TURNING THE KEY IN THE OUTSIDE LEVER, OR ROTATING THE INSIDE LEVER	ALWAYS FIXED	CANNOT BE UNLOCKED	CANNOT BE LOCKED	ALWAYS UNLOCKED

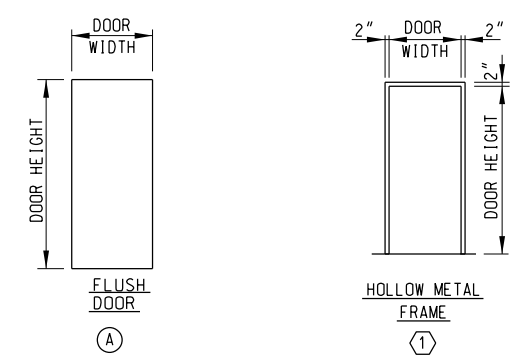

1 DOOR AND FRAME TYPE  
A505 NOT TO SCALE

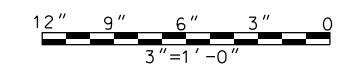

SCALES SHOWN FOR 22" X 34" SHEET. ADJUST SCALES FOR OTHER SIZES. PAGE OF

**WileyWilson**  
5901 Peachtree Dunwoody Rd.  
Bldg. C, Ste 515  
Atlanta, Georgia 30328-6055  
678.320.1888  
wileywilson.com  
WW JOB NUMBER: 219075.00

REV	APPROVED DATE	DESCRIPTION	JCN	REDLINE DATE	APVD
DEPARTMENT OF TRANSPORTATION <b>FEDERAL AVIATION ADMINISTRATION</b>  <b>FORT LAUDERDALE AIRPORT TRAFFIC CONTROL TOWER            MAJOR IMPROVEMENTS            ARCHITECTURAL            DOOR TYPES, SCHEDULE AND DETAILS</b>					
FT LAUDERDALE (INTERNATIONAL)			FL		
REVIEWED BY	SUBMITTED BY		APPROVED BY		
DESIGNED	GMR	ISSUED BY	APPROVER'S TITLE - MANAGER		
DRAWN	GMR	ATLANTA TERMINAL ENGINEERING CENTER	DATE	JAN 31, 2020	JCN 1508912
CHECKED	NXE		DRAWING NO	FLL-D-TRACO-A505	



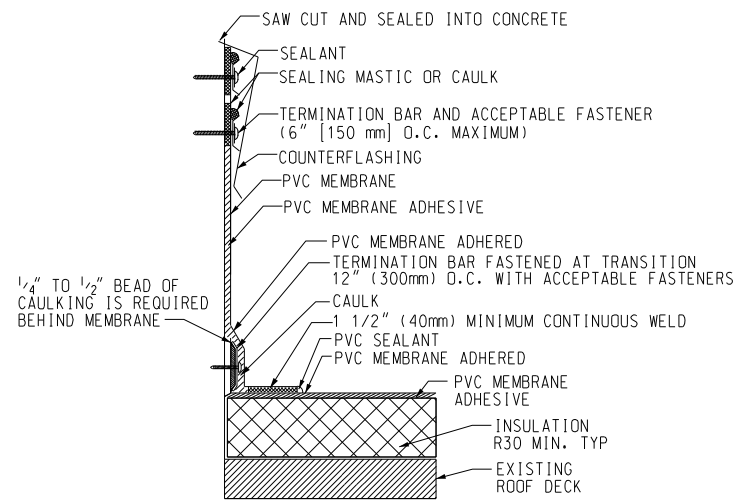

1 VERTICAL FLASHING DETAIL  
A610 SCALE: NONE

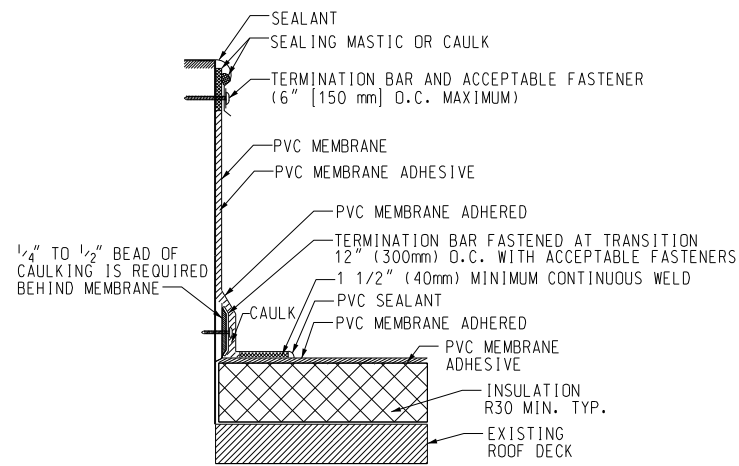

2 OUTSIDE FLASHING DETAIL  
A610 SCALE: NONE

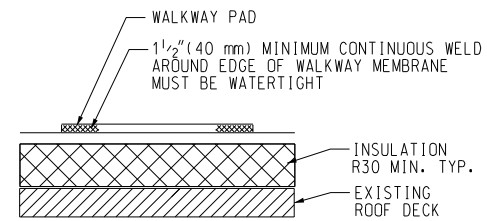

3 WALKWAY PAD DETAIL  
A610 SCALE: NONE

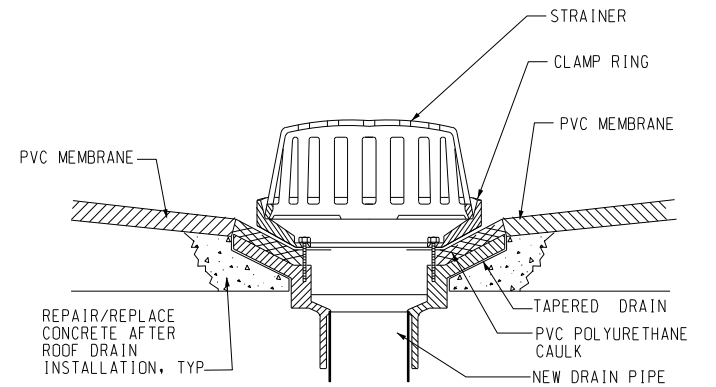

4 DRAIN DETAIL  
A610 SCALE: NONE

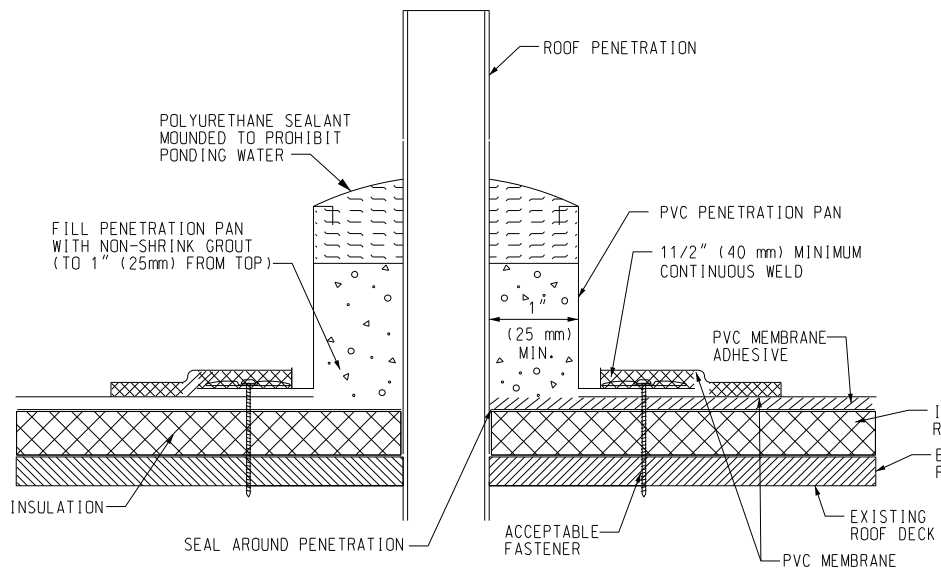

5 PITCH POCKET DETAIL  
A610 SCALE: NONE

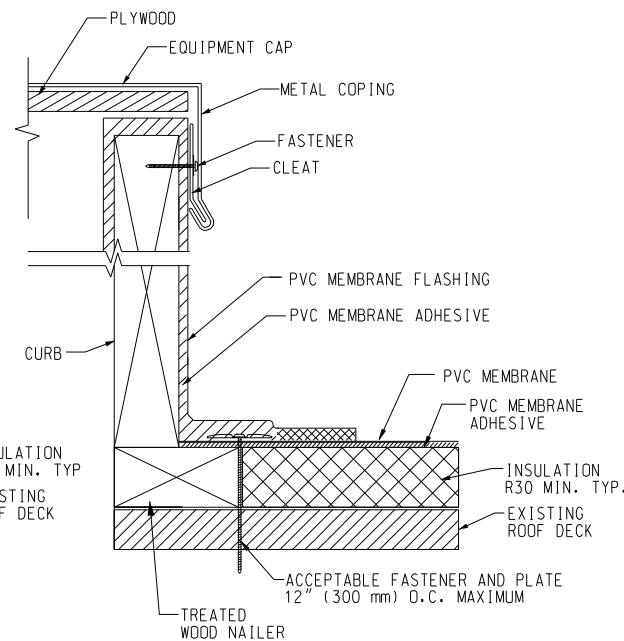

6 CURB CAP DETAIL  
A610 SCALE: NONE

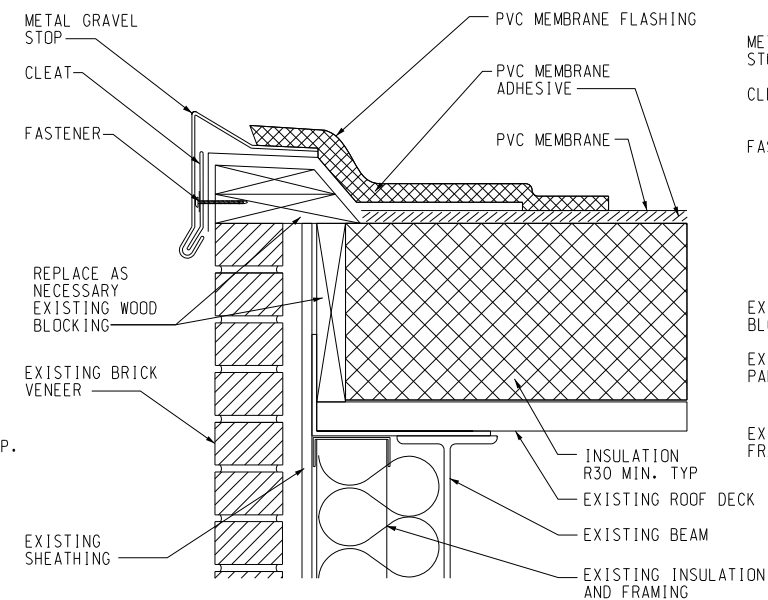

7 ROOF EDGE DETAIL 1  
A610 SCALE: NONE

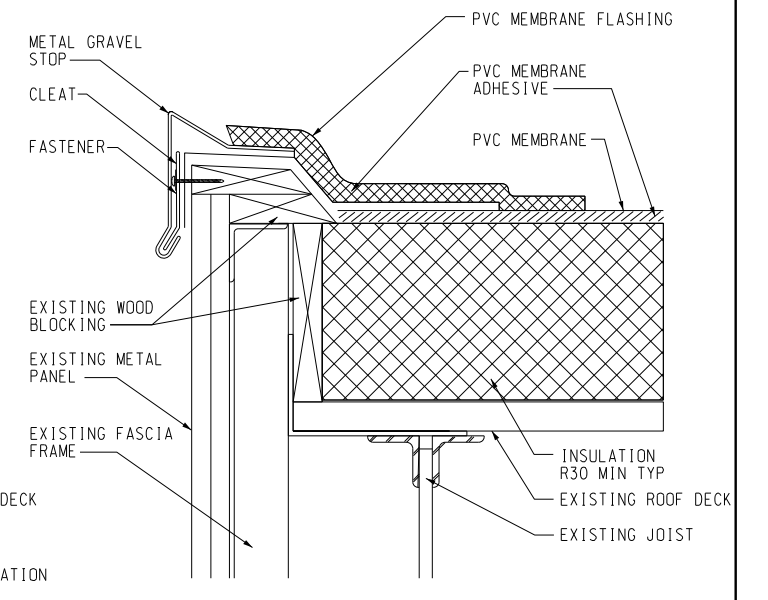

8 ROOF EDGE DETAIL 2  
A610 SCALE: NONE

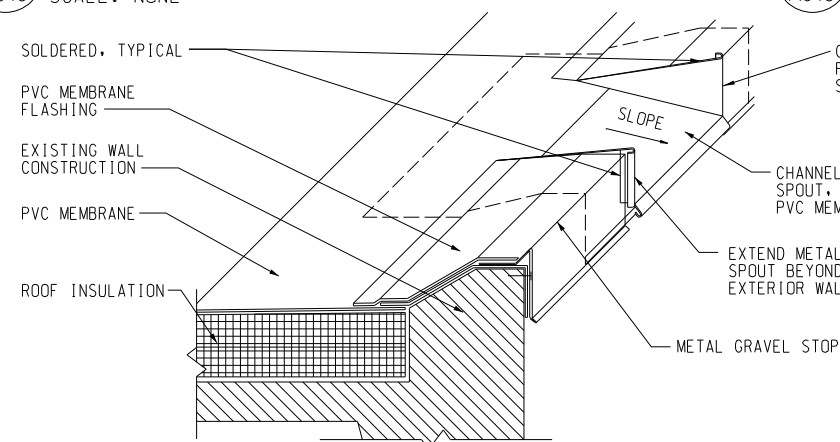

9 OVERFLOW SCUPPER DETAIL  
A610 SCALE: NONE

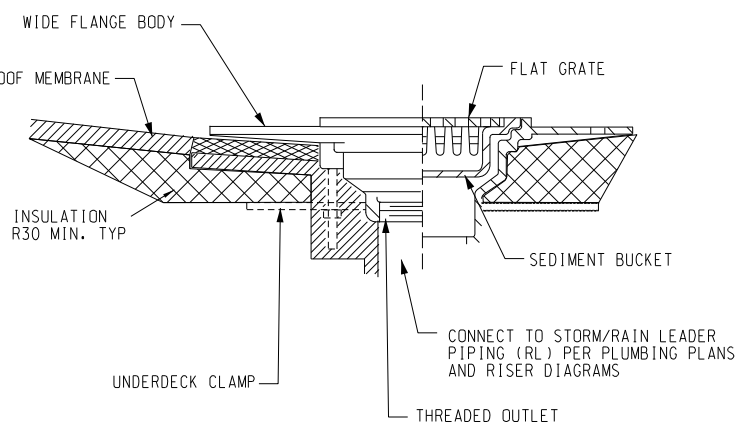

10 DRAIN AND SUMP DETAIL  
A610 SCALE: NONE

SCALES SHOWN FOR 22" X 34" SHEET. ADJUST SCALES FOR OTHER SIZES. PAGE OF

STATE OF GEORGIA  
NEIL LESSER  
REGISTERED ARCHITECT  
01/31/2020

WileyWilson  
5901 Peachtree Dunwoody Rd.  
Bldg. C, Ste 515  
Atlanta, Georgia 30328-6055  
678.320.1888  
wileywilson.com  
WW JOB NUMBER: 219075.00

REV	APPROVED DATE	DESCRIPTION	JCN	REDLINE DATE	APVD

DEPARTMENT OF TRANSPORTATION  
FEDERAL AVIATION ADMINISTRATION

FORT LAUDERDALE AIRPORT TRAFFIC CONTROL TOWER  
MAJOR IMPROVEMENTS  
ARCHITECTURE  
ROOF DETAILS

FT LAUDERDALE (INTERNATIONAL) FL

REVIEWED BY	SUBMITTED BY	APPROVED BY
DESIGNED	ISSUED BY	APPROVER'S TITLE - MANAGER
DRAWN	DATE JAN 31, 2020	JCN 1508912
CHECKED	ATLANTA TERMINAL ENGINEERING CENTER	DRAWING NO. FLL-D-TRACO- A610

## HEATING, VENTILATION & AIR CONDITIONING LEGEND

			HEATING HOT WATER RETURN LINE		HUMIDIFIER
	ADJUSTABLE THERMOSTAT WITH ALPHANUMERIC DISPLAY		MOTOR OPERATED DAMPER		FLOW ELEMENT, DUCT-MOUNTED
	EQUIPMENT (REFER TO SCHEDULE)		FLOW METER		HUMIDITY TRANSMITTER
	DUCT SIZE - FIRST FIGURE IS SIDE SHOWN		FLEXIBLE PIPE CONNECTION		THERMOMETER, AVERAGING
	LINED DUCTWORK		FLEXIBLE DUCT CONNECTION		THERMOMETER, NON-AVERAGING
	CEILING DIFFUSER FOUR WAY BLOW U.N.O. (REFER TO SCHEDULE)		CHILLED WATER, COOLING COIL		THERMOSTAT, LOW-TEMPERATURE PROTECTION
	RETURN AIR GRILLE (REFER TO SCHEDULE)		DIRECT EXPANSION, COOLING COIL		DIFFERENTIAL-PRESSURE SWITCH
	LOUVER AND SCREEN REFER TO PLANS FOR SIZE		ELECTRIC DUCT HEATER, HEATING COIL		DIFFERENTIAL-PRESSURE INDICATOR
	CONDENSATE DRAIN TRAP (SEE DETAILS)		ELECTRIC, HEATING COIL		DAMPER ACTUATOR
	DUCT SECTION POSITIVE PRESSURE		HOT WATER, HEATING COIL		Y-STRAINER WITH BLOW-OFF VALVE AND COUPLING
	DUCT SECTION NEGATIVE PRESSURE		SUPPLY FAN		Y-STRAINER
	SPIN-IN FITTING WITH MANUAL DAMPER/FLEX. DUCT		HUMIDISTAT		3-WAY CONTROL VALVE WITH MOTOR OPERATOR
	DUCT SECTION ROUND		HYDROGEN SENSOR		2-WAY CONTROL VALVE WITH MOTOR OPERATOR
	MANUAL VOLUME DAMPER		CHILLER		GATE VALVE
	COMBINATION FIRE AND SMOKE DAMPER		AUTOMATIC DAMPER PARALLEL BLADE WITH SEALS		GLOBE VALVE
	FIRE DAMPER		TEMPERATURE TRANSMITTER DUCT-MOUNTED		CHECK VALVE
	DUCT SMOKE DETECTOR		TEMPERATURE TRANSMITTER, DUCT-MOUNTED, AVERAGING		DOUBLE CHECK BACKFLOW PREVENTER VALVE
	90° LOW PRESSURE ELBOW (PROVIDE DOUBLE THICKNESS TURNING VANE)		SMOKE DETECTOR, DUCT-MOUNTED		PRESSURE REDUCING VALVE
	EXISTING WORK AS SHOWN LIGHT SOLID LINE		PRESSURE TRANSMITTER		COMBINATION BALANCING AND FLOW MEASURING DEVICE
	EXISTING WORK SHALL BE REMOVED AS SHOWN CROSS-HATCHED		PRESSURE INDICATOR (GAUGE)		UNION
	INTERFACING POINT BETWEEN EXISTING WORK TO REMAIN AND EXISTING WORK TO BE REMOVED		VARIABLE SPEED DRIVE		EXPANSION VALVE, THERMOSTATIC
	NEW WORK SHOWN AS HEAVY SOLID LINE		VARIABLE FREQUENCY DRIVE		SOLENOID VALVE
	CONNECTING POINT BETWEEN NEW WORK AND EXISTING WORK		AIR FLOW MEASURING STATION		BOILER
	ACTUATOR ELECTRIC OR ELECTRONIC		DIFFERENTIAL - PRESSURE TRANSMITTER		PLATE AND FRAME HEAT EXCHANGER
	SQUARE-TO-ROUND TRANSITION		CURRENT RELAY		EXISTING FIRE DAMPER
	CHILLED WATER SUPPLY LINE		FILTER		
	CHILLED WATER RETURN LINE				
	DOMESTIC COLD WATER PIPING				
	HEATING HOT WATER SUPPLY LINE				
	BAS - BUILDING AUTOMATION SYSTEM				

## HVAC GENERAL NOTES

1. THESE DRAWINGS ARE SCHEMATIC IN NATURE AND ARE NOT INTENDED TO SHOW ALL POSSIBLE CONDITIONS (DO NOT SCALE FOR LOCATIONS). IT IS INTENDED THAT A COMPLETE HEATING, VENTILATING AND AIR CONDITIONING SYSTEM (HVAC) BE PROVIDED WITH ALL NECESSARY EQUIPMENT, APPURTENANCES AND CONTROLS. THE CONTRACTOR SHALL CAREFULLY REVIEW ALL THE CONTRACT DOCUMENTS AND COORDINATE BETWEEN ALL TRADES PRIOR TO SUBMITTING SHOP DRAWINGS. THE CONTRACTOR SHALL VERIFY ALL SIZES, MATERIALS, AND TEMPERATURE AND PRESSURE RATINGS BEFORE ORDERING OR INSTALLING ANY MATERIALS OR EQUIPMENT. THE CONTRACTOR SHALL PREPARE INSTALLATION INSTRUCTIONS AND FABRICATION DRAWINGS PRIOR TO ACTUAL INSTALLATION.
2. REFER TO EACH DRAWING FOR NOTES SPECIFIC TO THAT DRAWING SHEET.
3. THIS PROJECT IS A RENOVATION OF AN EXISTING FACILITY, AND PREVIOUS RECORD DRAWINGS FORM THE BASIS FOR MANY OF THESE DRAWINGS. THE CONTRACTOR SHALL FIELD VERIFY ALL DIMENSIONS PRIOR TO FABRICATION OR PURCHASE OF EQUIPMENT, MATERIALS, AND ASSEMBLIES. THERE MAY EXIST FIELD CONDITIONS WHICH DIFFER FROM THOSE SHOWN ON THESE DRAWINGS. ANY SUCH DEVIATIONS SHALL BE BROUGHT TO THE ATTENTION OF THE FAA CONTRACTING OFFICER REPRESENTATIVE FOR RESOLUTION BEFORE PROCEEDING WITH ANY CONSTRUCTION, FABRICATION, OR MATERIAL/EQUIPMENT PURCHASE WHICH WOULD BE UNUSABLE UNDER THOSE CIRCUMSTANCES.
4. THE CONTRACTOR SHALL BE RESPONSIBLE FOR THE SAFETY OF CONTRACTOR'S PERSONNEL EMPLOYED ON THIS PROJECT AND IN PARTICULAR, WHEN WORKING IN CONFINED SPACES. THE CONTRACTOR SHALL COMPLY WITH ALL OCCUPATIONAL SAFETY HEALTH ADMINISTRATION (OSHA) REQUIREMENTS.
5. COORDINATE THE VOLTAGE AND PHASE OF EACH PIECE OF EQUIPMENT WITH DIVISION 26 (ELECTRICAL CONTRACT DOCUMENTS) PRIOR TO ORDERING. PROVIDE WRITTEN VERIFICATION OF COORDINATION WITH DIVISION 26 PRIOR TO INSTALLATION OF EQUIPMENT.
6. COORDINATE DUCTWORK AND PIPING WITH ELECTRICAL, STRUCTURAL, AND PLUMBING TRADES. MAKE OFFSETS AND TRANSITIONS SO AS NOT TO INTERFERE WITH OTHER TRADES WITHOUT ADDITIONAL EXPENSE TO THE GOVERNMENT.
7. ALL NEW CONTROL WIRING LOCATED ABOVE A SUSPENDED CEILING SHALL BE CONTAINED IN CONDUIT OR APPROVED CABLE TRAY. EXISTING CONDUIT MAY BE USED BUT ALL NEW WIRING IS REQUIRED. THE FAA CONTRACTING OFFICER REPRESENTATIVE SHALL APPROVE ALL EXISTING CONDUIT TO BE REUSED. ALL WIRING, PIPING, AND OTHER EQUIPMENT LOCATED IN AN AIR PLENUM SHALL BE PLENUM RATED.
8. ALL DAMPERS, DAMPER OPERATORS, AND FANS SHALL BE ACCESSIBLE. LOCATE ALL EQUIPMENT OR APPURTENANCES IN AREAS WITH ACCESSIBLE CEILINGS. THE CONTRACTOR MAY USE ACCESS PANELS FOR THOSE AREAS NOT EASILY ACCESSIBLE. ALL ACCESS PANEL LOCATIONS SHALL BE COORDINATED WITH THE CONTRACT DOCUMENTS AND APPROVED BY THE FAA CONTRACTING OFFICER REPRESENTATIVE PRIOR TO INSTALLATION OF EQUIPMENT.
9. ALL DUCT TRANSITIONS FROM SQUARE TO ROUND SHALL BE SMOOTH SQUARE TO ROUND TRANSITIONS, WITH MINIMUM PRESSURE DROP AND WITHOUT LEAKS.
10. DUCT SIZES ARE SHOWN AS INSIDE CLEAR DIMENSIONS. WHERE INTERNAL INSULATION IS CALLED FOR, DIMENSIONS SHALL BE INCREASED FOR THE THICKNESS OF THE INSULATION. SEE SPECIFICATION FOR THICKNESS.
11. ALL BRANCH DUCTWORK SHALL BE SIZED TO MATCH THE DIFFUSER INLET SERVED UNLESS NOTED OTHERWISE. FLEXIBLE DUCT TO DIFFUSERS SHALL BE INSTALLED FREE OF KINKS AND SAGS. MAXIMUM LENGTH OF FLEXIBLE DUCT SHALL BE 6'-0". ALL RUNOUT AND BRANCH DUCTS SHALL CONTAIN A MANUAL VOLUME DAMPER FOR BALANCING.
12. ALL DIFFUSERS SHALL HAVE FOUR-WAY BLOW UNLESS NOTED OTHERWISE. ADJUST ALL DIFFUSERS INSTALLED IN CORRIDORS OR WITHIN 3 FEET OF A WALL TO PROVIDE TWO-WAY OR THREE-WAY BLOW AWAY FROM OR PARALLEL TO WALLS.
13. ALL OPEN ENDED DUCTS SHALL BE REINFORCED WITH STEEL ANGLES (1-1/2" X 1-1/2" X 1/8") BOLTED OR RIVETED 6" ON CENTER (MAXIMUM) ALL AROUND THE PERIMETER OF THE DUCT MINIMUM 2 PER SIDE.
14. PROVIDE THERMOSTATS AND/OR HUMIDISTATS WHERE SHOWN ON THE DRAWINGS. MOUNT DEVICES CENTERED 48" ABOVE FINISHED FLOOR UNLESS NOTED OTHERWISE.
15. CONDENSATE DRAIN LINES ROUTED HORIZONTALLY SHALL SLOPE 1/8" PER FOOT DOWN IN THE DIRECTION OF FLOW. WHERE LOCATED IN A RETURN AIR PLENUM, THE CONDENSATE PIPING SHALL BE PLENUM-RATED.
16. ALL PIPING PENETRATIONS THROUGH FIRE-RATED WALLS AND FLOOR SLAB SHALL HAVE PIPE SLEEVES WITH FIRESTOPPING MATERIAL. CAULK ANNULAR SPACE BETWEEN PIPE AND SLEEVE. EXPOSED PIPE THROUGH WALLS SHALL HAVE ESCUTCHEONS.
17. INSTALL DUCTWORK AS HIGH AS POSSIBLE ABOVE CEILING TO AVOID CONFLICTS WITH CABLE TRAY, ETC.
18. CONTRACTOR SHALL PERFORM AIR DUCT CLEANING FOR ALL NEW DUCTWORK IN THE BASE BUILDING AND TOWER. REFER TO SPECIFICATION SECTION 23 31 13, METAL DUCTS.

## SPECIAL NOTES

- A. MINIMIZING HVAC EQUIPMENT DOWNTIME IS CRITICAL FOR THE PROPER OPERATION OF FAA EQUIPMENT. COORDINATE PHASING WITH THE FAA CONTRACTING OFFICER REPRESENTATIVE (COR). FOR MEASURES TO BE TAKEN PRIOR TO EQUIPMENT SHUT DOWN. THE CONTRACTOR SHALL PROVIDE TEMPORARY HEATING AND/OR COOLING SYSTEM DURING CONSTRUCTION AS REQUIRED TO ALL SPACES. THE TEMPORARY EQUIPMENT SHALL BE CAPABLE OF MAINTAINING SPACE TEMPERATURE REGARDLESS OF THE TIME OF YEAR WORK IS ACCOMPLISHED. THE FAA CONTRACTING OFFICER REPRESENTATIVE SHALL APPROVE THE TEMPORARY HEATING AND/OR COOLING SYSTEM TO BE USED TO MAINTAIN SPACE TEMPERATURE. ALL CRITICAL SPACES SHALL BE MAINTAINED AT 73°F. ALL OTHERS SHALL BE MAINTAINED @ 75°.
- B. CONTRACTOR SHALL SUPPLY EMERGENCY SERVICE RESPONSE FOR TEMPORARY SYSTEMS. CONTRACTOR SHALL GUARANTEE 4 HOUR RESPONSE TIME FROM NOTIFICATION TO ARRIVAL OF SERVICE PERSONNEL.
- C. DURING CONSTRUCTION, THE CONTRACTOR SHALL PROTECT ALL ELECTRONIC EQUIPMENT IN EQUIPMENT ROOMS, TELCO, TRACON, AND TOWER CAB WITH DROP CLOTH OR OTHER FAA COR APPROVED METHOD. THE PROTECTION SHALL BE REMOVED AND CLEANED AT THE END OF EACH WORK SHIFT.
- D. ALL WORK IN THE TRACON AND TOWER CAB SHALL BE PERFORMED BETWEEN 11:00 PM AND 4:30 AM OR HOURS NEGOTIATED WITH LOCAL FAA PERSONNEL AND CONTRACTING OFFICER REPRESENTATIVE DURING THE PRE-BID CONFERENCE.
- E. ALL WORK IN OCCUPIED AREAS, INCLUDING WORK ON TERMINAL UNITS, DUCTWORK, AND CEILING REPLACEMENT, SHALL BE PERFORMED BETWEEN 4:00 PM AND 7:00 AM OR HOURS NEGOTIATED WITH LOCAL FAA PERSONNEL AND CONTRACTING OFFICER REPRESENTATIVE DURING THE PRE-BID CONFERENCE.

Are these working hours true for the base building renovation work?

SCALES SHOWN FOR 22" X 34" SHEET. ADJUST SCALES FOR OTHER SIZES.		PAGE	OF
DEPARTMENT OF TRANSPORTATION FEDERAL AVIATION ADMINISTRATION  FORT LAUDERDALE AIRPORT TRAFFIC CONTROL TOWER MAJOR IMPROVEMENTS MECHANICAL HVAC LEGEND AND GENERAL NOTES			
FT LAUDERDALE (INTERNATIONAL)		FL	
REV	APPROVED DATE	DESCRIPTION	APPROVED BY
SUBMITTED BY		APPROVED BY	
SUBMITTER'S TITLE - CIVIL ENGINEER		APPROVER'S TITLE - MANAGER	
DESIGNED	JJS	ISSUED BY	DATE JAN 31, 2020 JCN 1508912
DRAWN	CRK	ATLANTA TERMINAL ENGINEERING CENTER	DRAWING NO. FLL-D-TRACO-M000
CHECKED	JJS		
Wiley Wilson 5901 Peachtree Dunwoody Rd. Bldg. C, Ste 515 Atlanta, Georgia 30328-6055 678.320.1888 wileywilson.com WW JOB NUMBER: 219075.00			



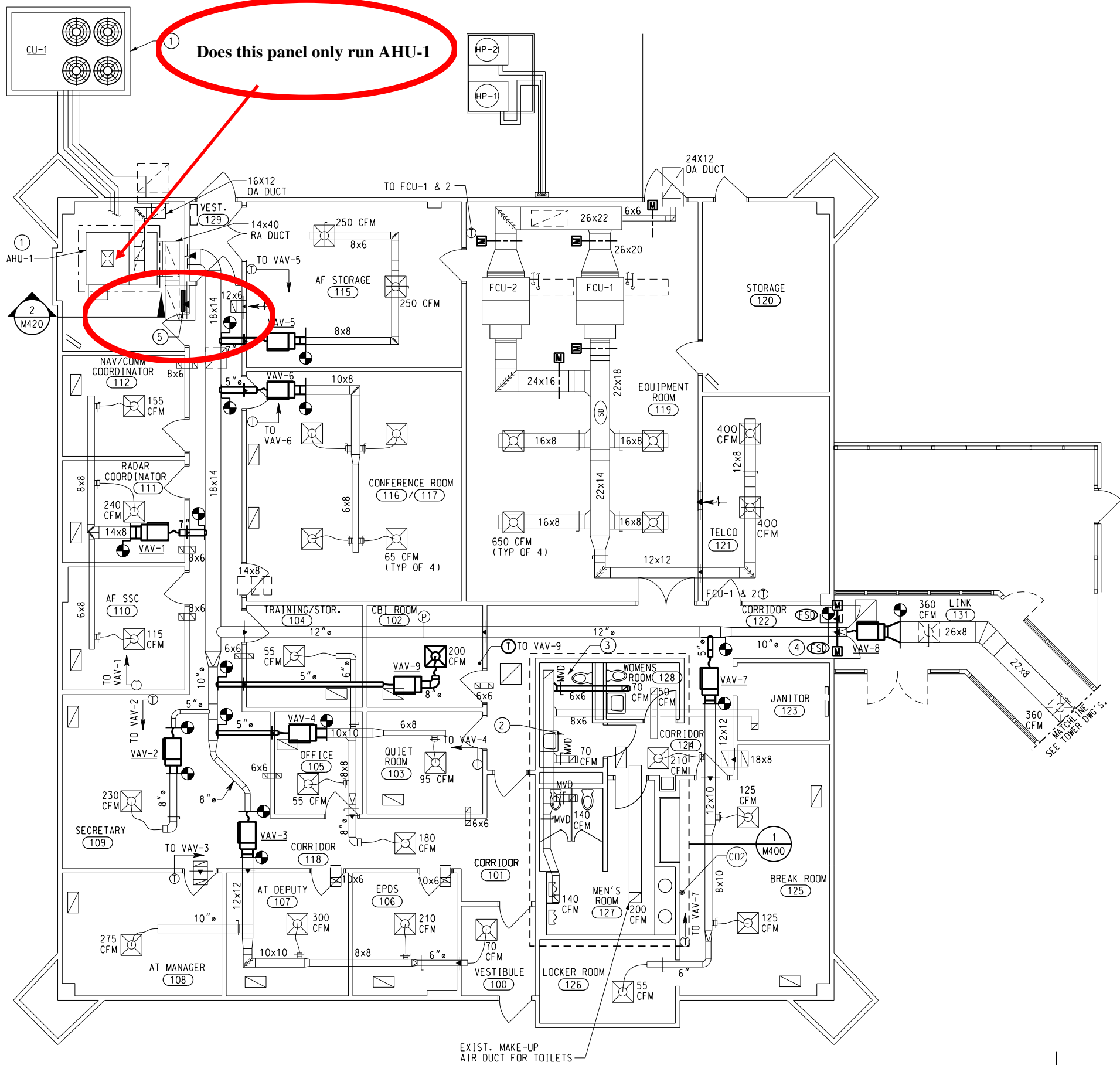

**NOTES**

- ① AHU-1 AND CU-1 EXISTING TO REMAIN. INTEGRATE WITH NEW DDC SYSTEM.
- ② PROVIDE MVD'S AT BATHROOM GRILLE TAKEOFFS AS SHOWN ON PLANS. PROVIDE ACCESS DOOR BENEATH IF ABOVE HARD CEILING IN LIEU OF MVD'S AT TAKEOFFS. DAMPERS AT EACH EXHAUST GRILLE ARE ACCEPTABLE.
- ③ ADD TAKE-OFF WITH MVD FOR EXHAUST IN WOMEN'S RESTROOM.
- ④ REPLACE FIRE-SMOKE DAMPER. COORDINATE POWER WITH ELECTRICAL CONTRACTOR. BOTH SUPPLY AND RETURN AIR DAMPER SHALL BE REPLACED (FSD-1, FSD-2). SEE SCHEDULE ON M500 FOR DETAILS.
- ⑤ REPLACE DDC CONTROL PANEL. COORDINATE POWER WITH ELECTRICAL.

**GENERAL**

- A. NEW WORK IS SHOWN AS HEAVY LINE ON PLANS AND EXISTING WORK SHOWN IS LIGHT SOLID LINE.
- B. CONTRACTOR SHALL PERFORM AIR FLOW TEST AND REBALANCE ALL EXISTING AND NEW AIR DEVICES TO AIR FLOW INDICATED.
- C. PROVIDE NEW AIR TERMINAL UNITS (VAV), WALL MOUNTED THERMOSTATS AS INDICATED, AND ASSOCIATED CONTROLS.
- D. WHERE NEW CONNECTION TO EXISTING IS INDICATED, THE CONTRACTOR SHALL FIELD VERIFY THE SIZE AND EXACT LOCATION OF THE EXISTING WORK AT THE POINT OF CONNECTION. NEW DUCT AND PIPE SIZE SHALL MATCH EXISTING.
- E. ALL NEW EXPOSED DUCTWORK SHALL BE INSULATED DOUBLE WALL DUCT AS PER SPECIFICATIONS, UNLESS OTHERWISE NOTED.
- F. SEE DRAWING TRACO-M000 FOR HVAC LEGEND, GENERAL NOTES, AND SPECIAL NOTES.
- G. WHERE FIRE OR FIRE/SMOKE DAMPERS ARE REMOVED IN CONJUNCTION WITH THIS WORK, THE REMOVED DAMPER SHALL BE REPLACED WITH THE SAME TYPE, RATING AND SHALL BE COORDINATED WITH THE FIRE ALARM AND ELECTRICAL CONTRACTORS.

**1** BASE BUILDING HVAC FLOOR PLAN - HVAC  
 M100 SCALE: 3/16" = 1' - 0"

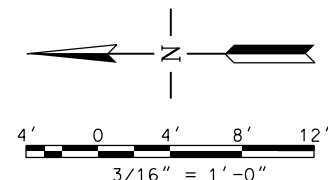

SCALES SHOWN FOR 22" X 34" SHEET. ADJUST SCALES FOR OTHER SIZES.		PAGE	OF
DEPARTMENT OF TRANSPORTATION <b>FEDERAL AVIATION ADMINISTRATION</b>			
<b>FORT LAUDERDALE AIRPORT TRAFFIC CONTROL TOWER          MAJOR IMPROVEMENTS          MECHANICAL          BASE BUILDING FLOOR PLAN - HVAC</b>			
FT LAUDERDALE		(INTERNATIONAL)	
REVIEWED BY	SUBMITTED BY	APPROVED BY	
SUBMITTER'S TITLE - CIVIL ENGINEER		APPROVER'S TITLE - MANAGER	
DESIGNED JJS	ISSUED BY	DATE JAN 31, 2020	JCN 1508912
DRAWN CRK	ATLANTA TERMINAL ENGINEERING CENTER	DRAWING NO	FLL-D-TRACO-M100
CHECKED JJS			
WILEY WILSON 5901 Peachtree Dunwoody Rd. Bldg. C, Ste 515 Atlanta, Georgia 30328-6055 678.320.1888 wileywilson.com WW JOB NUMBER: 219075.00			

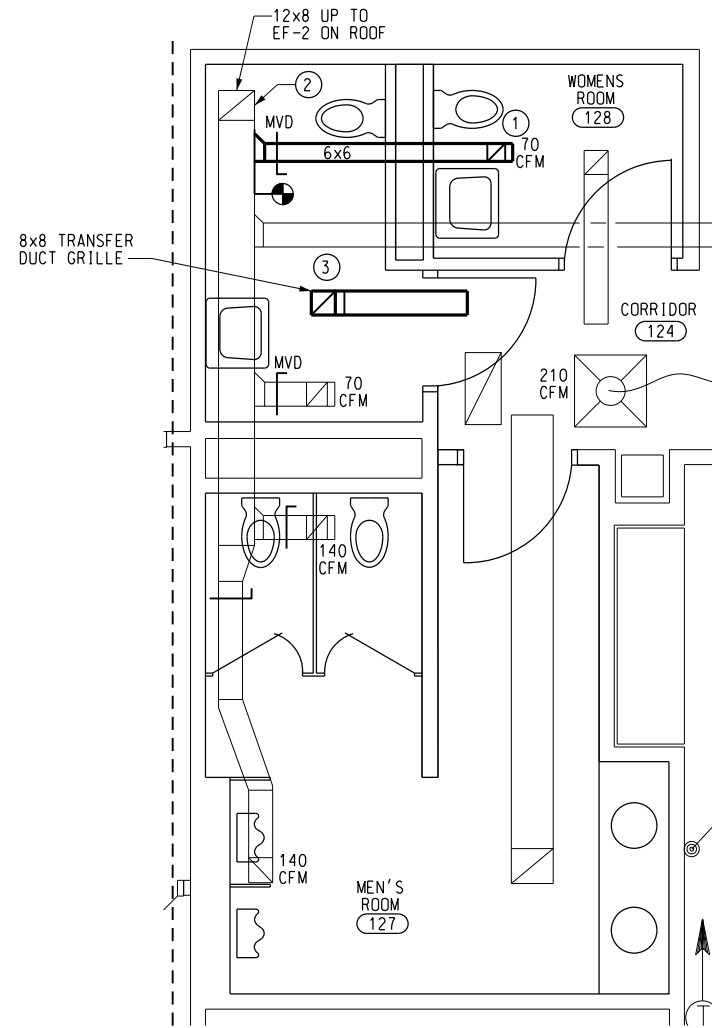

1 ENLARGED RESTROOM - HVAC PLAN  
 M400 SCALE: 3/8" = 1' - 0"



NOTES

- ① PROVIDE NEW RAG. MODEL BASIS OF DESIGN SHALL BE TITUS, 45F WITH A 6x6 NECK.
- ② SEE DETAIL 4/M600 FOR INSTALLATION OF EF-2.
- ③ PROVIDE NEW TRANSFER GRILLE. MODEL BASIS OF DESIGN SHALL BE TITUS, 45F WITH 8x8 NECK.

GENERAL

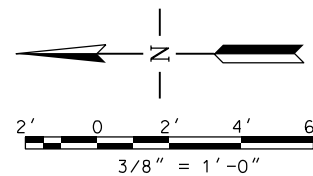
- A. NEW WORK IS SHOWN AS HEAVY LINE ON PLANS AND EXISTING WORK SHOWN IS LIGHT SOLID LINE.
- B. CONTRACTOR SHALL PERFORM AIR FLOW TEST AND REBALANCE ALL EXISTING AND NEW AIR DEVICES TO AIR FLOW INDICATED.
- C. WHERE NEW CONNECTION TO EXISTING IS INDICATED, THE CONTRACTOR SHALL FIELD VERIFY THE SIZE AND EXACT LOCATION OF THE EXISTING WORK AT THE POINT OF CONNECTION. NEW DUCT AND PIPE SIZE SHALL MATCH EXISTING.
- D. SEE DRAWING TRACO-M000 FOR HVAC LEGEND, GENERAL NOTES, AND SPECIAL NOTES.



SCALES SHOWN FOR 22" X 34" SHEET. ADJUST SCALES FOR OTHER SIZES.		PAGE	OF
			
 <b>WileyWilson</b> 5901 Peachtree Dunwoody Rd. Bldg. C, Ste 515 Atlanta, Georgia 30328-6055 678.320.1888 wileywilson.com WW JOB NUMBER: 219075.00			
DEPARTMENT OF TRANSPORTATION FEDERAL AVIATION ADMINISTRATION FORT LAUDERDALE AIRPORT TRAFFIC CONTROL TOWER MAJOR IMPROVEMENTS MECHANICAL ENLARGED RESTROOM HVAC PLAN FT LAUDERDALE (INTERNATIONAL) FL			
REV	APPROVED DATE	DESCRIPTION	JCN
			REVISION DATE
			APVD
REVIEWED BY		SUBMITTED BY	
DESIGNED		ISSUED BY	
DRAWN		ATLANTA TERMINAL ENGINEERING CENTER	
CHECKED		DATE	
SUBMITTER'S TITLE - CIVIL ENGINEER		APPROVER'S TITLE - MANAGER	
JJS		JCN	
CRK		JAN 31, 2020	
JJS		1508912	
		DRAWING NO	
		FLL-D-TRACO-M400	

**Will new AHU-1 fit on existing housekeeping pad?  
 Can pad be enlarged? Or does it need to be removed and replaced?**

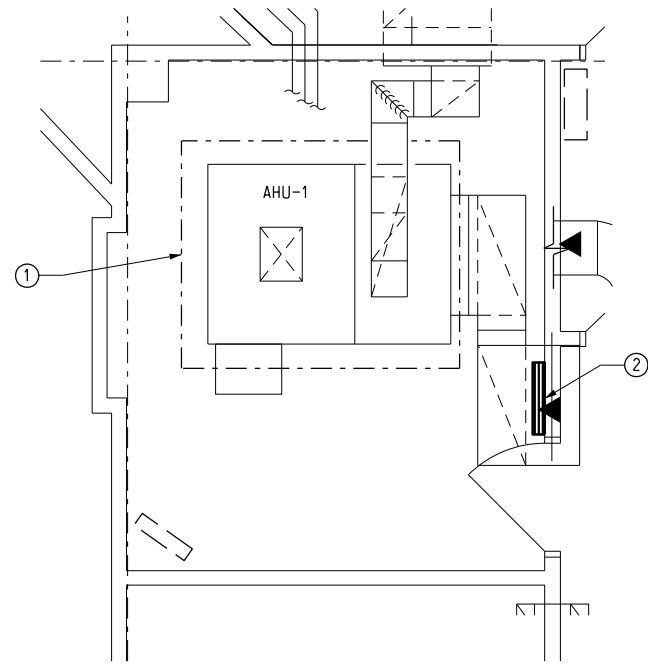

**1 ENLARGED MECHANICAL ROOM**  
 SCALE: 3/8" = 1' - 0"

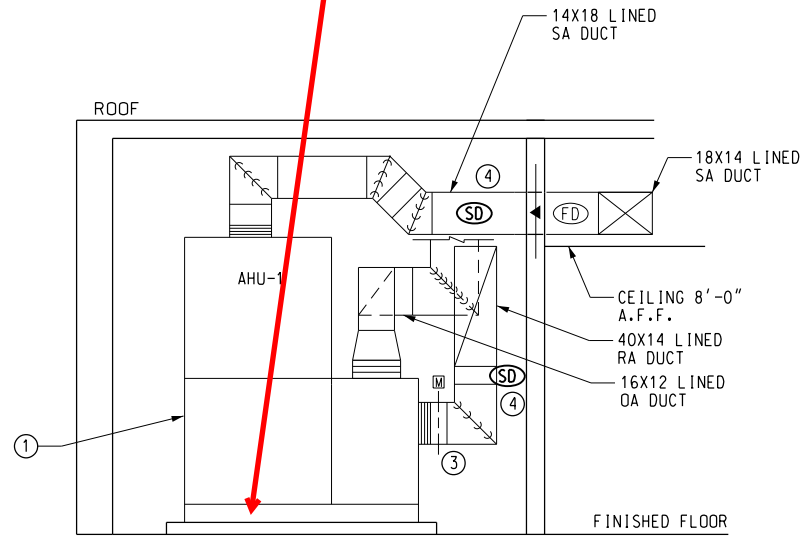

**2 AHU-1 SECTION**  
 SCALE: 3/8" = 1' - 0"

**NOTES**

- ① EXISTING AIR HANDLING UNIT TO REMAIN. INTEGRATE WITH NEW DDC SYSTEM.
- ② NEW DDC CONTROL PANEL.
- ③ PROVIDE NEW MOTOR OPERATED DAMPER (MOD) AND INTEGRATE WITH NEW DDC SYSTEM.
- ④ PROVIDE NEW DUCT-MOUNTED SMOKE DETECTORS, INTEGRATED WITH NEW DDC SYSTEM TO STOP AHU-1 SUPPLY FAN UPON DETECTION. COORDINATE WITH FIRE PROTECTION TO INTERLOCK TO FIRE ALARM CONTROL PANEL.

**GENERAL**

- A. NEW WORK IS SHOWN AS HEAVY LINE ON PLANS AND EXISTING WORK IS SHOWN LIGHT SOLID LINE.
- B. CONTRACTOR SHALL PERFORM AIR FLOW TEST AND REBALANCE ALL EXISTING AND NEW AIR DEVICES TO AIR FLOW INDICATED.
- D. WHERE NEW CONNECTION TO EXISTING IS INDICATED, THE CONTRACTOR SHALL FIELD VERIFY THE SIZE AND EXACT LOCATION OF THE EXISTING WORK AT THE POINT OF CONNECTION. NEW DUCT AND PIPE SIZE SHALL MATCH EXISTING.
- E. ALL NEW EXPOSED DUCTWORK SHALL BE INSULATED DOUBLE WALL DUCT AS PER SPECIFICATIONS, UNLESS OTHERWISE NOTED.
- F. SEE DRAWING TRACO-M000 FOR HVAC LEGEND, GENERAL NOTES, AND SPECIAL NOTES.
- G. WHERE FIRE OR FIRE/SMOKE DAMPERS ARE REMOVED IN CONJUNCTION WITH THIS WORK, THE REMOVED DAMPER SHALL BE REPLACED WITH THE SAME TYPE, RATING AND SHALL BE COORDINATED WITH THE FIRE ALARM AND ELECTRICAL CONTRACTORS.

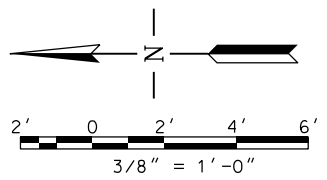

SCALES SHOWN FOR 22" X 34" SHEET. ADJUST SCALES FOR OTHER SIZES.		PAGE	OF
 <b>WileyWilson</b> 5901 Peachtree Dunwoody Rd. Bldg. C, Ste 515 Atlanta, Georgia 30328-6055 678.320.1888 wileywilson.com WW JOB NUMBER: 219075.00		DEPARTMENT OF TRANSPORTATION <b>FEDERAL AVIATION ADMINISTRATION</b>  FORT LAUDERDALE AIRPORT TRAFFIC CONTROL TOWER MAJOR IMPROVEMENTS MECHANICAL <b>ENLARGED MECHANICAL ROOM &amp; SECTION</b> FT LAUDERDALE (INTERNATIONAL) FL	
REV	APPROVED DATE	DESCRIPTION	JCN
			REVISION DATE
REVIEWED BY		SUBMITTED BY	
DESIGNED		ISSUED BY	
DRAWN		ATLANTA TERMINAL ENGINEERING CENTER	
CHECKED		DATE JAN 31, 2020	
		JCN 1508912	
		DRAWING NO	
		FLL-D-TRACO-M420	

EXISTING AIR HANDLING UNIT SCHEDULE SEE NOTES (18)(19)

MARK	LOCATION	TYPE	SUPPLY AIR (CFM)	OUTSIDE AIR (CFM)	E.S.P. (IN. WG.)	T.S.P. (IN. WG.)	MOTOR HP	FAN RPM	TOTAL COOLING CAP. (MBH)	SENSIBLE COOLING CAP. (MBH)	EAT (°F)		LAT (°F)		COIL APD (IN WG)	VOLTAGE/PHASE/Hz	BASIS OF DESIGN	REMARKS
											DB	WB	DB	WB				
AHU-1	BASE BUILDING MECHANICAL ROOM	SPLIT-DX	4200	1440	3.5	5.86	7.5	2535	274	179	85	69	46.1	46.1	1.39	208/3/60	YORK - XT1-42x60	(1)(2)(3)(4)(6)(7)(8)(9)(10)(11)(12)(13)(14)(15)(16)

EXISTING AIR COOLED CONDENSING UNIT SCHEDULE SEE NOTE (18)

MARK	LOCATION	SERVES	COOLING CAPACITY (TONS)	MIN. NO. REFRIG. CIRCUITS	MINIMUM SEER	COMPRESSOR DATA				CONDENSER DATA		UNIT AMPACITY	ELECTRIC DATA				MAKE AND MODEL	REMARKS
						QTY.	REFRIG. TYPE	NO. OF STEPS	SATB SUCT. TEMP (°F)	COND. FANS QTY.	AMBIENT TEMP °F	AMPS	VOLTS	PH	HZ			
CU-1	380	BASE BUILDING	30	2	9.7	4	R-410A	2	40	4	95	129.5	208	3	60	YORK-J30YD	(1)(2)(3)(4)(5)(6)(8)(13)(15)(17)	

NOTES ARE FOR AHU AND CU

- (1) MAINTAIN MANUFACTURER'S RECOMMEND CLEARANCES FOR SERVICE AND AIRFLOW.
- (2) SPLIT SYSTEM SUBMITTAL SHALL INCLUDE DATA ON LINESET LENGTH LIMITATIONS AND DE-RATING VALUES THEREIN.
- (3) SELECTIONS SHALL BE BASED ON CAPACITIES AND NOT NOMINAL TONNAGES LISTED FOR REFERENCE ONLY.
- (4) COOLING CAPACITIES BASED ON 95 DEGREE AMBIENT AIR TEMPERATURE, 85 DEGREES DB/EAT, AND 69 DEGREES WB EAT.
- (5) HEAT PUMP SHALL BE PROVIDED WITH NECESSARY KIT AND ACCESSORIES FOR LOW -AMBIENT COOLING OPERATION.
- (6) MOUNT INDOOR UNIT PER FEMA SEISMIC REQUIREMENTS.
- (7) PROVIDE FIELD-POWERED CONVENIENCE OUTLET AT THE CONDENSING UNIT.
- (8) PROVIDE SMOKE DETECTOR IN AHU SUPPLY AND RETURN DUCTS. SMOKE DETECTORS SHALL BE INTERLOCKED TO FIRE PROTECTION CONTROLS. CONTRACTOR SHALL PROVIDE AND COORDINATE WITH FIRE PROTECTION CONTRACTOR.
- (9) PROVIDE WITH THERMOSTAT/HUMIDISTAT TO BE INTERLOCKED WITH DDC SYSTEM. MOUNT THERMOSTAT MIN. 48" AFF. THERMOSTAT/HUMIDISTAT SHALL BE PASSWORD PROTECTED OR TAMPER-PROOF. SEE CONTROLS DRAWINGS FOR SETTINGS.
- (10) PROVIDE THERMOSTATIC EXPANSION VALVE.
- (11) PROVIDE WITH CONDENSATE OVERFLOW SWITCH. SWITCH SHALL SHUT DOWN UNIT AND INDICATE ALARM IN DDC. SEE CONTROL DRAWINGS.
- (12) PROVIDE WITH CONDENSATE PUMP CAPABLE OF 10 FT. HD AND 25 GPH, BOD: LITTLE GIANT VCMA-15UL.
- (13) PROVIDE SECONDARY CORROSION RESISTANT DRAIN PAN.
- (14) SHOP DRAWINGS SHALL INCLUDE COMBINATION RATINGS.
- (15) PROVIDE (MODINE ELECTROFIN E-COAT) ON CONDENSER AND EVAPORATOR COILS.
- (16) UNIT SHALL BE DIRECT DRIVE WITH INTEGRAL VFD.
- (17) SEE ELECTRICAL FOR DISCONNECT AT CU-1.
- (18) REPLACEMENT OF AHU-1 & CU-1 ARE BEING COMPLETED UNDER A SEPARATE CONTRACT AND ARE NOT A PART OF THE SCOPE OF THIS PROJECT. DATA IS PROVIDED FOR REFERENCE ONLY.
- (19) PROVIDE NEW DUCT MOUNTED SMOKE DETECTORS IN SUPPLY AND RETURN DUCTS. SEE NOTE 8 FOR ADDITIONAL INFORMATION.

VARIABLE AIR VOLUME TERMINAL BOX SCHEDULE

MARK	COOLING		MAX. DISCHARGE (SP IN. WG.)	INLET SIZE (IN)	HEATING (MIN. CFM)	ELECTRIC REHEAT (KW)	"STAGES"	EAT (°F)	LAT (°F)	VOLT/PH/Hz/STAGES	TITUS MODEL	REMARKS
	(MAX. CFM)	(MIN. CFM)										
VAV-1	510	170	0.5	7	170	2.5	2	48	95	208/1/60/1	DESV-7	(1)(2)(3)(4)(5)(6)
VAV-2	230	135	0.5	5	135	2	1	48	95	208/1/60/1	DESV-5	(1)(2)(3)(4)(5)(6)
VAV-3	855	405	0.5	8	405	6	2	48	95	208/1/60/1	DESV-8	(1)(2)(3)(4)(5)(6)
VAV-4	385	135	0.5	5	135	2	2	48	95	208/1/60/1	DESV-5	(1)(2)(3)(4)(5)(6)
VAV-5	500	270	0.5	7	270	4	1	48	95	208/1/60/1	DESV-7	(1)(2)(3)(4)(5)(6)
VAV-6	260	135	0.5	5	135	2	2	48	95	208/1/60/1	DESV-5	(1)(2)(3)(4)(5)(6)
VAV-7	515	170	0.5	5	170	2.5	1	48	95	208/1/60/1	DESV-5	(1)(2)(3)(4)(5)(6)
VAV-8	1080	605	0.5	10	605	9.0	2	48	95	208/1/60/1	DESV-10	(1)(2)(3)(4)(5)(6)
VAV-9	200	135	0.5	5	135	2	2	48	95	208/1/60/1	DESV-5	(1)(2)(3)(4)(5)(6)

- (1) PROVIDE WITH FACTORY MOUNTED DDC CONTROLLERS (DDC SUPPLIED BY THE CONTROLS MANUFACTURER AND MOUNTED BY THE TERMINAL UNIT MANUFACTURER).
- (2) PROVIDE DOUBLE-WALL CONSTRUCTION AND ACCESS PANEL.
- (3) MAXIMUM NC LEVEL SHALL BE NC 30.
- (4) HEATING CFM IS BASED ON 47-DEGREE DELTA T AND AN LAT OF 95 DEGREES.
- (5) PROVIDE DIGITAL-BASED MOTOR-OPERATED VALVE.
- (6) PROVIDE WITH INTERNAL NON-FUSED, DOOR INTERLOCK DISCONNECT. COORDINATE WITH ELECTRICAL.

EXHAUST FAN SCHEDULE

MARK	LOCATION	SERVES	TYPE	CFM	ESP INCH WG	FAN RPM	MAX SONES	MOTOR DATA					DRIVE	BASIS OF DESIGN (GREENHECK)	REMARKS
								HP	RPM	VOLT	PH	HZ			
EF-2	BASE BUILDING	TOILETS	ROOF CENTRIFUGAL	420	0.325	1203	5.8	1/6	1725	115	1	60	DIRECT	G-095-VG	(1)(2)(3)

- (1) PROVIDE WITH FACTORY ROOF CURB, BACKDRAFT DAMPER, BIRD SCREEN AND DISCONNECT SWITCH.
- (2) FAN AND CURB SHALL BE CERTIFIED MIAMI-DADE HIGH WIND RATED.
- (3) PROVIDE CORROSION PROTECTION ON ALL METAL COMPONENTS INCLUDING HOUSING, WHEEL, THROAT, BACKDRAFT DAMPER AND CURB. CORROSION PROTECTION SHALL BE FACTORY COATING OF ELECTROSTATICALLY APPLIED POWDERED POLYESTER-URETHANE.

FIRE AND SMOKE DAMPER SCHEDULE

MARK	LOCATION	NORMAL SETTING	FUNCTION	TYPE
FSD-1	BASE BUILDING/LINK	NO	SA, FSD	2 POSITION, LL, FL, PB, M
FSD-2	BASE BUILDING/LINK	NO	SA, FSD	2 POSITION, LL, FL, PB, M

- SA = SUPPLY AIR DUCT
- NO = NORMALLY OPEN
- RA = RETURN AIR DUCT
- FL = FUSIBLE LINK
- M = MOTORIZED
- FSD = COMBINATION FIRE AND SMOKE DAMPER
- LL = LOW LEAKAGE, AIRFOIL BLADE
- PB = PARALLEL BLADE

SCALES SHOWN FOR 22" X 34" SHEET. ADJUST SCALES FOR OTHER SIZES. PAGE OF



**WileyWilson**  
5901 Peachtree Dunwoody Rd.  
Bldg. C, Ste 515  
Atlanta, Georgia 30328-6055  
678.320.1888  
wileywilson.com  
WW JOB NUMBER: 219075.00

REV	APPROVED DATE	DESCRIPTION	JCN	REDLINE DATE	APVD

**DEPARTMENT OF TRANSPORTATION  
FEDERAL AVIATION ADMINISTRATION**

**FORT LAUDERDALE AIRPORT TRAFFIC CONTROL TOWER  
MAJOR IMPROVEMENTS  
MECHANICAL  
HVAC SCHEDULES**

FT LAUDERDALE (INTERNATIONAL) FL

DESIGNED	JUS	ISSUED BY	DATE	JAN 31, 2020	JCN	1508912
DRAWN	CRK	ATLANTA TERMINAL ENGINEERING CENTER	DRAWING NO	FLL-D-TRACO-M500		
CHECKED	JUS					

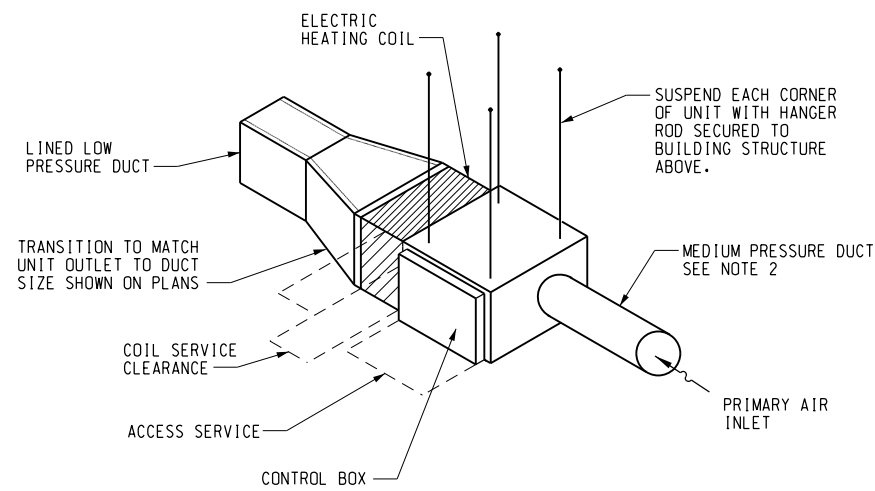

**NOTES:**

1. VERIFY AND PROVIDE ACCESS SPACE, COIL AND CONTROL BOX LOCATIONS WITH SELECTED MANUFACTURER.
2. MINIMUM 3 DIAMETERS OF STRAIGHT-RUN DUCTWORK TO THE INLET CONNECTION. THE STRAIGHT-RUN DUCTWORK SHALL BE THE SAME DIAMETER AS THE AIR VALVE INLET CONNECTION AS INDICATED ON THE EQUIPMENT SCHEDULE.

**1** VARIABLE AIR VOLUME TERMINAL UNIT DETAIL  
M600 NOT TO SCALE

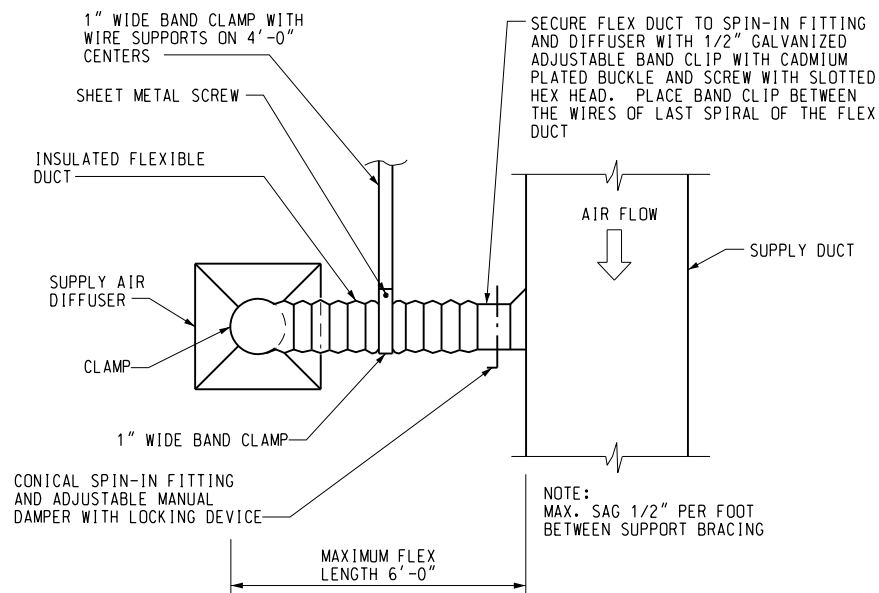

NOTE:  
MAX. SAG 1/2" PER FOOT  
BETWEEN SUPPORT BRACING

**2** DIFFUSER CONNECTION DETAIL  
M600 NOT TO SCALE

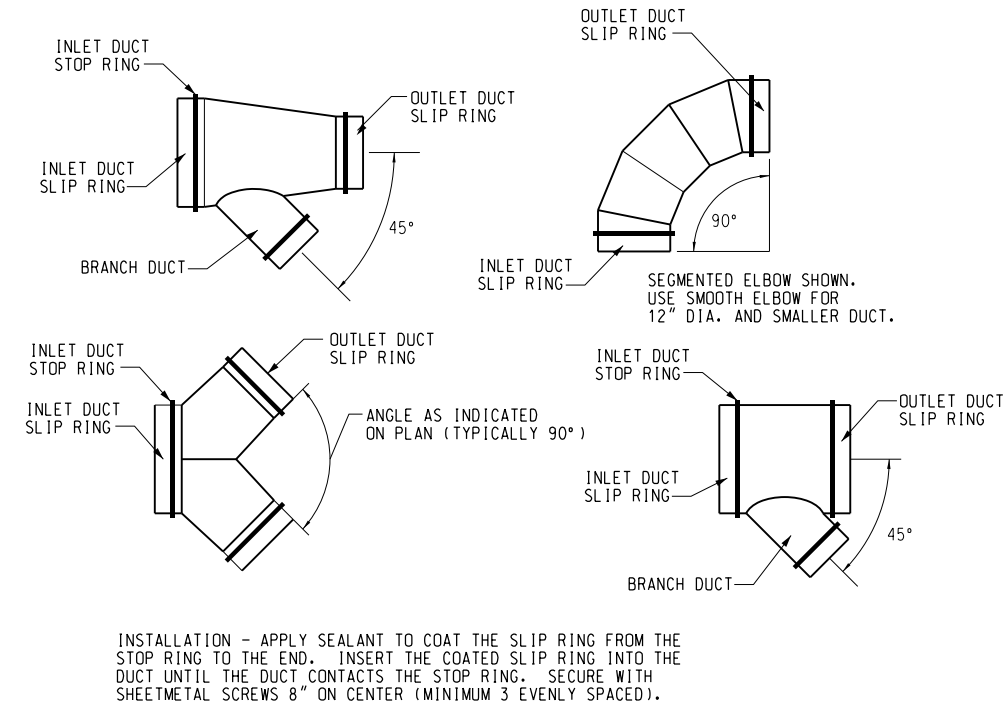

INSTALLATION - APPLY SEALANT TO COAT THE SLIP RING FROM THE STOP RING TO THE END. INSERT THE COATED SLIP RING INTO THE DUCT UNTIL THE DUCT CONTACTS THE STOP RING. SECURE WITH SHEETMETAL SCREWS 8" ON CENTER (MINIMUM 3 EVENLY SPACED).

**3** MEDIUM PRESSURE DUCT DETAIL  
M600 NOT TO SCALE

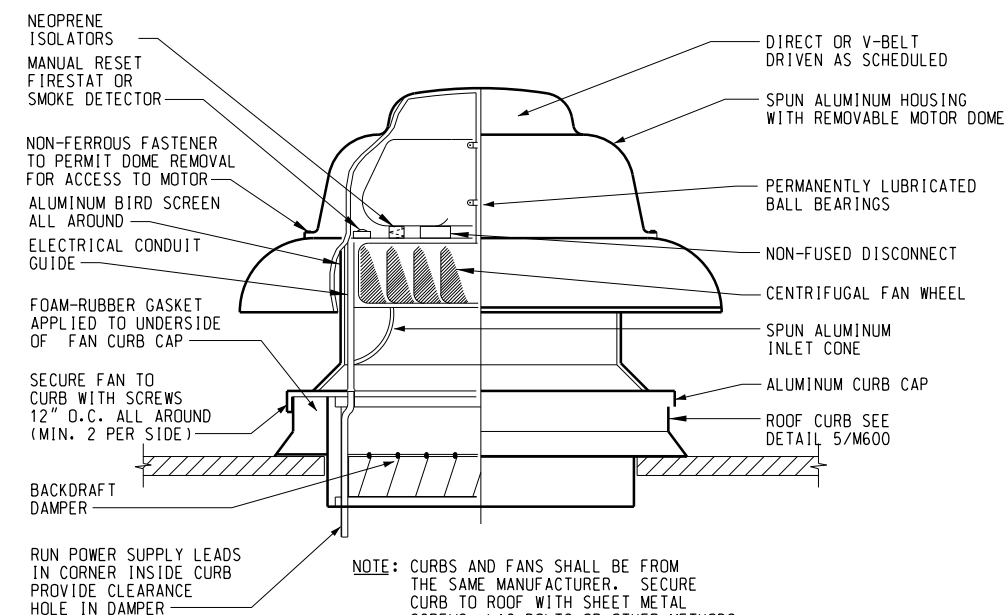

NOTE: CURBS AND FANS SHALL BE FROM THE SAME MANUFACTURER. SECURE CURB TO ROOF WITH SHEET METAL SCREWS, LAG BOLTS OR OTHER METHODS CONSISTENT WITH ROOF CONSTRUCTION.

**4** ROOF-MOUNTED CENTRIFUGAL EXHAUST FAN DETAIL  
M600 NOT TO SCALE

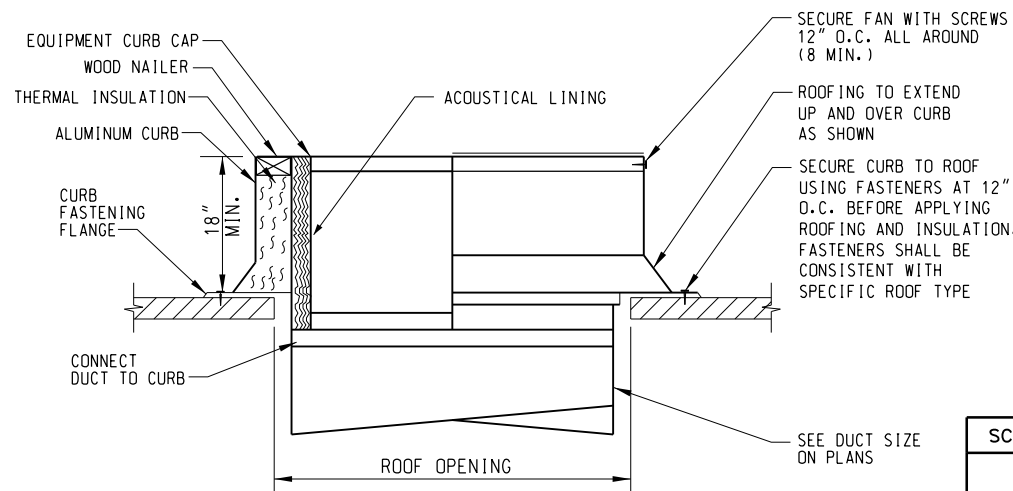

NOTE:  
CONTRACTOR SHALL COORDINATE THE PLACEMENT OF THE NEW ROOF CURB WITH THE EXISTING ROOF OPENING FROM THE REMOVED EXISTING EXHAUST FAN TO AVOID CONFLICTS WITH DUCTWORK BELOW.

**5** ROOF CURB DETAIL  
M600 NOT TO SCALE

SCALES SHOWN FOR 22" X 34" SHEET. ADJUST SCALES FOR OTHER SIZES. PAGE OF

REV	APPROVED DATE	DESCRIPTION	JCN	REDLINE DATE	APVD
DEPARTMENT OF TRANSPORTATION <b>FEDERAL AVIATION ADMINISTRATION</b>  FORT LAUDERDALE AIRPORT TRAFFIC CONTROL TOWER MAJOR IMPROVEMENTS MECHANICAL HVAC DETAILS  FT LAUDERDALE (INTERNATIONAL) FL					
REVIEWED BY DESIGNED JJS DRAWN CRK CHECKED JJS		SUBMITTED BY SUBMITTER'S TITLE - CIVIL ENGINEER ISSUED BY ATLANTA TERMINAL ENGINEERING CENTER		APPROVED BY APPROVER'S TITLE - MANAGER DATE JAN 31, 2020 JCN 1508912 DRAWING NO. FLL-D-TRACO-M600 REV	

**WileyWilson**  
5901 Peachtree Dunwoody Rd.  
Bldg. C, Ste 515  
Atlanta, Georgia 30328-6055  
678.320.1888  
wileywilson.com  
WW JOB NUMBER: 219075.00

What equipment sits on this? Where is it located?

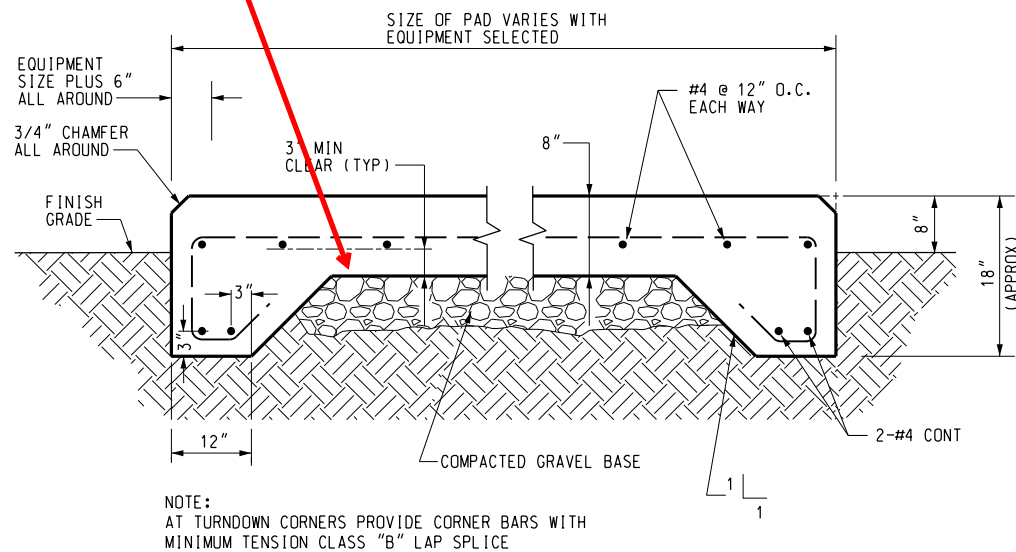

**1** EXTERIOR CONCRETE EQUIPMENT PAD DETAIL  
M601 NOT TO SCALE

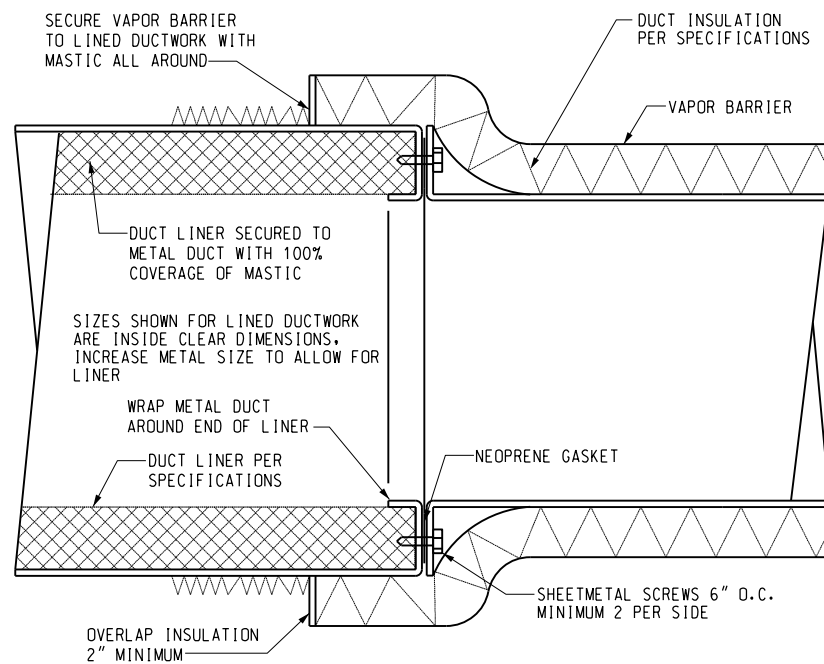

**2** DUCT LINER TERMINATION DETAIL  
M601 NOT TO SCALE

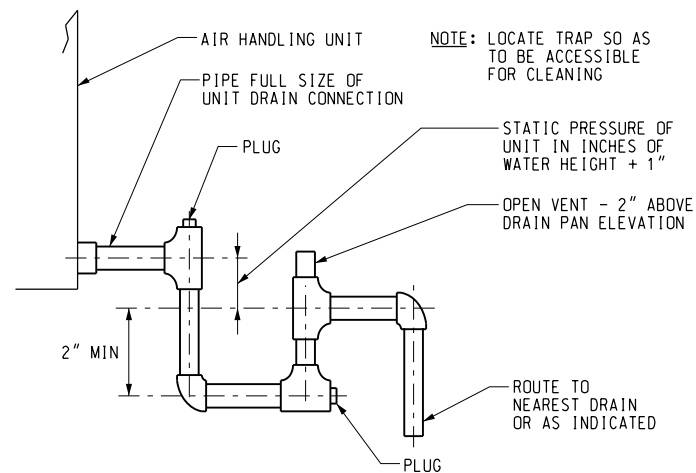

**3** CONDENSATE TRAP DETAIL  
M601 NOT TO SCALE

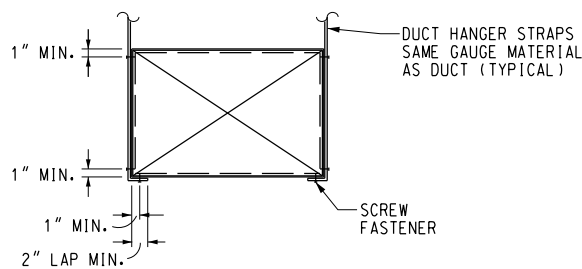

NOTE:  
ALL DUCTWORK TO BE SUPPORTED PER LATEST EDITION OF  
"SMACNA HVAC DUCT CONSTRUCTION STANDARDS"

**4** DUCT HANGER DETAIL  
M601 NOT TO SCALE

SCALES SHOWN FOR 22" X 34" SHEET. ADJUST SCALES FOR OTHER SIZES. PAGE OF

REV	APPROVED DATE	DESCRIPTION	JCN	REDLINE DATE	APVD

DEPARTMENT OF TRANSPORTATION  
FEDERAL AVIATION ADMINISTRATION

FORT LAUDERDALE AIRPORT TRAFFIC CONTROL TOWER  
MAJOR IMPROVEMENTS  
MECHANICAL  
HVAC DETAILS

FT LAUDERDALE (INTERNATIONAL) FL

WileyWilson  
5901 Peachtree Dunwoody Rd.  
Bldg. C, Ste 515  
Atlanta, Georgia 30328-6055  
678.320.1888  
wileywilson.com  
WW JOB NUMBER: 219075.00

REVIEWED BY	SUBMITTED BY	APPROVED BY
DESIGNED	ISSUED BY	APPROVER'S TITLE - MANAGER
DRAWN	ATLANTA TERMINAL ENGINEERING CENTER	DATE JAN 31, 2020 JCN 1508912
CHECKED		DRAWING NO. FLL-D-TRACO-M601 REV

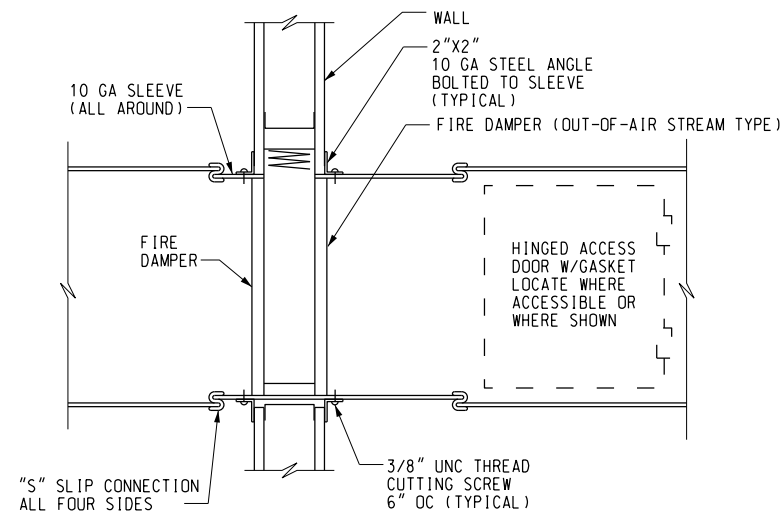

NOTE:  
SIDE ELEVATION SHOWN. PROVIDE CLEARANCES AS SPECIFIED IN SMACNA  
"FIRE DAMPER AND HEAT STOP GUIDE FOR AIR HANDLING SYSTEMS".

**1 FIRE DAMPER DETAIL**  
M602 NOT TO SCALE

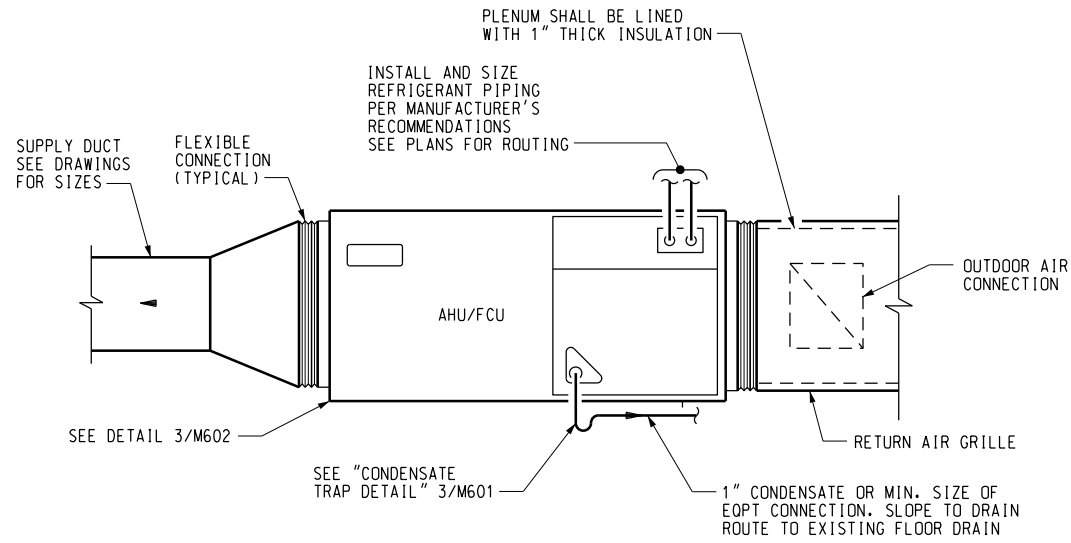

NOTE:  
SUSPENDED AHU'S AND DRAIN PANS FROM STRUCTURE ABOVE.  
INSTALL PER MANUFACTURER'S RECOMMENDATIONS.

**2 TYPICAL HORIZONTAL AHU/FCU DETAIL**  
M602 NOT TO SCALE

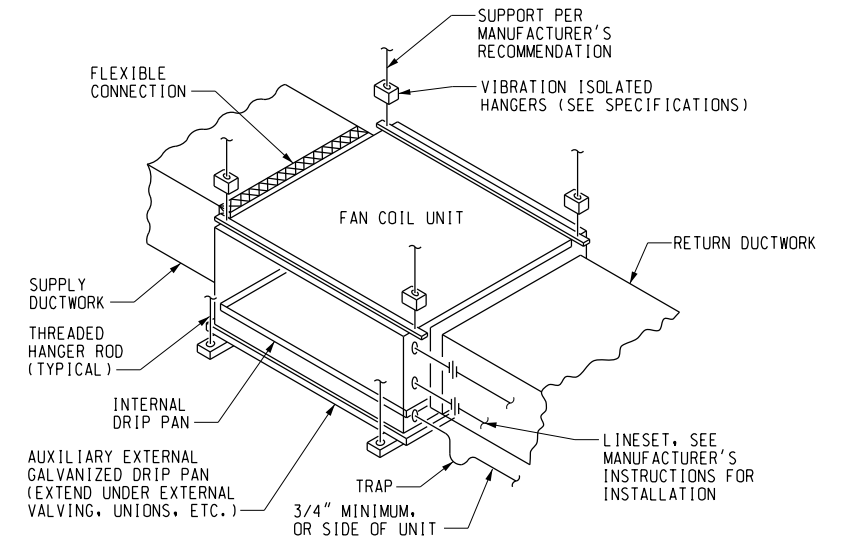

**3 FAN COIL UNIT SUPPORT DETAIL**  
M602 NOT TO SCALE

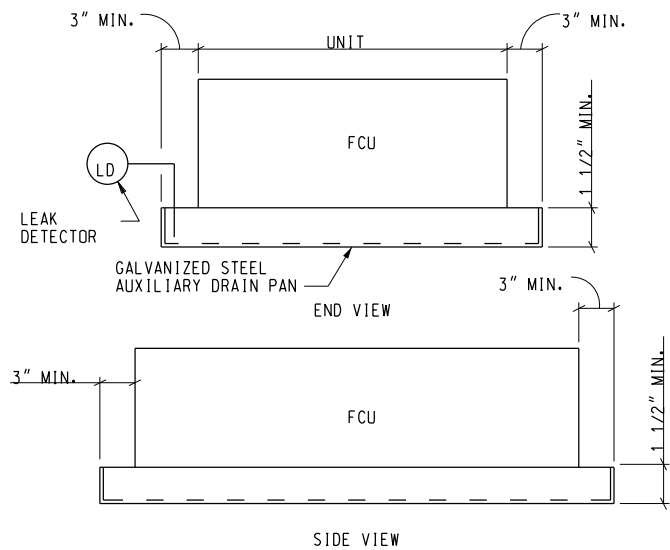

NOTE:  
THE SYSTEM SHALL BE DE-ENERGIZED AT THE  
DETECTION OF LIQUID IN THE DRAIN PAN.

**4 DRAIN PAN DETAIL**  
M602 NOT TO SCALE

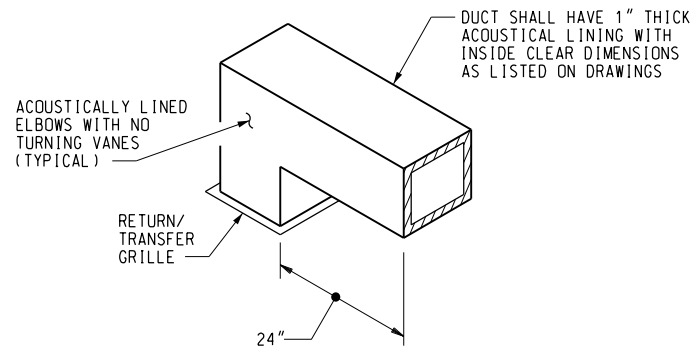

**5 RETURN GRILLE DUCT DETAIL**  
M602 NOT TO SCALE

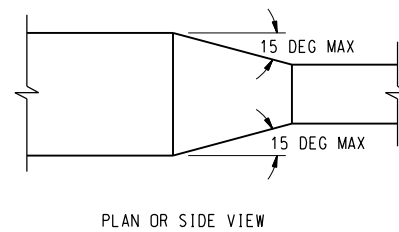

**6 TYPICAL DUCTWORK TRANSITION DETAIL**  
M602 NOT TO SCALE

SCALES SHOWN FOR 22" X 34" SHEET. ADJUST SCALES FOR OTHER SIZES. PAGE OF

REV	APPROVED DATE	DESCRIPTION	JCN	REDLINE DATE	APVD
DEPARTMENT OF TRANSPORTATION <b>FEDERAL AVIATION ADMINISTRATION</b>  <b>FORT LAUDERDALE AIRPORT TRAFFIC CONTROL TOWER          MAJOR IMPROVEMENTS          MECHANICAL          DETAILS</b>  FT LAUDERDALE (INTERNATIONAL) FL					
 <b>WileyWilson</b> 5901 Peachtree Dunwoody Rd. Bldg. C, Ste 515 Atlanta, Georgia 30328-6055 678.320.1888 wileywilson.com WW JOB NUMBER: 219075.00		REVIEWED BY  SUBMITTED BY  APPROVED BY  SUBMITTER'S TITLE - CIVIL ENGINEER DESIGNED JJS ISSUED BY DRAWN CRK ATLANTA TERMINAL CHECKED JJS ENGINEERING CENTER	DATE JAN 31, 2020 JCN 1508912 DRAWING NO <b>FLL-D-TRACO-M602</b>	APPROVER'S TITLE - MANAGER	REV

**NOTES**

1. SEE DRAWING TRACO-M000 FOR HVAC LEGEND AND GENERAL NOTES.
2. EXISTING AIR HANDLING UNIT TO REMAIN. INTEGRATE WITH NEW DDC SYSTEM.
3. THE SMOKE DETECTOR AND FIRE ALARM CONTROL MODULES SHALL BE FURNISHED AND INSTALLED BY FIRE ALARM CONTRACTOR.
4. INSTRUMENT NUMBER ASSIGNMENTS ARE OMITTED WHEN DIAGRAMS APPLY TO MULTIPLE SYSTEMS/ EQUIPMENT. CONTRACTOR SHALL ASSIGN THEM.

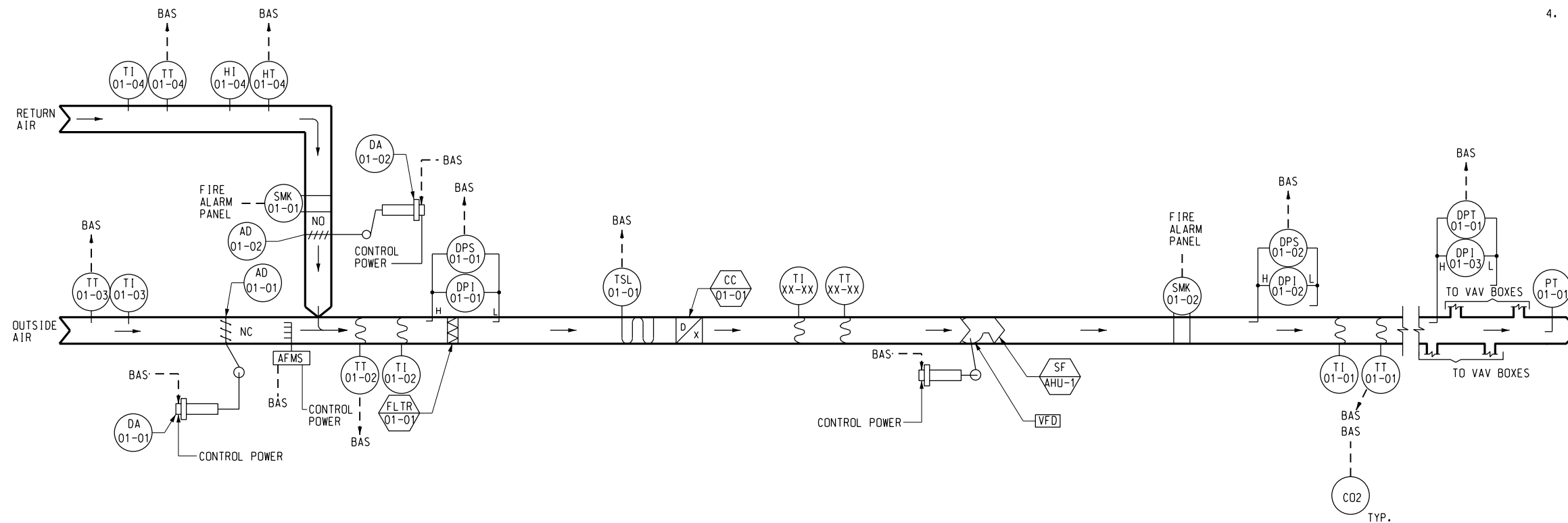

**1 CONTROL SYSTEM DIAGRAM - AHU-1**  
M800 NOT TO SCALE

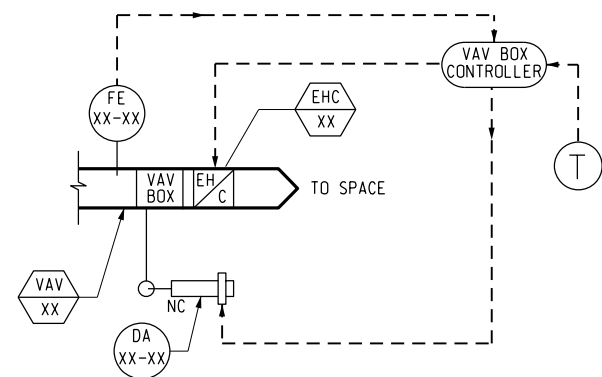

**2 CONTROL DIAGRAM - TERMINAL UNIT (VAV)**  
M800 NOT TO SCALE (VAV-1 THRU VAV-9)

EXISTING EXHAUST FANS AS FOLLOWS:  
 - ONE ROOF MOUNTED TYPE IN BASE BUILDING (TOILETS AND JANITOR).  
 - ONE INLINE CENTRIFUGAL TYPE ON JUNCTION LEVEL IN TOWER (TOILET)

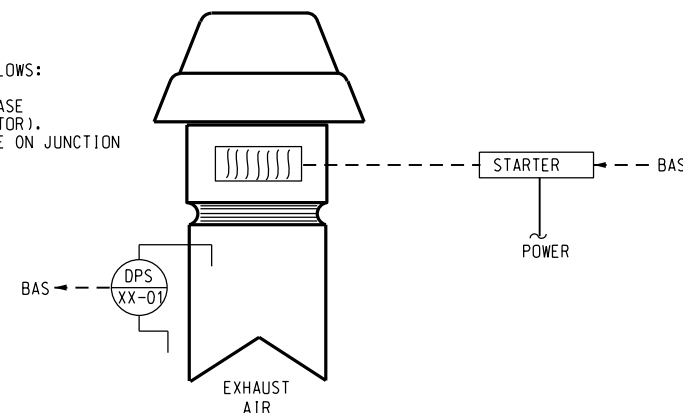

**3 CONTROL DIAGRAM - EXHAUST FANS**  
M800 NOT TO SCALE

SCALES SHOWN FOR 22" X 34" SHEET. ADJUST SCALES FOR OTHER SIZES.				1	OF
REV	APPROVED DATE	DESCRIPTION	JCN	REDLINE DATE	APVD
DEPARTMENT OF TRANSPORTATION FEDERAL AVIATION ADMINISTRATION					
FORT LAUDERDALE AIRPORT TRAFFIC CONTROL TOWER MAJOR IMPROVEMENTS MECHANICAL CONTROL SYSTEM DIAGRAM AHU-1, VAV & EXHAUST FANS					
FT LAUDERDALE		(INTERNATIONAL)		FL	
REVIEWED BY	SUBMITTED BY	APPROVED BY			
DESIGNED	JJS	SUBMITTER'S TITLE - CIVIL ENGINEER		APPROVER'S TITLE - MANAGER	
DRAWN	CRK	ISSUED BY		DATE JAN 31, 2020 JCN 1508912	
CHECKED	JJS	ATLANTA TERMINAL ENGINEERING CENTER		DRAWING NO. FLL-D-TRACO-M800	
WILEY WILSON 5901 Peachtree Dunwoody Rd. Bldg. C, Ste 515 Atlanta, Georgia 30328-6055 678.320.1888 wileywilson.com WW JOB NUMBER: 219075.00					

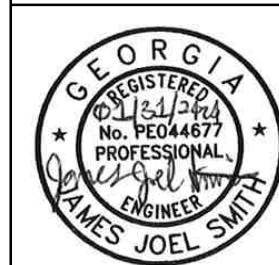



NOTES

1. SEE DRAWING TRACO-M000 FOR HVAC LEGEND AND GENERAL NOTES.
2. THE SMOKE DETECTOR AND FIRE ALARM CONTROL MODULES SHALL BE FURNISHED AND INSTALLED BY FIRE ALARM CONTRACTOR.
3. INSTRUMENT NUMBER ASSIGNMENTS ARE OMITTED WHEN DIAGRAMS APPLY TO MULTIPLE SYSTEMS/ EQUIPMENT. CONTRACTOR SHALL ASSIGN THEM.

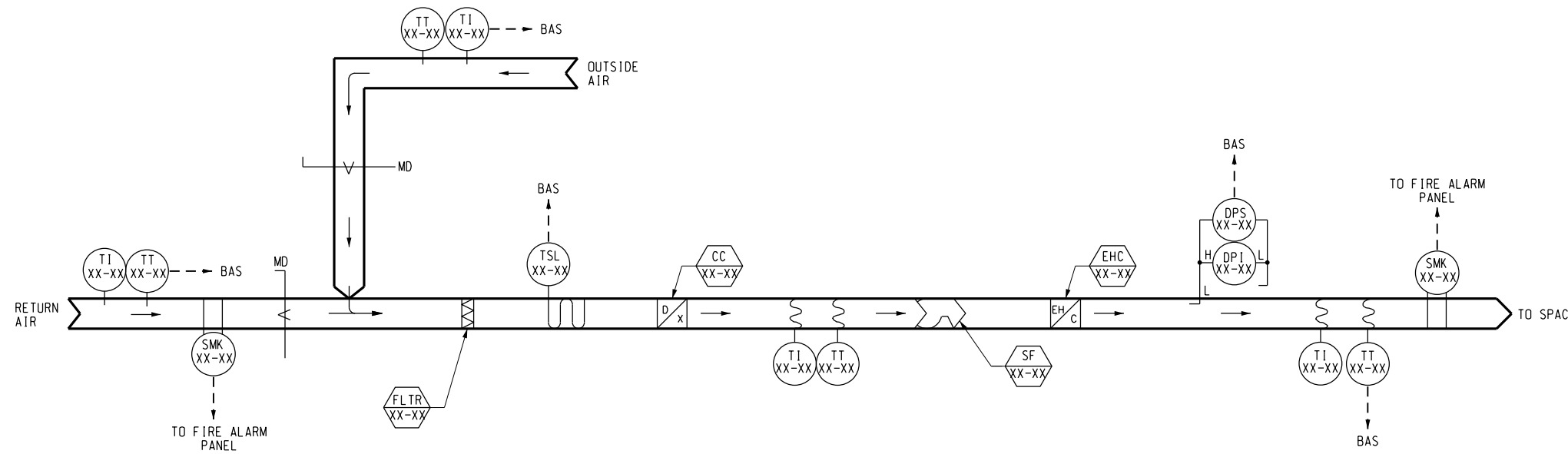

1 CONTROL SYSTEM DIAGRAM - FCU-1 AND FCU-2  
M801 NOT TO SCALE

SCALES SHOWN FOR 22" X 34" SHEET. ADJUST SCALES FOR OTHER SIZES.		PAGE	OF
			
DEPARTMENT OF TRANSPORTATION FEDERAL AVIATION ADMINISTRATION			
FORT LAUDERDALE AIRPORT TRAFFIC CONTROL TOWER MAJOR IMPROVEMENTS MECHANICAL CONTROL SYSTEM DIAGRAM FCU-1 AND FCU-2			
FT LAUDERDALE		(INTERNATIONAL)	FL
REVIEWED BY	SUBMITTED BY	APPROVED BY	
SUBMITTER'S TITLE - CIVIL ENGINEER		APPROVER'S TITLE - MANAGER	
DESIGNED	JJS	ISSUED BY	DATE JAN 31, 2020 JCN 1508912
DRAWN	CRK	ATLANTA TERMINAL ENGINEERING CENTER	DRAWING NO
CHECKED	JJS		FLL-D-TRACO-M801
WileyWilson 5901 Peachtree Dunwoody Rd. Bldg. C, Ste 515 Atlanta, Georgia 30328-6055 678.320.1888 wileywilson.com WW JOB NUMBER: 219075.00			

**GENERAL**

- THE NEW HVAC CONTROL SYSTEM AND ASSOCIATED SHALL BE DIRECT DIGITAL CONTROL (DDC) SYSTEM, "SMARTSTRUXURE" AS MANUFACTURED BY SCHNEIDER ELECTRIC.
- NEW THERMOSTATS SHALL BE SCHNEIDER ELECTRIC STR 250, WALL-MOUNTED ALPHANUMERIC DISPLAY WITH ADJUSTABLE DDC DETERMINED BAND.
- PROVIDE A NEW DDC CENTRAL WORKSTATION WHERE DIRECTED BY THE FAA CONTRACTING OFFICER REPRESENTATIVE.

**SEQUENCE OF OPERATION: AHU-1 AND CU-1**

- AHU-1 SHALL BE CONTROLLED BY A PROCESS CONTROL UNIT. THE SYSTEM SUPPLY FAN SHALL START UPON A SIGNAL FROM THE DDC CONTROL PANEL WHICH SHALL HAVE PROGRAMMABLE OCCUPIED AND UNOCCUPIED TIMES WITH A MANUAL OVERRIDE FOR HOLIDAY PERIODS, ETC.
- THE SYSTEM SHALL "SOFT START" THE SUPPLY FAN AND SLOWLY RAMP THE VARIABLE FREQUENCY DRIVE UP TO CONTROL THE STATIC PRESSURE IN THE SUPPLY DUCT MONITORED 2/3 OF THE DISTANCE DOWN THE LONGEST DUCT.
- THE SYSTEM SHALL MAINTAIN A CONSTANT MINIMUM OUTSIDE AIR FLOW (ADJUSTABLE) BY MONITORING A DUCT-MOUNTED AIR FLOW MEASURING STATION AND MODULATION OF THE AHU MIXING BOX DAMPERS. THE SUPPLY AIR TEMPERATURE SETPOINT (ADJUSTABLE) SHALL BE MAINTAINED BY CONTROL OF THE MULTI-STAGE CONDENSING UNIT.
- THE DDC SYSTEM SHALL MONITOR TWO SPACE MOUNTED CO2 SENSORS. IF THE SPACE CO2 EXCEEDS THE CO2 SETPOINT (ADJUSTABLE) THE SYSTEM SHALL INCREASE THE FRESH AIR INTAKE THROUGH MODULATION OF THE AHU MIXING BOX DAMPERS.
- SMOKE DETECTORS IN THE SUPPLY AIR AND RETURN AIR DUCTWORK SHALL STOP THE SUPPLY FAN AND INITIATE A SMOKE ALARM IF SMOKE IS DETECTED AT EITHER LOCATION. RESTARTING THE SUPPLY FAN SHALL REQUIRE MANUAL RESET AT THE SMOKE DETECTORS.
- SUPPLY AIR TEMPERATURE RESET:  
THE NORMAL SUPPLY AIR TEMPERATURE SHALL BE 55 DEGREES F (ADJUSTABLE). WHEN THE TEMPERATURE IN ANY SPACE REMAINS ABOVE SETPOINT FOR 10 MINUTES (ADJUSTABLE) AS MEASURED BY THE SPACE TEMPERATURE SENSOR WITH THE VAV DAMPER AT ITS MAXIMUM POSITION THE SUPPLY AIR TEMPERATURE SHALL BE RESET TO LOW TEMPERATURE SETTING (46 DEGREES F, ADJUSTABLE). SUPPLY AIR TEMPERATURE SHALL REMAIN AT LOW SETTING UNTIL ALL ZONES HAVE FALLEN BELOW COOLING SETPOINT. WHEN ALL ZONES ARE SATISFIED FOR COOLING THE SAT SHALL REVERT BACK TO ITS NORMAL 55 DEGREES F (ADJUSTABLE) TEMPERATURE.
- HUMIDITY CONTROL SEQUENCE:  
IF THE BUILDING HUMIDITY LEVELS RISE ABOVE SETPOINTS (ADJUSTABLE) AS SENSED BY THE RETURN AIR DUCT SENSOR, THE OA DAMPER SHALL MOVE TO ITS MINIMUM SCHEDULED POSITION AND THE RETURN AIR DAMPER SHALL OPEN FULLY. THIS MODE SHALL CONTINUE UNTIL SUCH TIME AS THE HUMIDITY FALLS BELOW THE SETPOINT. IF BUILDING HUMIDITY REMAINS ABOVE SETPOINT FOR 10 MINUTES (ADJUSTABLE) SUPPLY AIR LOW TEMPERATURE RESET SHALL BE ACTIVATED AND SHALL CONTINUE UNTIL BUILDING HUMIDITY FALLS BELOW SETPOINT.
- IF DURING DEHUMIDIFICATION OPERATION SUBSEQUENT HEATING IS REQUIRED TO MAINTAIN SPACE TEMPERATURE SETPOINT, THE ELECTRIC HEATING COILS IN THE VAV BOXES SHALL BE ENERGIZED AS REQUIRED TO MAINTAIN SPACE TEMPERATURE SETPOINT.
- THE TERMINAL UNITS (VAV-1 THRU VAV-9) ASSOCIATED WITH AHU-1 SHALL BE CONTROLLED BY SMARTSTRUXURE APPLICATION SPECIFIC CONTROLLERS (MR-VAV-AX). THE CONTROLLER SHALL MONITOR THE SPACE CONDITIONS BY A WALL MOUNTED THERMOSTAT AND SHALL MODULATE AIR FLOW FROM MINIMUM TO MAXIMUM CFM BASED ON THE ON BOARD FLOW TRANSDUCER AND THE VAV BOX MANUFACTURER PROVIDED FLOW RING. THE CONTROLLER SHALL INCREASE THE AIR FLOW TO PROVIDE COOLING WHEN THE SPACE TEMPERATURE RISES ABOVE COOLING SET POINT. AS SPACE TEMPERATURE APPROACHES THE SETPOINT THE CONTROLLER SHALL THROTTLE BACK THE VAV BOX TO THE MINIMUM LEVEL SCHEDULED (ADJUSTABLE). WHEN THE SPACE TEMPERATURE FALLS BELOW THE HEATING SET POINT (ADJUSTABLE) THE ELECTRIC HEAT STRIPS SHALL BE ENERGIZED UNTIL SPACE TEMPERATURE RISES ABOVE HEATING SETPOINT. THE CONTROLLER SHALL ENFORCE A DEAD BAND BEFORE ENABLING THE HEAT.

**SEQUENCE OF OPERATION: FCU-1/2 AND HP-1/2**

- SPLIT SYSTEM HEAT PUMPS FCU-1/HP-1 AND FCU-2/HP-2 SERVING THE EQUIPMENT AND TELCO ROOM SHALL MAINTAIN INTERIOR CONDITIONS AND SHALL EACH BE CONTROLLED BY A PROCESS CONTROL UNIT. THE SUPPLY FAN SHALL RUN CONTINUOUSLY IN THE OCCUPIED MODE. SUPPLEMENTAL ELECTRIC HEAT SHALL AUTOMATICALLY ENERGIZE/DE-ENERGIZE TO MAINTAIN INTERIOR CONDITIONS IN HEATING MODE.
- THE UNITS SHALL BE CONTROLLED BASED ON SPACE CONDITIONS SENSED BY THE THERMOSTATS IN BOTH THE EQUIPMENT AND TELCO ROOM. SYSTEM AND/OR SUPPLEMENT HEAT SHALL RUN/ENERGIZE WHEN CALLED FOR IN EITHER OR BOTH SPACES. MOTORIZED ISOLATION DAMPERS SHALL BE INTERLOCKED TO THEIR RESPECTIVE SUPPLY FAN MOTOR.
- ONLY ONE FCU/HP SYSTEM (PRIMARY) SHALL OPERATE AT A TIME. THE DDC SYSTEM SHALL ASSIGN ONE SYSTEM "PRIMARY" RESPONSIBILITY AND THE OTHER SYSTEM "STANDBY" RESPONSIBILITY AND SHALL REVERSE THE ASSIGNMENT BI-MONTHLY TO EQUALIZE RUN-TIME ACCUMULATION. REASSIGNMENT OF PRIMARY AND STANDBY STATUS SHALL NOT OCCUR IF A SYSTEM FAILURE FLAG IS SET. THE PRIMARY SYSTEM SHALL OPERATE TO MAINTAIN SPACE CONDITIONS. IF THE SPACE TEMPERATURE SETPOINT IS NOT REACHED AFTER TEN MINUTES (ADJUSTABLE) OF CONTINUOUS OPERATION OF THE PRIMARY SYSTEM, THE DDC SYSTEM SHALL STOP THE PRIMARY SYSTEM AND REVERSE THE PRIMARY AND STANDBY ASSIGNMENTS. THE NEWLY DESIGNATED PRIMARY SYSTEM SHALL BE STARTED. THE DDC SYSTEM SHALL SEND AN ALARM AND SHALL SET A FAILURE FLAG FOR THE STOPPED SYSTEM.
- ISOLATION DAMPERS IN THE SUPPLY AND RETURN SHALL BE INTERLOCKED WITH THEIR RESPECTIVE SUPPLY FAN AND SHALL OPEN BEFORE THE SUPPLY FAN IS STARTED AND CLOSE WHEN THE FAN IS STOPPED. THE FAN MOTOR OPERATION SHALL BE CONTROLLED BY DAMPER END POSITION SWITCHES.
- EXISTING EXHAUST FAN (ROOF MOUNTED TYPE) SERVING THE TOILETS AND JANITOR SHALL BE CONTROLLED AND RUN STATUS MONITORED VIA THE DDC SYSTEM. FAN SHALL BE CONTROLLED TO RUN DURING OCCUPIED TIMES AS DETERMINED BY OPERATION OF AHU-1.
- THE CONTROL SYSTEM SETPOINTS AND DEADBANDS SHALL BE ADJUSTABLE, AND SHALL BE SET AS FOLLOWS:

ROOM	SETPOINT COOLING/HEATING	DEADBAND COOLING/HEATING
RADAR EQUIPMENT ROOM	73°F/73°F	-2°F/+2°F
NAV/COM EQUIPMENT ROOM	73°F/73°F	-2°F/+2°F
OFFICES AND REMAINING SPACES (EXCEPT TRACON)	75°F/75°F	-2°F/+2°F







INPUT - OUTPUT SUMMARY														
POINT DESCRIPTION	INPUTS							OUTPUTS						
	ANALOG				DIGITAL			ANALOG			DIGITAL			
	HUMIDITY	TEMPERATURE	DUCT STATIC PRESSURE	DIFFERENTIAL PRESSURE	CFM	AUXILIARY CONTACT	DIFFERENTIAL PRESSURE SW	CURRENT SWITCH	0-10 VOLT CONTROL	POSITION ADJUSTMENT	CONTROL RELAY(S)			
AHU-1/CU-1														
SUPPLY AIR		X	X											
RETURN AIR	X	X												
MIXED AIR		X												
FILTER				X										
SUPPLY FAN						X		X				X		
CONDENSING UNIT STAGES							X					X		
OUTSIDE AIR		X			X				X					
MIXING BOX DAMPERS														
SPACE CO2 (2 REQ'D)				X										
SMOKE DETECTORS (2 REQ'D)						X								
EXISTING EXHAUST FAN						X						X		

INPUT - OUTPUT SUMMARY														
POINT DESCRIPTION	INPUTS							OUTPUTS						
	ANALOG				DIGITAL			ANALOG			DIGITAL			
	TEMPERATURE	DUCT STATIC PRESSURE	CO-2	DIFFERENTIAL PRESSURE	CFM	AUXILIARY CONTACT	DIFFERENTIAL PRESSURE SW	CURRENT RELAY	END POSITION SWITCH	0-10 VOLT CONTROL	POSITION ADJUSTMENT	CONTROL RELAY(S)		
FCU-1/2 HP-1/2														
SPACE	X													
SUPPLY AIR	X													
RETURN AIR	X													
MIXED AIR	X													
FILTER				X										
SUPPLY FAN						X						X		
CONDENSING UNIT STAGES												X		
REVERSING VALVE												X		
SUPPLEMENTAL HEAT STAGES												X		
MOTORIZED ISOLATION DAMPER						X		X	X					

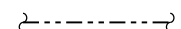
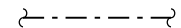
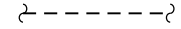
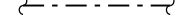
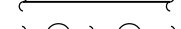
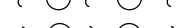
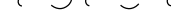
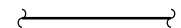
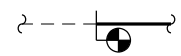
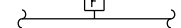
INPUT - OUTPUT SUMMARY														
POINT DESCRIPTION	INPUTS							OUTPUTS						
	ANALOG				DIGITAL			ANALOG			DIGITAL			
	TEMPERATURE	DUCT STATIC PRESSURE	CO-2	DIFFERENTIAL PRESSURE	CFM	AUXILIARY CONTACT	DIFFERENTIAL PRESSURE SW	CURRENT SWITCH	0-10 VOLT CONTROL	POSITION ADJUSTMENT	CONTROL RELAY(S)	STATUS		
VAV BOXES (VAV-1 THRU VAV-9)														
SPACE	X													
SUPPLY AIR						X								
AIR VALVE									X					
STAGES SUPPLEMENTAL HEAT												X		
AFTER HOURS OCCUPANCY							X							
AUXILIARY HEAT						X						X		

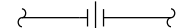
SCALES SHOWN FOR 22" X 34" SHEET. ADJUST SCALES FOR OTHER SIZES.										PAGE		OF						
										REV	APPROVED DATE	DESCRIPTION				JCN	REDLINE DATE	APVD
										DEPARTMENT OF TRANSPORTATION FEDERAL AVIATION ADMINISTRATION  FORT LAUDERDALE AIRPORT TRAFFIC CONTROL TOWER MAJOR IMPROVEMENTS MECHANICAL SEQUENCE OF OPERATION AND SYSTEM POINT LIST FT LAUDERDALE (INTERNATIONAL) FL								
WILEY WILSON 5901 Peachtree Dunwoody Rd. Bldg. C, Ste 515 Atlanta, Georgia 30328-6055 678.320.1888 wileywilson.com  WW JOB NUMBER: 219075.00										SUBMITTER'S TITLE - CIVIL ENGINEER		APPROVER'S TITLE - MANAGER						
DESIGNED		JJS	ISSUED BY		DATE JAN 31, 2020				JCN	1508912								
DRAWN		CRK	ATLANTA TERMINAL ENGINEERING CENTER		DRAWING NO				FLL-D-TRACO-M802									
CHECKED		JJS							REV									



# LEGEND

-  DOMESTIC HOT WATER PIPING
-  DOMESTIC COLD WATER PIPING
-  SANITARY VENT PIPING
-  SANITARY SEWER PIPING
-  STORM SEWER PIPING
-  RISE IN PIPING
-  DROP IN PIPING
  
-  NEW WORK AS SHOWN  
HEAVY LINE
-  CONNECTING POINT BETWEEN NEW  
PIPING AND EXISTING PIPING
-  FLOW SWITCH
-  PRESSURE GAUGE
-  UNION
  
-  EXISTING PIPING AS SHOWN  
LIGHT DASHED
-  EXISTING PIPING TO BE REMOVED
-  INTERFACING POINT BETWEEN  
EXISTING PIPING TO REMAIN AND  
EXISTING PIPING TO BE REMOVED

# PLUMBING GENERAL NOTES

1. THESE DRAWINGS ARE SCHEMATIC IN NATURE AND ARE NOT INTENDED TO SHOW ALL POSSIBLE CONDITIONS (DO NOT SCALE FOR LOCATIONS). IT IS INTENDED THAT A COMPLETE PLUMBING SYSTEM BE PROVIDED WITH ALL NECESSARY EQUIPMENT, APPURTENANCES, AND CONTROLS. THE CONTRACTOR SHALL CAREFULLY REVIEW ALL THE CONTRACT DOCUMENTS AND COORDINATE BETWEEN ALL TRADES PRIOR TO SUBMITTING SHOP DRAWINGS. THE CONTRACTOR SHALL VERIFY ALL SIZES, MATERIALS, AND TEMPERATURE AND PRESSURE RATINGS BEFORE ORDERING OR INSTALLING ANY MATERIALS OR EQUIPMENT.
2. THIS PROJECT IS A RENOVATION OF AN EXISTING FACILITY, AND PREVIOUS RECORD DRAWINGS FORM THE BASIS FOR MANY OF THESE DRAWINGS. THE CONTRACTOR SHALL FIELD VERIFY ALL DIMENSIONS PRIOR TO FABRICATION OR PURCHASE OF MATERIALS AND ASSEMBLIES. THERE MAY EXIST FIELD CONDITIONS WHICH DIFFER FROM THOSE SHOWN ON THESE DRAWINGS. ANY SUCH DEVIATIONS SHALL BE BROUGHT TO THE ATTENTION OF THE FAA CONTRACTING OFFICER REPRESENTATIVE FOR RESOLUTION BEFORE PROCEEDING WITH ANY CONSTRUCTION, FABRICATION, OR MATERIAL/EQUIPMENT PURCHASE WHICH WOULD BE UNUSABLE UNDER THOSE CIRCUMSTANCES.
3. EQUIPMENT SIZES SHOWN ARE BASED UPON TYPICAL MANUFACTURER EQUIPMENT AVAILABLE. SHOP DRAWINGS SHALL BE PROVIDED FOR REVIEW AND APPROVAL SHOWING SPACE FOR ACCESS, EGRESS, MAINTENANCE, AND REQUIRED CODE CLEARANCES PRIOR TO ANY PROCUREMENT, FABRICATION, OR INSTALLATION.
4. COORDINATE THE VOLTAGE AND PHASE OF EACH PIECE OF EQUIPMENT WITH ELECTRICAL CONTRACT DOCUMENTS PRIOR TO ORDERING. PROVIDE WRITTEN VERIFICATION OF COORDINATION WITH ELECTRICAL CONTRACT DOCUMENTS PRIOR TO INSTALLATION OF EQUIPMENT.
5. COORDINATE PIPING WITH DUCTWORK, ELECTRICAL, STRUCTURAL, AND FIRE PROTECTION. MAKE OFFSETS AND TRANSITIONS TO COORDINATE WITH OTHER TRADES WITHOUT ADDITIONAL EXPENSE TO THE GOVERNMENT. DO NOT CUT STRUCTURE.
6. FOR DRAINAGE PIPING SMALLER THAN 3", SLOPE DRAINAGE PIPING AT MINIMUM 1/4" PER FOOT IN DIRECTION OF FLOW. FOR DRAINAGE PIPING AT LEAST 3" IN SIZE AND LESS THAN OR EQUAL TO 6" IN SIZE, SLOPE PIPING AT 1/8" PER FOOT IN DIRECTION OF FLOW.
7. ALL HARDWARE, INCLUDING CLAMPS, BOLTS, NUTS, WASHERS, STRUTS, ANCHOR BOLTS, ANGLES, ETC., USED TO SUPPORT OR INSTALL ANY EXTERIOR EQUIPMENT, PIPE, CONDUIT, OR OTHER DEVICE SHALL BE STAINLESS STEEL AISI 304 OR AISI 316.
8. PROVIDE APPROPRIATE BACKFLOW PREVENTING DEVICE IN LOCATIONS WHERE POSSIBILITY OF BACK-SIPHONAGE EXISTS.
9. DO NOT ROUTE PIPING ABOVE ELECTRICAL, COMMUNICATIONS, DATA EQUIPMENT, OR ELECTRICAL PANELS.
10. PROVIDE INSULATION FOR ALL DOMESTIC PIPING AND STORM DRAIN PIPING IN CEILINGS PER SPECIFICATIONS.
11. TEST DRINKING WATER PRIOR TO PERFORMING ANY WORK.

What kind of testing required?

SCALES SHOWN FOR 22" X 34" SHEET. ADJUST SCALES FOR OTHER SIZES.		PAGE	OF
		DEPARTMENT OF TRANSPORTATION <b>FEDERAL AVIATION ADMINISTRATION</b>	
 <b>WileyWilson</b> 5901 Peachtree Dunwoody Rd. Bldg. C, Ste 515 Atlanta, Georgia 30328-6055 678.320.1888 wileywilson.com WW JOB NUMBER: 219075.00		<b>FORT LAUDERDALE AIRPORT TRAFFIC CONTROL TOWER                  MAJOR IMPROVEMENTS                  PLUMBING                  SYMBOLS AND GENERAL NOTES</b>	
FT LAUDERDALE		FL	
REV	APPROVED DATE	DESCRIPTION	JCN
REVIEWED BY		SUBMITTED BY	APPROVED BY
DESIGNED		SUBMITTER'S TITLE - CIVIL ENGINEER	APPROVER'S TITLE - MANAGER
DRAWN		ISSUED BY	DATE JAN 31, 2020
CHECKED		ATLANTA TERMINAL ENGINEERING CENTER	JCN 1508912
		DRAWING NO	REV
		FLL-D-TRACO-PO00	

Will temporary restrooms be required?

What hours are required in this area?

NOTES

- ① REPLACE EXISTING 4" SANITARY SEWER FOR ENTIRE LENGTH OF RUN TO 8" LINE WITH 4" DUCTILE IRON PIPE. APPROXIMATE LOCATION OF EXISTING 8" PIPE IS SHOWN FROM PLANS DATED 08/04/1987. SEE ATCT-P404 FOR CONTINUATION. THIS LINE SERVES RESTROOM IN THE ATCT. LINE MUST REMAIN IN OPERATION WHEN ATCT IS MANNED. COORDINATE CUTOFF TIMES WITH FAA COR.
- ② THIS IS THE MAIN ENTRANCE TO BUILDING. EGRESS NEEDS TO BE MAINTAINED DURING FAA OPERATION HOURS. COORDINATE WITH COTR ABOUT WHEN WORK CAN BE CONDUCTED.
- ③ THESE MEANS OF EGRESS NEED TO BE MAINTAINED DURING FAA OPERATION HOURS. COORDINATE WITH COTR ABOUT WHEN WORK CAN BE CONDUCTED.

GENERAL NOTES

- A. SEE TRACO-P000 FOR GENERAL NOTES AND SYMBOLS. SEE TOWB-G010 AND TOWB-G011 FOR ABBREVIATIONS.

SOD REPAIR NOTES

- 1. PRIOR TO SOIL PREPARATION, AREAS TO BE SODDED SHALL BE BROUGHT TO FINAL GRADE IN ACCORDANCE WITH THE APPROVAL PLAN. THESE OPERATIONS SHOULD LEAVE AS MUCH TOPSOIL AS POSSIBLE OR REPLACE THE TOPSOIL TO A DEPTH OF FOUR INCHES.
- 2. PRIOR TO LAYING SOD, THE SOIL SURFACE SHALL BE CLEAR OF TRASH, DEBRIS, ROOTS, BRANCHES, STONES AND CLODS IN EXCESS OF 2 INCHES IN LENGTH OR DIAMETER. SOD SHALL NOT BE APPLIED TO GRAVEL OR OTHER NON-SOIL SURFACES.
- 3. SOD SHOULD BE FREE OF WEEDS AND UNDESIRABLE COARSE WEEDY GRASSES. IF POSSIBLE, CERTIFIED OR APPROVED TURFGRASS SOD SHOULD BE USED.
- 4. SOD SHALL BE NOT CUT OR LAID IN EXCESSIVELY WET OR DRY WEATHER.
- 5. SOD SHALL BE HARVESTED, DELIVERED, AND INSTALLED WITHIN A PERIOD OF 36 HOURS.
- 6. IRRIGATE AREAS TO BE SODDED WITH A MINIMUM OF 1-INCH OF WATER UNLESS RECENT RAINS HAVE PROVIDED EQUIVALENT MOISTURE.
- 7. AS SODDING OF CLEARLY DEFINED AREAS IS COMPLETED, SOD SHALL BE ROLLED OR TAMPED TO PROVIDE FIRM CONTACT BETWEEN ROOTS AND SOIL.
- 8. AFTER ROLLING, SOD SHALL BE IRRIGATED TO A DEPTH SUFFICIENT THAT THE UNDERSIDE OF THE SOD PAD AND THE SOIL 4 INCHES BELOW THE SOD IS THOROUGHLY WET.
- 9. DURING THE FIRST WEEK, IN THE ABSENCE OF ADEQUATE RAINFALL, WATERING SHALL BE PERFORMED AS OFTEN AS NECESSARY TO MAINTAIN MOIST SOIL TO A DEPTH OF AT LEAST 4 INCHES.

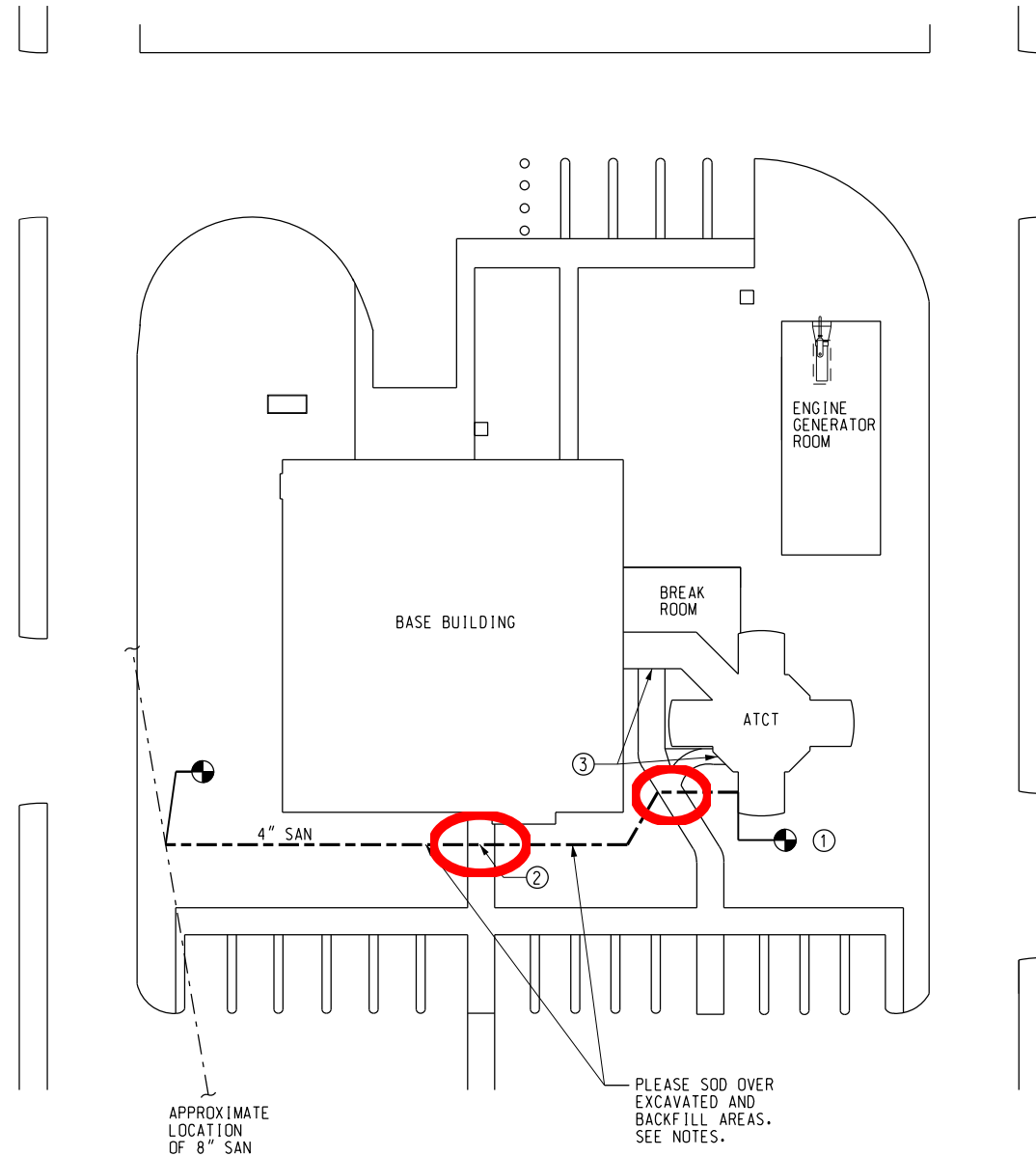

APPROXIMATE LOCATION OF 8" SAN

PLEASE SOD OVER EXCAVATED AND BACKFILL AREAS. SEE NOTES.

1 PLUMBING SITE PLAN  
P050 SCALE: 1" = 20'-0"

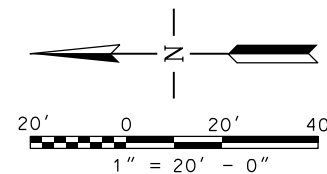

SCALES SHOWN FOR 22" X 34" SHEET. ADJUST SCALES FOR OTHER SIZES. PAGE OF

REV	APPROVED DATE	DESCRIPTION	JCN	REDLINE DATE	APVD
DEPARTMENT OF TRANSPORTATION <b>FEDERAL AVIATION ADMINISTRATION</b>  <b>FORT LAUDERDALE AIRPORT TRAFFIC CONTROL TOWER</b> <b>MAJOR IMPROVEMENTS</b> <b>PLUMBING</b> <b>SITE PLAN</b> FT LAUDERDALE (INTERNATIONAL) FL					
REVIEWED BY		SUBMITTED BY		APPROVED BY	
DESIGNED		ISSUED BY		DATE	
DRAWN		ATLANTA TERMINAL ENGINEERING CENTER		JAN 31, 2020	
CHECKED				JCN 1508912	
				DRAWING NO. FLL-D-TRACO-P050	

**WileyWilson**  
5901 Peachtree Dunwoody Rd.  
Bldg. C, Ste 515  
Atlanta, Georgia 30328-6055  
678.320.1888  
wileywilson.com  
WW JOB NUMBER: 219075.00

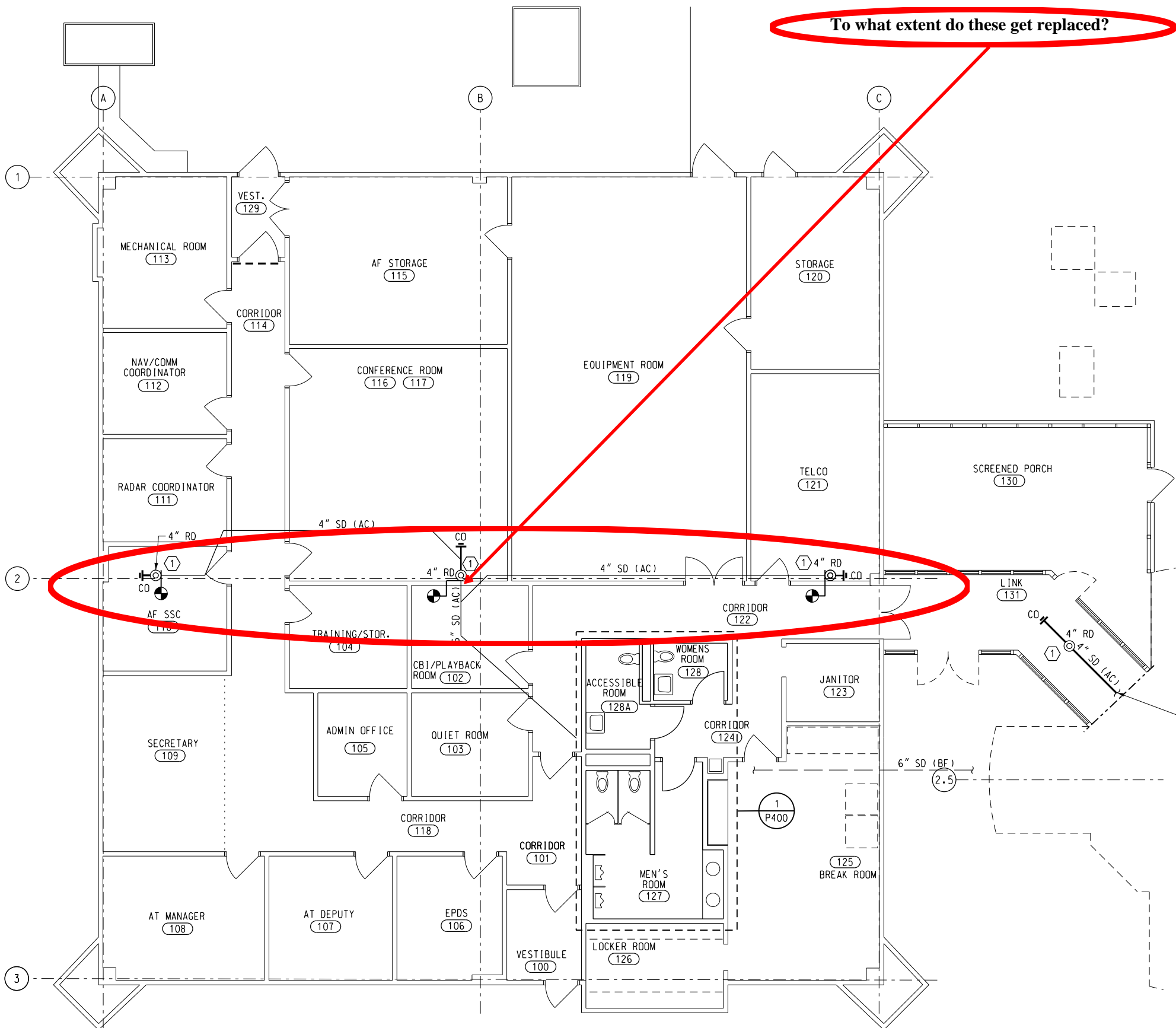

**NOTES**

1. INSTALL NEW 4" ROOF DRAIN AND CONDUCTOR. REPLACE EXISTING TEE FITTING AND CLEANOUT TO ACCOMMODATE A 4" PIPE. SEE DETAIL 4, TRACO-A610 FOR MORE INFORMATION. THIS WORK WILL REQUIRE REMOVAL AND REPLACEMENT OF CEILING TILES. COORDINATE WITH COTR BEFORE COMMENCING WORK.

**GENERAL NOTES**

- SEE DRAWING TRACO-P000 FOR PLUMBING LEGEND, GENERAL NOTES, AND SPECIAL NOTES.
- CONTRACTOR SHALL NOTIFY ENGINEER IN WRITING IF SITE CONDITIONS DEVIATE SIGNIFICANTLY FROM CONTRACT DOCUMENTS.

**LEGEND**

- NEW PIPES WORK
- EXISTING PIPES TO REMAIN

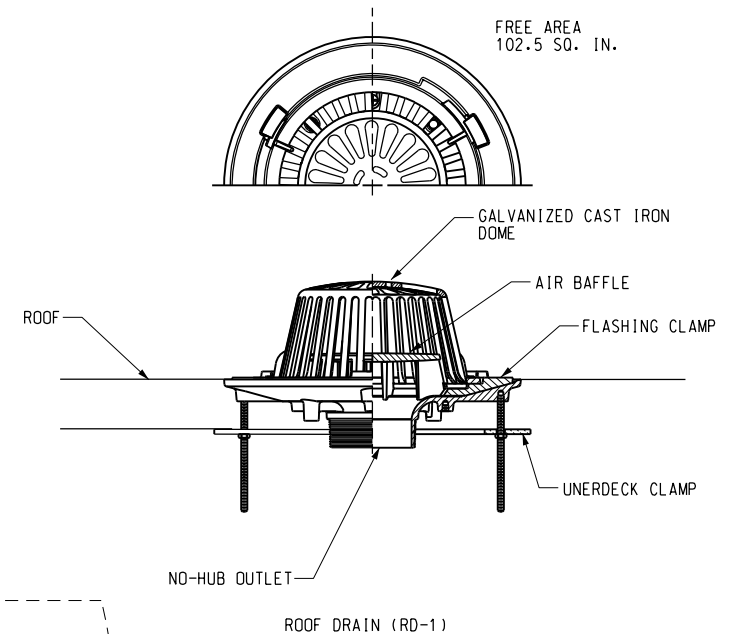

**2 TYPICAL ROOF DRAINS**  
P100 NOT TO SCALE

**1 BASE BUILDING FLOOR PLAN - NEW WORK**  
P100 SCALE: 3/16" = 1' - 0"

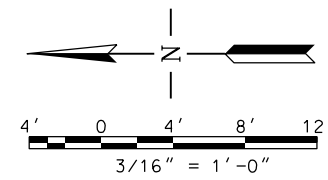

SCALES SHOWN FOR 22" X 34" SHEET. ADJUST SCALES FOR OTHER SIZES. PAGE **OF**

**WileyWilson**  
5901 Peachtree Dunwoody Rd.  
Bldg. C, Ste 515  
Atlanta, Georgia 30328-6055  
678.320.1888  
wileywilson.com  
WW JOB NUMBER: 219075.00

REV	APPROVED DATE	DESCRIPTION	JCN	REDLINE DATE	APVD

DEPARTMENT OF TRANSPORTATION  
**FEDERAL AVIATION ADMINISTRATION**

**FORT LAUDERDALE AIRPORT TRAFFIC CONTROL TOWER  
MAJOR IMPROVEMENTS**

**PLUMBING**

**BASE BUILDING FLOOR PLAN - NEW WORK**

FT LAUDERDALE (INTERNATIONAL) FL

DESIGNED BY: JJS	ISSUED BY: JCN	DATE: JAN 31, 2020	JCN 1508912
DRAWN BY: CRK	ATLANTA TERMINAL ENGINEERING CENTER	DRAWING NO:	FLL-D-TRACO-P100
CHECKED BY: JJS			



**POWER**

SYMBOL	MOUNTING HEIGHT, AFF	DESCRIPTION
	+18"	SINGLE HEAVY DUTY RECEPTACLE, 20A, 125V, WALL MOUNTED
	+18"	QUADRUPLIX HEAVY DUTY RECEPTACLE, 20A, 125V, WALL MOUNTED
	+18"	DUPLEX HEAVY DUTY RECEPTACLE, 20A, 125V, WALL MOUNTED 'WP' DESIGNATES WEATHER PROOFING.
	+18"	DUPLEX HEAVY DUTY RECEPTACLE, GFI, 20A, 125V, WALL MOUNTED 'WP' DESIGNATES WEATHER PROOFING. PROVIDE WITH IN-USE WEATHER PROTECTIVE COVERS.
		DUPLEX HEAVY DUTY RECEPTACLE, 20A, 125V, FLOOR MOUNTED
	+18"	SPECIAL PURPOSE OUTLET NEMA RATING INDICATED
S	+48"	SPST, HEAVY DUTY TOGGLE SWITCH, UON

SUBSCRIPT INDICATES  
 3 = 3-WAY  
 4 = 4-WAY  
 D = DIMMER SWITCH  
 k = KEY OPERATED  
 m = MANUAL MOTOR STARTER WITH THERMAL OVERLOADS  
 2P = TWO-POLE MANUAL MOTOR STARTER  
 OS = OCCUPANCY SENSOR: LEVITON OSSMT-MD OR APPROVED EQUAL  
 GFI = PROVIDE WITH GROUND FAULT PROTECTION

OCCUPANCY SENSOR, DUAL TECHNOLOGY

**PULL BOXES / JUNCTION BOXES**

SYMBOL	DESCRIPTION
	JUNCTION BOX.

**MOTORS**

SYMBOL	MOUNTING HEIGHT, AFF UON	DESCRIPTION
	+60"	MAGNETIC MOTOR STARTER, NEMA SIZE AS INDICATED
	+60"	COMBINATION MOTOR STARTER, NEMA SIZE AS INDICATED
	+60"	UNFUSED DISCONNECT SWITCH, WHERE 60/3 INDICATES NEMA FRAME SIZE/NUMBER OF POLES
	+60"	FUSED DISCONNECT SWITCH, WHERE 60/40/3 INDICATES NEMA FRAME SIZE/FUSE SIZE/NUMBER OF POLES
		MOTOR

**MISCELLANEOUS**

SYMBOL	DESCRIPTION
	TRANSFORMER

**PANELBOARDS AND CABINETS**

SYMBOL	MOUNTING HEIGHT, AFF	DESCRIPTION
	+78" (TOP)	3 PHASE, 4 WIRE PANELBOARD, SURFACE MOUNTED, 208/120V, ESSENTIAL OR CRITICAL

**SINGLE-LINE DIAGRAM**

SYMBOL	DESCRIPTION
	TRANSFORMER
	MOLDED CASE CIRCUIT BREAKER
	GROUND

**RACEWAYS**

SYMBOL	DESCRIPTION
	CONDUIT, CONCEALED IN WALLS, CEILING OR EXPOSED
	UNDERGROUND/SLAB CONDUIT
	CONDUIT TURNING UP
	CONDUIT TURNING DOWN
	CONDUIT CAPPED
	FLEXIBLE CONDUIT
	LT = LIQUID TIGHT CABLE TRAY
	ESSENTIAL WIREWAY (4" SQUARE DUCT)
	CRITICAL WIREWAY (4" SQUARE DUCT)
	DUCTBANK
	COMMUNICATION MANHOLE
	ELECTRICAL (POWER) MANHOLE
	CABLE MARKER

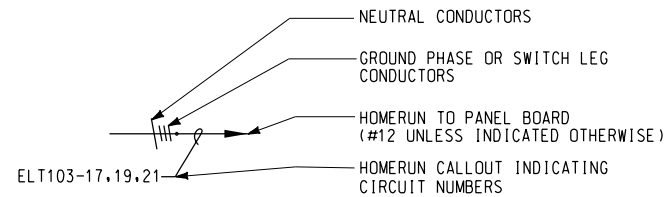

NO TALLIES INDICATE 2 #12 & 1 #12G - 3/4" C. UON EACH CIRCUIT SHALL HAVE SEPARATE, DEDICATED NEUTRAL AND GROUND CONDUCTORS.

**GROUNDING AND LIGHTNING PROTECTION**

SYMBOL	DESCRIPTION
	GROUND ROD, 10'-0"x3/4" DIA COPPER CLAD STEEL
	GROUND ACCESS WELL
	RAISED FLOOR PEDESTAL GROUND
	AIR TERMINAL (LIGHTNING PROTECTION)
	GROUND PLATE SUBSCRIPT INDICATES: M = MULTIPOINT GROUND B = ANTENNA LIGHTNING BULKHEAD PLATE
	BARE COPPER GROUNDING CONDUCTOR UNDERGRADE/IN SLAB
	COPPER GROUNDING CONDUCTOR, EXPOSED
	BONDING/SPLICING CONNECTION

LUMINAIRE SCHEDULE									
TYPE	FIXTURE DESCRIPTION	OR APPROVED EQUAL		FIXTURE DATA			LAMP DATA		REMARKS
		MANUFACTURER	CATALOG NUMBER	MOUNTING	VOLTAGE	INPUT WATTAGE	QTY	TYPE	
A	LED DOWNLIGHT, 6" ROUND APERTURE	GREEN CREATIVE	SELECTFIT SERIES: SLFT6-80CCTS-DIM120V-LOW	CEILING	120	8	-	LED DRIVER	CONNECT TO EXISTING CIRCUIT. PROVIDE INTEGRAL EMERGENCY INVERTER FOR FIXTURES INDICATED WITH "E"
B	LED VANITY WALL SCNCE	KUZCO LIGHTING	CHARLOTTE SERIES: 601464CH-LED	WALL	120	29.5	-	LED DRIVER	CONNECT TO EXISTING CIRCUIT. MOUNT AT 7'-0" AFF TO TOP OF WALL SCNCE
SA	LED AREA LUMINAIRE	LITHONIA LIGHTING	D-SERIES: DSX1 LED-P1-40K-T4M-MVOLT-SPA	POLE	120	64	-	LED DRIVER	PROVIDE NEW CIRCUIT, CONNECT TO EXISTING CONTROLS. MOUNT TO NEW 25' TALL SQUARE POLE
SB	LED AREA LUMINAIRE	LITHONIA LIGHTING	D-SERIES: DSX1 LED-P1-40K-T5W-MVOLT-SPA	POLE	120	108	-	LED DRIVER	PROVIDE NEW CIRCUIT, CONNECT TO EXISTING CONTROLS. MOUNT TO NEW 25' TALL SQUARE POLE, 2 FIXTURES @ 90deg.
SF	LED FLOOD LIGHT FIXTURE	OPTEC LIGHTING	FLOODLIGHT SERIES: OLFLM-670-UNVL-40-7X8-TA-BL-WG	TENON	120	70	-	LED DRIVER	CONNECT TO EXISTING CIRCUIT. REPLACE FIXTURES MOUNTED TO EXISTING TENON
SW	LED WALL PACK	LITHONIA LIGHTING	D-SERIES: DSXW1 LED-10C-530-40K-T4M-MVOLT	WALL	120	19	-	LED DRIVER	CONNECT TO EXISTING CIRCUIT & CONTROLS. SURFACE MOUNT TO LOCATION INDICATED IN DRAWINGS
XA	WHITE LED EXIT SIGN	LITHONIA LIGHTING	LIGHT STYLE SERIES: LQM-S-WR-120/277-ELN-SD	WALL / CEILING	120	-	-	LED DRIVER	CONNECT TO EXISTING CIRCUIT. SURFACE MOUNT TO LOCATION INDICATED IN DRAWINGS
XB	LED EMERGENCY LIGHT	LITHONIA LIGHTING	QUANTUM SERIES: ELM4L-UVOLT-LTP	WALL	120	6.6	-	LED DRIVER	CONNECT TO EXISTING CIRCUIT. SURFACE MOUNT TO LOCATION INDICATED IN DRAWINGS
XC	BLACK LED EXIT SIGN	LITHONIA LIGHTING	LIGHT STYLE SERIES: LQM-S-R-120/277-ELN-SD	WALL / CEILING	120	-	-	LED DRIVER	CONNECT TO EXISTING CIRCUIT. SURFACE MOUNT TO LOCATION INDICATED IN DRAWINGS

SCALES SHOWN FOR 22" X 34" SHEET. ADJUST SCALES FOR OTHER SIZES. PAGE OF

**WileyWilson**  
 5901 Peachtree Dunwoody Rd.  
 Bldg. C, Ste 515  
 Atlanta, Georgia 30328-6055  
 678.320.1888  
 wileywilson.com  
 WW JOB NUMBER: 219075.00

REV	APPROVED DATE	DESCRIPTION	JCN	REDLINE DATE	APVD

**DEPARTMENT OF TRANSPORTATION  
FEDERAL AVIATION ADMINISTRATION**

**FORT LAUDERDALE AIRPORT TRAFFIC CONTROL TOWER  
MAJOR IMPROVEMENTS  
ELECTRICAL  
LEGEND AND SYMBOLS**

FT LAUDERDALE (INTERNATIONAL) FL

REVIEWED BY	SUBMITTED BY	APPROVED BY
SUBMITTER'S TITLE - CIVIL ENGINEER		APPROVER'S TITLE - MANAGER
DESIGNED JMC	ISSUED BY	DATE JAN 31, 2020 JCN 1508912
DRAWN CRK	ATLANTA TERMINAL ENGINEERING CENTER	DRAWING NO
CHECKED MAK		FLL-D-TRACO-E000 REV





**GENERAL NOTES**

1. PROVIDE CONNECTIONS TO ALL MOTORS, TO ALL HVAC AND PLUMBING EQUIPMENT AND TO ALL OTHER EQUIPMENT PROVIDED UNDER OTHER DIVISIONS OF WORK FROM DISCONNECT SWITCH, STARTER, J-BOX, ETC. UNLESS OTHERWISE NOTED.
2. ALL CIRCUITS SHALL INCLUDE A GREEN EQUIPMENT GROUNDING CONDUCTOR.
3. ALL HARDWARE, INCLUDING CLAMPS, BOLTS, NUTS, WASHERS, STRUTS, ANCHOR BOLTS, ANGLES, ETC. USED TO SUPPORT OR INSTALL ANY EXTERIOR (AND NON-CONDITIONED LOCATIONS) HANDRAIL, EQUIPMENT, PIPE, CONDUIT, BOX OR OTHER DEVICE SHALL BE STAINLESS STEEL ANSI 316.
4. SEE MECHANICAL DRAWINGS FOR EQUIPMENT SCHEDULES AND DETAILS.
5. PROVIDE PULLBOX IN ALL CONDUIT CIRCUITS THAT EXCEED FOUR NINETY DEGREE TURNS. COORDINATE LOCATION OF PULLBOXES WITH CONDUIT, LIGHTS, DUCTWORK, PIPING, ETC.
6. FOR TOWER CONDUIT RISERS- EXPOSED/SURFACE MOUNTED CONDUIT IS ACCEPTABLE IN THE TOWER WITH THE EXCEPTION OF AREAS WITH SUSPENDED CEILINGS. CONDUIT IN AREAS OF SUSPENDED CEILINGS SHALL BE RUN ABOVE THE CEILING OR CONCEALED IN WALLS.
7. FOR TOWER CONDUIT RISERS- REQUIRED PENETRATIONS SHALL BE NEATLY CORE DRILLED WITH GALVANIZED STEEL SLEEVES INSTALLED.
8. CIRCUITS FROM EACH OVERCURRENT DEVICE SHALL HAVE A DEDICATED NEUTRAL AND GROUND CONDUCTOR; NO CIRCUITS WITH SHARED NEUTRALS SHALL BE ALLOWED.
9. ALL ELECTRICAL WORK SHALL CONFORM TO THE NATIONAL ELECTRICAL CODE 2017, NFPA 780, FAA-STD-1217H, AND FAA SPEC 1217G.
10. NEW AND REPLACEMENT CIRCUIT BREAKERS INSTALLED IN PANELBOARDS SHALL MATCH EXISTING BREAKERS OF SIMILAR FRAME SIZE, INCLUDING VOLTAGE RATING AND INTERRUPTING CAPACITY.
11. POWER CIRCUITS FOR HVAC EQUIPMENT ARE SHOWN ON ELECTRICAL DRAWINGS.
12. MINIMUM CONDUIT SIZE SHALL BE 3/4". MINIMUM POWER CONDUCTOR SIZE SHALL BE #12 THWN/THHN COPPER.

**GROUNDING AND LIGHTNING PROTECTION NOTES**

1. THE COMPLETED GROUNDING AND LIGHTNING PROTECTION SYSTEM SHALL MEET THE "INSTALLATION REQUIREMENTS FOR LIGHTNING PROTECTION SYSTEMS, UL96A-MOST CURRENT EDITION". COMPLY WITH FAA-STD-1217H AND FAA-STD-019F.
2. THE LIGHTNING PROTECTION SYSTEM COMPONENTS SHALL COMPLY WITH NFPA 780 CLASS-II SYSTEM INSTALLATION REQUIREMENTS.
3. ALL METALLIC DEVICES WITHIN 6' OF ROOF COUNTERPOISE OR DOWN CONDUCTORS SHALL BE BONDED TO LIGHTNING PROTECTION SYSTEM.

SCALES SHOWN FOR 22" X 34" SHEET. ADJUST SCALES FOR OTHER SIZES.			<b>PAGE</b>	<b>OF</b>
				
 <b>WileyWilson</b> 5901 Peachtree Dunwoody Rd. Bldg. C, Ste 515 Atlanta, Georgia 30328-6055 678.320.1888 wileywilson.com WW JOB NUMBER: 219075.00				
REV	APPROVED DATE	DESCRIPTION	JCN	REDLINE DATE
DEPARTMENT OF TRANSPORTATION <b>FEDERAL AVIATION ADMINISTRATION</b>  <b>FORT LAUDERDALE AIRPORT TRAFFIC CONTROL TOWER</b> <b>MAJOR IMPROVEMENTS</b> <b>ELECTRICAL</b> <b>GENERAL NOTES</b>  FT LAUDERDALE (INTERNATIONAL) FL				
REVIEWED BY	SUBMITTED BY	DESIGNED	DRAWN	CHECKED
		JMC	JMC	MAK
		SUBMITTER'S TITLE - CIVIL ENGINEER	APPROVER'S TITLE - MANAGER	
		ISSUED BY	DATE JAN 31, 2020	
		ATLANTA TERMINAL ENGINEERING CENTER	JCN 1508912	REV
			DRAWING NO. FLL-D-TRACO-E001	

**GENERAL NOTES**

- A. NEW WORK IS SHOWN AS HEAVY LINE ON PLANS AND EXISTING WORK SHOWN IS LIGHT SOLID LINE.
- B. SEE DRAWING TRACO-E000 AND TRACO-E001 FOR ELECTRICAL LEGEND, GENERAL NOTES AND SPECIAL NOTES.

**KEY NOTES**

- ① EXISTING SECURITY LIGHT TO BE REPLACED. CONNECT NEW FIXTURE TO EXISTING CIRCUIT AND TIMER, SERVED BY PANEL NLPA-1.
- ② REPLACE EXISTING LIGHT FIXTURE WITH NEW LED FLOOD LIGHT FIXTURE HEAD. CONNECT TO EXISTING CIRCUIT FED FROM PANEL NLPA-1 AND TIME CLOCK CONTROLS.
- ③ NEW 25FT LED LIGHT POLE FIXTURE. CONNECT FIXTURE TO EXISTING SITE LIGHTING CIRCUIT AND PHOTOCELL/TIME CLOCK USING 2#12, #12G IN 3/4" C. EXISTING CIRCUIT IS SERVED BY PANEL EPGL LOCATED IN ELECTRICAL ROOM EG02. SEE DETAIL 5, TRACO-E601 FOR POLE BASE INFORMATION.
- ④ NEW EXHAUST FAN EF-2. CONNECT TO EXISTING CIRCUIT AND CONDUIT SERVED FROM PANEL NPA. EXTEND WIRE AND CONDUIT AS REQUIRED FOR NEW CONNECTION.

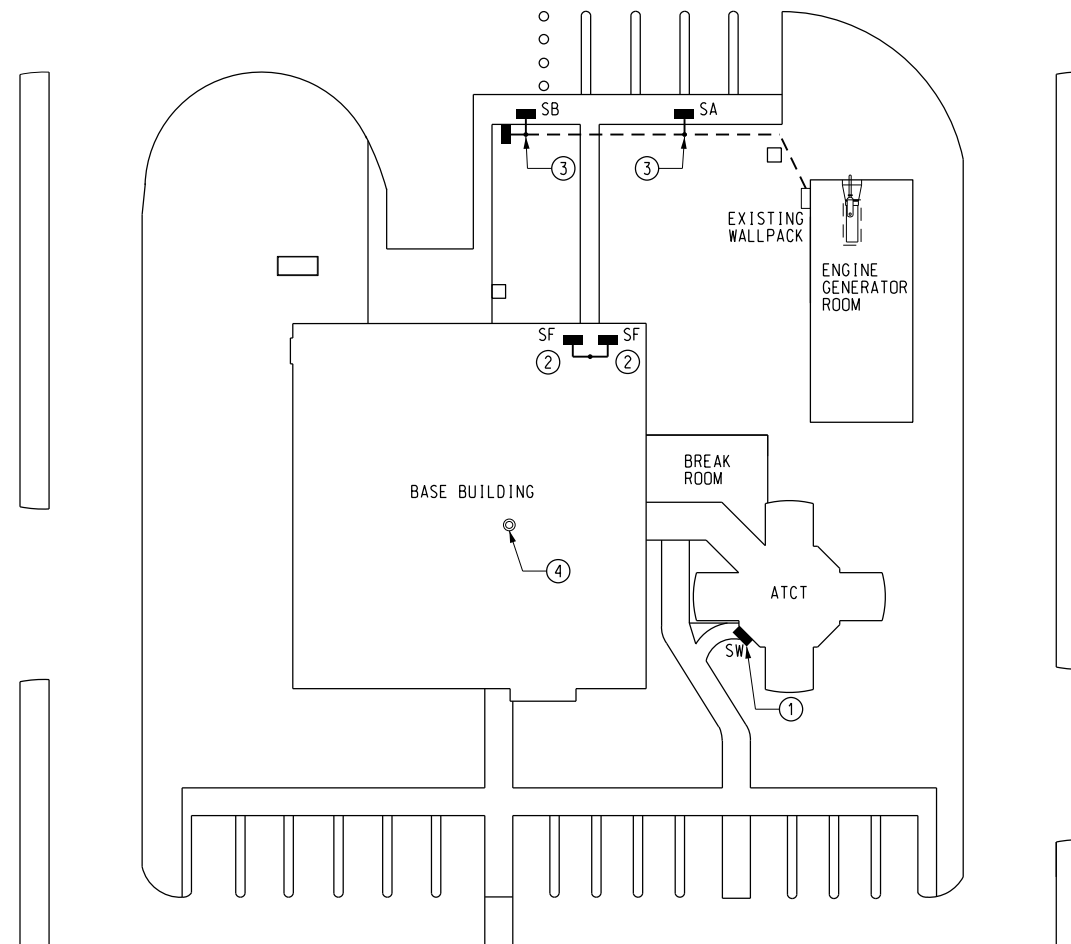

**1 ELECTRICAL SITE PLAN**  
 E050 SCALE: 1" = 20'-0"

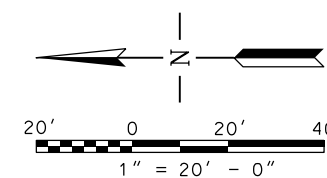

SCALES SHOWN FOR 22" X 34" SHEET. ADJUST SCALES FOR OTHER SIZES.		PAGE	OF
REV	APPROVED DATE	DESCRIPTION	JCN REDLINE DATE APVD
DEPARTMENT OF TRANSPORTATION FEDERAL AVIATION ADMINISTRATION			
FORT LAUDERDALE AIRPORT TRAFFIC CONTROL TOWER MAJOR IMPROVEMENTS ELECTRICAL SITE PLAN			
FT LAUDERDALE		(INTERNATIONAL)	FL
REVIEWED BY	SUBMITTED BY	APPROVED BY	
SUBMITTER'S TITLE - CIVIL ENGINEER		APPROVER'S TITLE - MANAGER	
DESIGNED	BRP	ISSUED BY	DATE JAN 31, 2020 JCN 1508912
DRAWN	CRK	ATLANTA TERMINAL ENGINEERING CENTER	DRAWING NO
CHECKED	MRK		FLL-D-TRACO-E050 REV
WW JOB NUMBER: 219075.00			

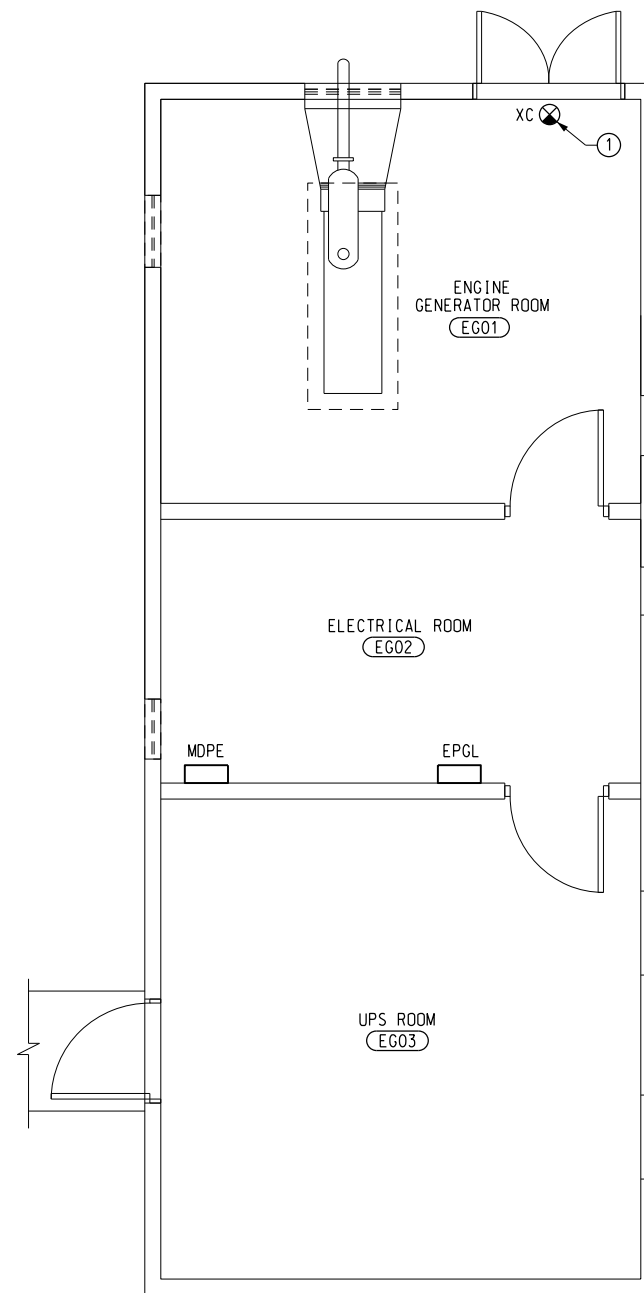

1 GENERATOR BUILDING PLAN  
 E060 SCALE: 1/4" = 1'-0"

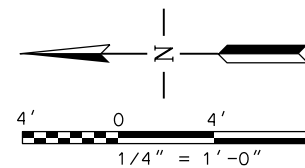

GENERAL NOTES

- A. NEW WORK IS SHOWN AS HEAVY LINE ON PLANS AND EXISTING WORK SHOWN IS LIGHT SOLID LINE.
- B. SEE DRAWING TRACO-E000 AND TRACO-E001 FOR ELECTRICAL LEGEND, GENERAL NOTES AND SPECIAL NOTES.

KEY NOTES

- ① PROVIDE NEW LED EXIT SIGN WITH 90 MINUTE BATTERY BACKUP. CONNECT NEW EXIT SIGN TO EXISTING EMERGENCY CIRCUIT FED FROM PANEL EPGL.

SCALES SHOWN FOR 22" X 34" SHEET. ADJUST SCALES FOR OTHER SIZES.				PAGE	OF
REV	APPROVED DATE	DESCRIPTION	JCN	REDLINE DATE	APVD
DEPARTMENT OF TRANSPORTATION FEDERAL AVIATION ADMINISTRATION  FORT LAUDERDALE AIRPORT TRAFFIC CONTROL TOWER MAJOR IMPROVEMENTS ELECTRICAL GENERATOR BUILDING PLAN  FT LAUDERDALE (INTERNATIONAL) FL					
REVIEWED BY		SUBMITTED BY		APPROVED BY	
DESIGNED		SUBMITTER'S TITLE - CIVIL ENGINEER		APPROVER'S TITLE - MANAGER	
DRAWN		ISSUED BY		DATE JAN 31, 2020 JCN 1508912	
CHECKED		ATLANTA TERMINAL ENGINEERING CENTER		DRAWING NO. FLL-D-TRACO-E060	
 <b>WileyWilson</b> 5901 Peachtree Dunwoody Rd. Bldg. C, Ste 515 Atlanta, Georgia 30328-6055 678.320.1888 wileywilson.com WW JOB NUMBER: 219075.00					

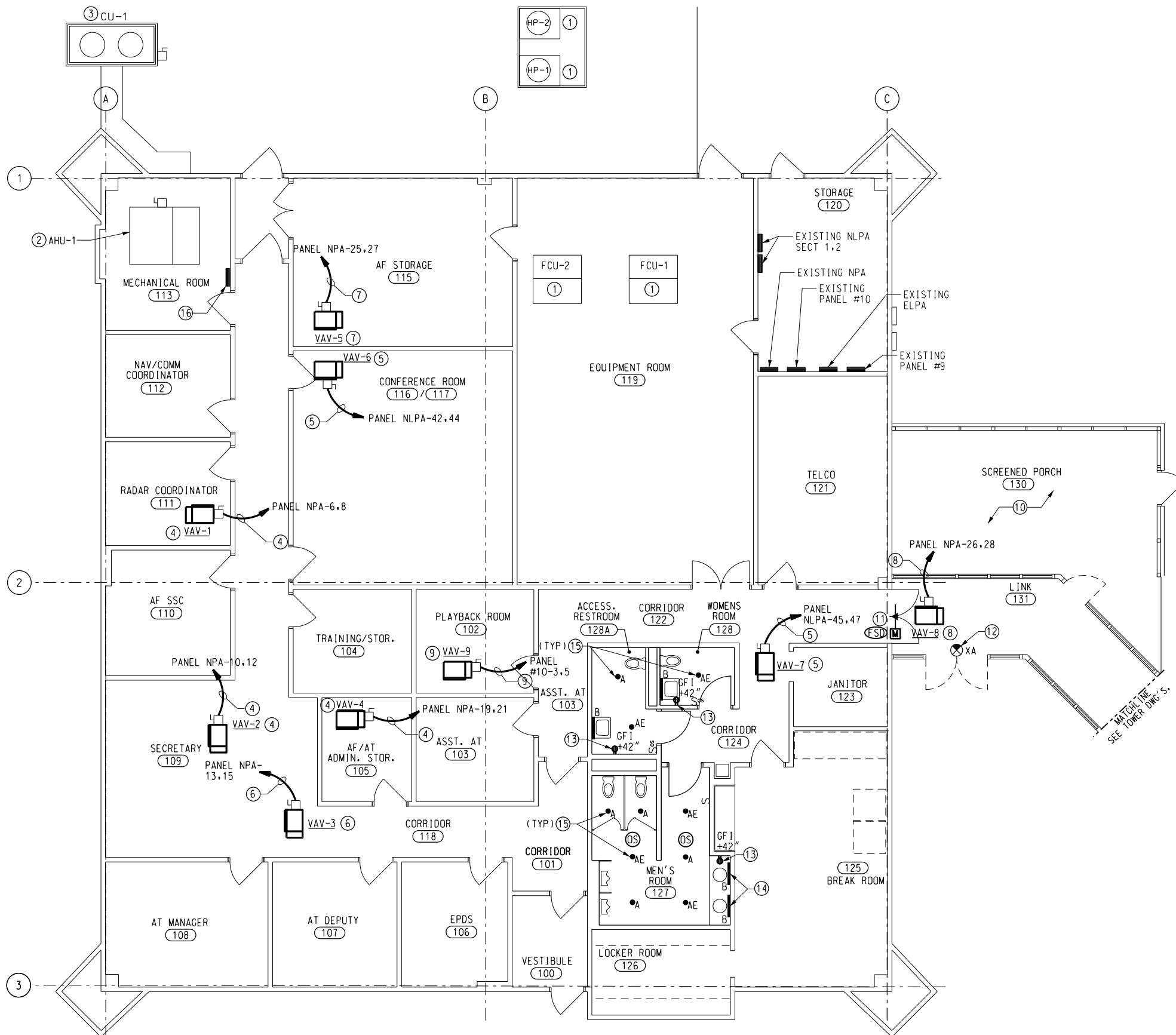

**KEY NOTES**

- ① EXISTING MECHANICAL EQUIPMENT TO REMAIN.
- ② EXISTING MECHANICAL UNIT AHU-1.
- ③ EXISTING MECHANICAL UNIT CU-1.
- ④ NEW MECHANICAL VAV UNIT. FACTORY INSTALLED INTEGRAL DISCONNECT PROVIDED BY MECHANICAL CONTRACTOR. PROVIDE 20A, 2-POLE BREAKER IN PANEL NPA. USE EXISTING BREAKER IF APPLICABLE. REPLACE CIRCUIT WIRING BACK TO PANEL WITH NEW 3-#12AWG, #12G IN EXISTING 3/4" C.
- ⑤ NEW MECHANICAL VAV UNIT. FACTORY INSTALLED INTEGRAL DISCONNECT PROVIDED BY MECHANICAL CONTRACTOR. PROVIDE 20A, 2-POLE BREAKER IN PANEL NLPA SECT 2, USE EXISTING BREAKER IF APPLICABLE. REPLACE CIRCUIT WIRING BACK TO PANEL WITH NEW 3-#12AWG, #12G IN EXISTING 3/4" C.
- ⑥ NEW MECHANICAL VAV UNIT. FACTORY INSTALLED INTEGRAL DISCONNECT PROVIDED BY MECHANICAL CONTRACTOR. USE EXISTING 40A 2-POLE BREAKER IN PANEL NPA. REPLACE CIRCUIT WIRING BACK TO PANEL WITH NEW 3-#8AWG, #10G IN EXISTING 3/4" C.
- ⑦ NEW MECHANICAL VAV UNIT. FACTORY INSTALLED INTEGRAL DISCONNECT PROVIDED BY MECHANICAL CONTRACTOR. REPLACE BREAKER IN PANEL NPA WITH 30A, 2-POLE BREAKER. REPLACE CIRCUIT WIRING BACK TO PANEL WITH NEW 3-#10AWG, #10G IN EXISTING 3/4" C.
- ⑧ NEW MECHANICAL VAV UNIT. FACTORY INSTALLED INTEGRAL DISCONNECT PROVIDED BY MECHANICAL CONTRACTOR. REPLACE BREAKER IN PANEL NPA WITH 60A, 2-POLE BREAKER. CONTRACTOR SHALL REPLACE CIRCUIT WIRING AND CONDUIT BACK TO PANEL WITH NEW 3-#6AWG, #10G IN 1" C.
- ⑨ NEW MECHANICAL VAV UNIT. FACTORY INSTALLED INTEGRAL DISCONNECT PROVIDED BY MECHANICAL CONTRACTOR. PROVIDE 20A, 2-POLE BREAKER IN PANEL #10. CONTRACTOR SHALL PROVIDE NEW 3-#12AWG, #12G IN 3/4" C.
- ⑩ REINSTALL EXISTING CEILING FANS AND LIGHT FIXTURES FOLLOWING COMPLETION OF ARCHITECTURAL REMODELLING.
- ⑪ EXISTING FIRE SMOKE DAMPERS 1 & 2 TO BE REPLACED. DISCONNECT AND RECONNECT TO EXISTING CIRCUIT BEING FED FROM PANEL #9, CIRCUIT #16. REFER TO MECHANICAL DETAILS FOR MORE INFORMATION. COORDINATE ANY NEW LOCATIONS WITH MECHANICAL.
- ⑫ PROVIDE NEW LED EXIT SIGN WITH 90-MINUTE BATTERY BACKUP. CONNECT NEW TO EXISTING EMERGENCY CIRCUIT FED BY PANEL #9.
- ⑬ PROVIDE NEW GFI RECEPTACLE AND CONNECT TO EXISTING CIRCUIT SERVING SPACE FED BY PANEL NLPA-2.
- ⑭ NEW LED VANITY FIXTURE CONNECT TO EXISTING LIGHTING CIRCUIT FED BY PANEL NLPA-2.
- ⑮ NEW LED DOWNLIGHT CONNECT TO EXISTING CIRCUIT FED BY PANEL NLPA-2.
- ⑯ NEW DDC CONTROL PANEL. PROVIDE NEW CIRCUIT FROM PANEL #9-17. CONNECT CIRCUIT TO NEW 20A CIRCUIT BREAKER USING 2#12, #12G IN 3/4" CONDUIT.

**1 BASE BUILDING POWER PLAN**  
E120 SCALE: 3/16" = 1' - 0"

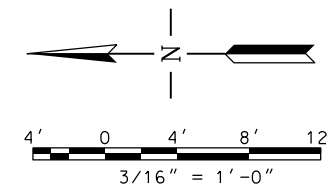

SCALES SHOWN FOR 22" X 34" SHEET. ADJUST SCALES FOR OTHER SIZES.		PAGE	OF
		REV	APPROVED DATE
<b>DEPARTMENT OF TRANSPORTATION FEDERAL AVIATION ADMINISTRATION</b>		DESCRIPTION	JCN
<b>FORT LAUDERDALE AIRPORT TRAFFIC CONTROL TOWER MAJOR IMPROVEMENTS ELECTRICAL BASE BUILDING POWER PLAN</b>		REVISION DATE	APVD
<b>WileyWilson</b> 5901 Peachtree Dunwoody Rd. Bldg. C, Ste 515 Atlanta, Georgia 30328-6055 678.320.1888 wileywilson.com WW JOB NUMBER: 219075.00		<b>FT LAUDERDALE (INTERNATIONAL) FL</b>	
DESIGNED BY	BRP	ISSUED BY	ATLANTA TERMINAL ENGINEERING CENTER
DRAWN BY	CRK	DATE	JAN 31, 2020
CHECKED BY	MAK	JCN	1508912
SUBMITTER'S TITLE - CIVIL ENGINEER		APPROVER'S TITLE - MANAGER	
REVIEWED BY		APPROVED BY	
SUBMITTED BY		DRAWING NO	
		FLL-D-TRACO-E120	

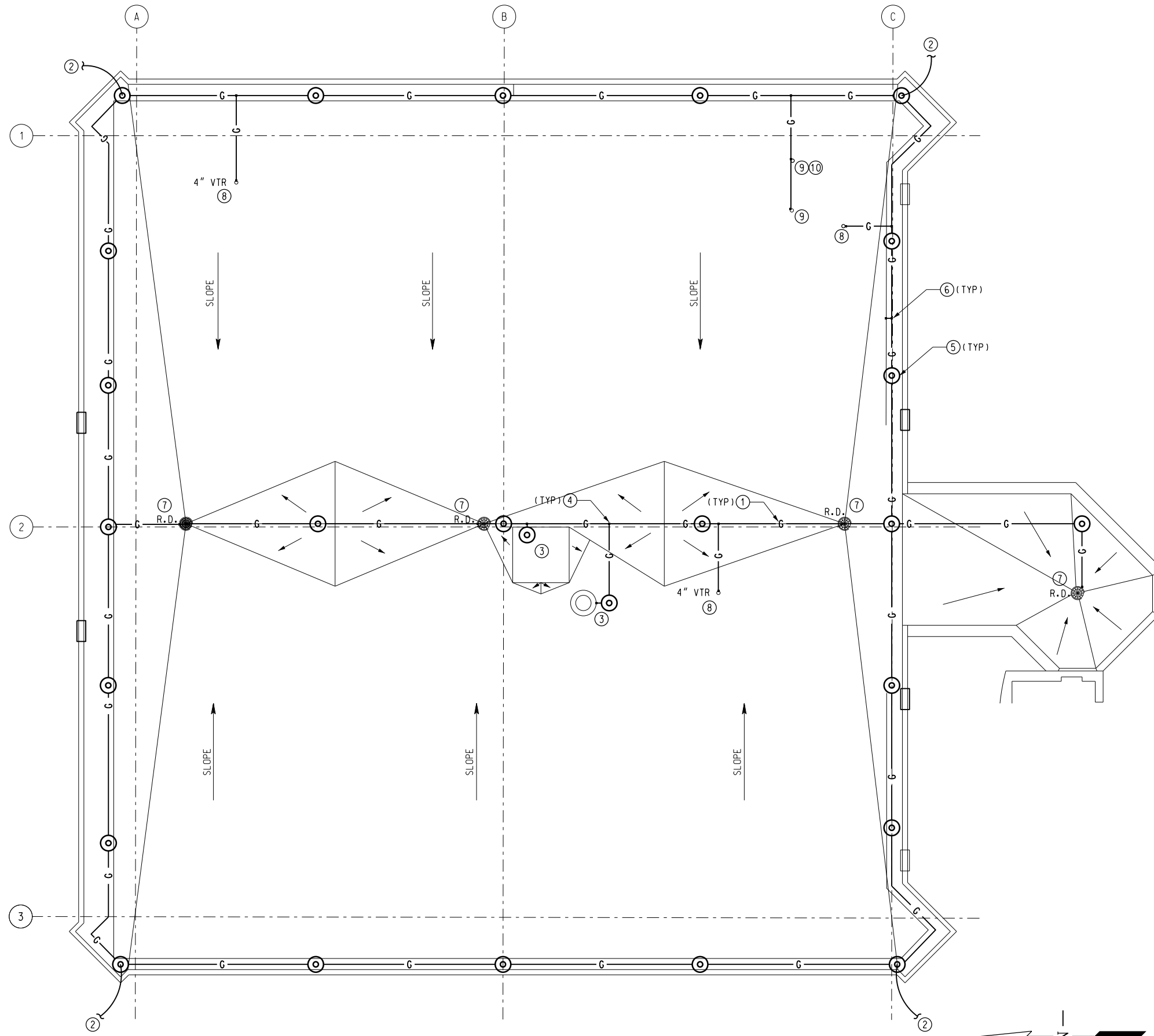

**GENERAL NOTES**

- A. SEE DRAWING TRACO-E000 AND TRACO-E001 FOR ELECTRICAL LEGEND, GENERAL NOTES AND SPECIAL NOTES.
- B. REMOVE EXISTING LIGHTNING PROTECTION ROOF CONDUCTOR AND ACCESSORIES TO FACILITATE ROOF REPLACEMENT. ROOF CONDUCTORS AND BONDS TO BE REPLACED.
- C. ALL BASE BUILDING (TRACON) LIGHTNING PROTECTION SYSTEM CONDUCTOR SHALL BE CLASS II MATERIAL. CONDUCTORS, AIR TERMINALS AND ALL OTHER ACCESSORIES SHALL BE MADE OF COPPER, EXCEPT WHERE DISSIMILAR METALS REQUIRE ALUMINUM. USE BI-METALLIC CONNECTORS AS NEEDED TO CONNECT COPPER AND ALUMINUM MATERIALS.
- D. DOWN CONDUCTOR TERMINATIONS TO THE EES SHALL BE EXOTHERMICALLY WELDED TO A 4/0 AWG COPPER CONDUCTOR PRIOR TO ENTERING THE GROUND AT NOT LESS THAN 18" ABOVE GRADE. THE 4/0 AWG COPPER CONDUCTOR SHALL BE BONDED DIRECTLY TO A GROUND ROD OR ELECTRODE CONDUCTOR IN THE EES (FAA-STD-019F, SECTION 4.3.5.1). DOWN CONDUCTOR CONDUIT SHALL END JUST ABOVE WELDING POINT. PROVIDE AN ACCESSIBLE JUNCTION BOX TO PROTECT WELD. BELOW WELD, BARE CONDUCTOR SHALL RUN INTO THE GROUND TO CONNECT TO COUNTERPOISE.
- E. SUPPORT ROOF CONDUCTOR AT A MIN OF EVERY 3' UTILIZING AN ADHESIVE CABLE CLAMP THOMPSON 186X (OR EQUAL).
- F. TEST AND CONFIRM THAT EXISTING EES RESISTANCE TO GROUND IS LESS THAN 10 OHMS (FAA-STD-019F, SECTION 4.4.3).
- G. CONSULT WITH A LIGHTNING PROTECTION PROFESSIONAL TO PROVIDE TEMPORARY LIGHTNING PROTECTION PROVISIONS DURING CONSTRUCTION.

**KEY NOTES**

- ① CLASS II ROOF CONDUCTOR. THOMPSON 506T OR APPROVED EQUAL.
- ② CLASS II DOWN CONDUCTOR. THOMPSON 506T OR APPROVED EQUAL. BOND DOWN CONDUCTOR TO ROOF CONDUCTOR USING MECHANICAL TERMINATIONS PER DETAIL 1, SHEET TRACO-E601. DOWN CONDUCTORS SHALL EXTEND TO GROUND COUNTERPOISE WITHIN PVC CONDUIT. DOWN CONDUCTORS SHALL FOLLOW THE MOST DIRECT DOWNWARD COURSE, WHILE MAIN AND BONDING CONDUCTORS MUST MAINTAIN A DOWNWARD OR HORIZONTAL COURSE WITH NO BEND LESS THAN 90 DEGREES OR BEND RADIUS LESS THAN 8". ROOF AND DOWN CONDUCTORS SHALL BE FASTENED WITH CABLE HOLDER THOMPSON 186X OR APPROVED EQUAL, AT INTERVALS NOT MORE THAN 3'-0" AND SHALL BE THE SAME MATERIAL AS THE CONDUCTOR. BONDING DEVICES, CONDUCTOR SPLICES, CONDUCTOR ATTACHMENTS, AND CONNECTORS SHALL BE SUITABLE FOR USE WITH THE INSTALLED CONDUCTOR. WHERE DOWN CONDUCTOR ENCOUNTER CANOPY, ROUTE DOWN CONDUCTOR THROUGH 1" PVC SLEEVE. BOND CANOPY TO DOWN CONDUCTORS USING EXOTHERMIC WELD. BOND ALL METALLIC OBJECTS WITHIN 6' OF DOWN CONDUCTORS TO DOWN OR ROOF GROUNDING LOOP TO THE LIGHTNING PROTECTION SYSTEM WITH EXOTHERMIC WELD.
- ③ PROVIDE EXHAUST FAN HOOD EQUIPMENT BOND AND AIR TERMINAL PER DETAIL 3, SHEET TRACO-E600.
- ④ BONDING CONNECTION. SEE BONDING AND SPLICING DETAIL 1, SHEET TRACO-E601.
- ⑤ 24" BLUNT-TIPPED AIR TERMINAL. FREE STANDING TERMINAL SHALL BE MOUNTED TO SUPPORTS PER DETAIL 3, SHEET TRACO-E601.
- ⑥ BONDING JUMPER TO EACH RAILING SECTION. INSTALL AIR TERMINAL TO EACH HANDRAIL WITH TINNED BRONZE PIPE CLAMP PER DETAIL 4/E601.
- ⑦ BOND ROOF CONDUCTOR TO ALL ROOF DRAINS PER DETAIL 1, SHEET TRACO-E600.
- ⑧ BOND ROOF CONDUCTOR TO ALL MECH/PLUMBING VENTS PER DETAIL 2, SHEET TRACO-E600.
- ⑨ BOND COPPER ROOF CONDUCTOR TO EXISTING ANTENNA MOUNT USING CONDUIT GROUND CLAMP PER DETAIL 5, SHEET TRACO-E600.
- ⑩ TENON MOUNTED LIGHT FIXTURES TO BE REPLACED. COORDINATE BONDING WITH FIXTURE INSTALLATION. REFER TO ELECTRICAL SITE PLANS FOR MORE INFORMATION.

**1 BASE BUILDING ROOF & LIGHTNING PROTECTION PLAN**  
 E160 SCALE: 3/16" = 1' - 0"

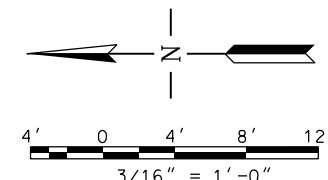

SCALES SHOWN FOR 22" X 34" SHEET. ADJUST SCALES FOR OTHER SIZES.		PAGE	OF
DEPARTMENT OF TRANSPORTATION <b>FEDERAL AVIATION ADMINISTRATION</b>			
<b>FORT LAUDERDALE AIRPORT TRAFFIC CONTROL TOWER          MAJOR IMPROVEMENTS          ELECTRICAL          BASE BUILDING ROOF &amp; LIGHTNING PROTECTION PLAN</b>			
FT LAUDERDALE (INTERNATIONAL)		FL	
REV	APPROVED DATE	DESCRIPTION	JCN REDLINE DATE APVD
REVIEWED BY		SUBMITTED BY	APPROVED BY
DESIGNED BY		ISSUED BY	
DRAWN		ATLANTA TERMINAL ENGINEERING CENTER	
CHECKED		DATE JAN 31, 2020 JCN 1508912	
		DRAWING NO. FLL-D-TRACO-E160	

**Wiley|Wilson**  
 5901 Peachtree Dunwoody Rd.  
 Bldg. C, Ste 515  
 Atlanta, Georgia 30328-6055  
 678.320.1888  
 wileywilson.com  
 WW JOB NUMBER: 219075.00

**GENERAL NOTES:**

- A. CIRCUIT ASSIGNMENTS TO NEW AND EXISTING LOADS ARE USED FOR REFERENCE ONLY. ACTUAL CIRCUIT ASSIGNMENT OF EXISTING LOADS AND AVAILABILITY OF ACTUAL SPARE CIRCUIT BREAKERS AND SPACES AVAILABLE IN EXISTING PANELS SHALL BE FIELD VERIFIED PRIOR TO THE BEGINNING OF NEW CONSTRUCTION.
- B. VERIFY ALL CIRCUITS ON EXISTING PANELS. ADJUST CIRCUITING AS REQUIRED TO MEET DESIGN INTENT ON DRAWINGS. FOR ANY VACATED CIRCUITS, REMOVE CONDUIT AND WIRING BACK TO PANEL, TURN BREAKER OFF, AND MARK BREAKER AS 'SPARE'.
- C. PROVIDE NEW TYPEWRITTEN PANELBOARD DIRECTORY TO INDICATE ACTUAL CIRCUITS USED, UPON COMPLETION OF WORK.
- D. CONTRACTOR SHALL REUSE EXISTING SPARE CIRCUIT BREAKERS OR EXISTING BREAKERS THAT HAVE BECOME AVAILABLE FOLLOWING DEMOLITION. PROVIDE NEW BREAKERS AS REQUIRED WITH TYPE, VOLTAGE RATING, AND AIC RATING MATCHING THE EXISTING BREAKER.

**PANEL SCHEDULE (EXISTING)**

DESIGNATION: <b>NPA</b>		PANEL CHARACTERISTICS											
FED FROM: <b>MDPN</b>		MAIN: <b>225 A MCB</b>		<b>3 PHASE</b>						BUS AMPERAGE: <b>225 AMPS</b>		<b>4 WIRE + GROUND</b>	
LOCATION: <b>STORAGE RM 120</b>		VOLTAGE: <b>120/208 VOLTS</b>		<b>100% NEUTRAL</b>						AIC: <b>EXIST.</b>		MOUNTING: <b>SURFACE</b>	
Branch Circuit Load Description	kVALoads			Trip / Poles	Ckt. No.	Phase	Ckt. No.	Trip / Poles	kVALoads			Branch Circuit Load Description	
	A	B	C						A	B	C		
EF-2				20/1	1	A	2	20/2				UH-8	
SPARE				20/1	3	B	4						
WATER HEATER (EWH-1)				40/2	5	C	6	20/2			1.25	VAV-1 ←	
					7	A	8		1.25				
UH-4				20/2	9	B	10	20/2		1.00		VAV-2 ←	
					11	C	12			1.00			
VAV-3	3.00			40/2	13	A	14	20/2				UH-1	
		3.00			15	B	16						
SPACE					17	C	18	20/2				UH-2	
VAV-4	1.00			20/2	19	A	20						
		1.00			21	B	22	20/2				UH-3	
SPRINKLER CONTROL				20/1	23	C	24						
VAV-5	2.00			30/2	25	A	26	60/3	4.50			VAV-8 ←	
		2.00			27	B	28			4.50			
SPARE				20/1	29	C	30						
SPD				30/3	31	A	32	20/3				BOOSTER PUMPS BP-1 & BP-2	
					33	B	34						
					35	C	36						
SPRINKLER PUMP				20/3	37	A	38	30/3				SUMP PUMP	
					39	B	40						
					41	C	42						
		6.00	6.00	<<PHASE SUB-TOTALS>>					5.75	5.50	2.25		
PHASE TOTALS:		Phase A	Phase B	Phase C									
		11.75	11.50	2.25	kVA								

LOAD SUMMARY (KVA)		
LOAD TYPE	CONNECTED	DEMAND
Lighting		
Receptacles		
UPS		
Equipment: Continuous		
Equipment: Non-Continuous		
Kitchen		
Mechanical: Concurrent	25.50	20.40
Mech: Non-Concurrent		
Supplemental AC		
TOTALS (kVA)	25.50	20.40

**25.50** kVA - TOTAL CONNECTED LOAD  
**20.40** kVA - TOTAL DEMAND LOAD  
**56.62** AMPS - DEMAND

PROVIDE THE FOLLOWING:

**EXISTING DISTRIBUTION BOARD SCHEDULE**

DESIGNATION: <b>MDPE</b>		DISTRIBUTION BOARD CHARACTERISTICS											
FED FROM: <b>MAIN ATS</b>		MAIN: <b>MLO</b>		<b>3 PHASE</b>						BUS AMPERAGE: <b>800 AMPS</b>		<b>4 WIRE + GROUND</b>	
LOCATION: <b>EG BUILDING EG02</b>		VOLTAGE: <b>120/208 VOLTS</b>		<b>100% NEUTRAL</b>						AIC: <b>EXIST.</b>		MOUNTING: <b>SURFACE</b>	
Circuit Number	Load Description	kVALoads			Total kVALoads		Overcurrent Device			Remarks			
		Phase A	Phase B	Phase C	Connected	Demand	Frame	Trip	Poles				
1	PANEL NPA						250	225	3				
2	PANEL NLPA						250	225	3				
3	PANEL ELPT						250	225	3				
4	PANEL NLPTA						250	225	3				
5	PANEL NLPT						250	225	3				
6	PANEL EGPL						250	225	3				
7	PANEL #9						150	125	3				
8	PANEL #10						250	225	3				
9	RR/RT XFMR						150	125	3				
10	PANEL ELPA						150	100	3				
11	UPS STATIC BYPASS						400	400	3				
12	UPS INPUT						400	400	3				
13	UPS MAINT BYPASS						300	300	3				
14	ELEVATOR ATS NORMAL						150	150	3				

PHASE TOTALS: Phase A Phase B Phase C kVA

LOAD SUMMARY (KVA)		
LOAD TYPE	CONNECTED	DEMAND
Lighting		
Receptacles		
UPS		
Equipment: Continuous		
Equipment: Non-Continuous		
Kitchen		
Mechanical: Concurrent		
Mech: Non-Concurrent		
Supplemental AC		
TOTALS (kVA)		

**25.50** kVA - TOTAL CONNECTED LOAD  
**20.40** kVA - TOTAL DEMAND LOAD  
**56.62** AMPS - DEMAND

PROVIDE THE FOLLOWING:

**KEY NOTES:**

- ① REPLACE CIRCUIT BREAKER AND WIRING. CONDUIT TO REMAIN.
- ② CIRCUIT TO BE REPURPOSED. REUSE BREAKER AND CONDUIT. WIRING TO BE REPLACED.

SCALES SHOWN FOR 22" X 34" SHEET. ADJUST SCALES FOR OTHER SIZES. PAGE **OF**

**WileyWilson**  
5901 Peachtree Dunwoody Rd.  
Bldg. C, Ste 515  
Atlanta, Georgia 30328-6055  
678.320.1888  
wileywilson.com  
WW JOB NUMBER: 219075.00

REV	APPROVED DATE	DESCRIPTION	JCN	REDLINE DATE	APVD

**DEPARTMENT OF TRANSPORTATION  
FEDERAL AVIATION ADMINISTRATION**

**FORT LAUDERDALE AIRPORT TRAFFIC CONTROL TOWER  
MAJOR IMPROVEMENTS  
ELECTRICAL  
PANEL SCHEDULES**

FT LAUDERDALE (INTERNATIONAL) FL

REVIEWED BY	SUBMITTED BY	APPROVED BY
SUBMITTER'S TITLE - CIVIL ENGINEER		APPROVER'S TITLE - MANAGER
DESIGNED JMC	ISSUED BY	DATE JAN 31, 2020 JCN 1508912
DRAWN JMC	ATLANTA TERMINAL ENGINEERING CENTER	DRAWING NO
CHECKED MRK		<b>FLL-D-TRACO-E500</b> REV







**GENERAL NOTES:**

- A. CIRCUIT ASSIGNMENTS TO NEW AND EXISTING LOADS ARE USED FOR REFERENCE ONLY. ACTUAL CIRCUIT ASSIGNMENT OF EXISTING LOADS AND AVAILABILITY OF ACTUAL SPARE CIRCUIT BREAKERS AND SPACES AVAILABLE IN EXISTING PANELS SHALL BE FIELD VERIFIED PRIOR TO THE BEGINNING OF NEW CONSTRUCTION.
- B. VERIFY ALL CIRCUITS ON EXISTING PANELS. ADJUST CIRCUITING AS REQUIRED TO MEET DESIGN INTENT ON DRAWINGS. FOR ANY VACATED CIRCUITS, REMOVE CONDUIT AND WIRING BACK TO PANEL, TURN BREAKER OFF, AND MARK BREAKER AS 'SPARE'.
- C. PROVIDE NEW TYPEWRITTEN PANELBOARD DIRECTORY TO INDICATE ACTUAL CIRCUITS USED, UPON COMPLETION OF WORK.
- D. CONTRACTOR SHALL REUSE EXISTING SPARE CIRCUIT BREAKERS OR EXISTING BREAKERS THAT HAVE BECOME AVAILABLE FOLLOWING DEMOLITION. PROVIDE NEW BREAKERS AS REQUIRED WITH TYPE, VOLTAGE RATING, AND AIC RATING MATCHING THE EXISTING BREAKER.

**KEY NOTES:**

- ① USE EXISTING SPARE BREAKER IN PANEL FOR NEW DDC CONTROL PANEL CIRCUIT.

PANEL SCHEDULE (EXISTING)												
DESIGNATION: #9						PANEL CHARACTERISTICS						
FED FROM: MDPE						MAIN: MLO 3 PHASE						
LOCATION: STORAGE RM 120						BUS AMPERAGE: 125 AMPS 4 WIRE + GROUND						
						VOLTAGE: 120/208 VOLTS 100% NEUTRAL						
						AIC: EXIST. MOUNTING: SURFACE						
Branch Circuit Load Description	kVA Loads			Trip / Poles	Ckt. No.	Phase	Ckt. No.	Trip / Poles	kVA Loads			Branch Circuit Load Description
	A	B	C						A	B	C	
HP-2				70/3	1	A	2	30/1				SPACE
					3	B	4	20/1				SPACE
					5	C	6	20/1				SPACE
HP-1				70/3	7	A	8	30/3				SPD
					9	B	10					
					11	C	12					
FUEL LEVEL INDICATOR				20/1	13	A	14	20/1				FACP
FUEL LEVEL INDICATOR				20/1	15	B	16	20/1				FSD-2
SPARE				20/1	17	C	18	20/1				SPARE
SPARE				20/1	19	A	20	20/1				EXIT LIGHTS
FSD-1				20/1	21	B	22	20/1	0.50			DDC CONTROL PANEL ①
SPARE				20/1	23	C	24	20/1				SPARE
SPARE				20/1	25	A	26	20/1				SPARE
SPARE				20/1	27	B	28	20/1				SPARE
SPARE				20/1	29	C	30	20/1				SPARE
SPACE					31	A	32					SPACE
SPACE					33	B	34					SPACE
SPACE					35	C	36					SPACE
SPACE					37	A	38					SPACE
SPACE					39	B	40					SPACE
SPACE					41	C	42					SPACE
<<PHASE SUB-TOTALS>>									0.50			
PHASE TOTALS:			Phase A	Phase B	Phase C							
				0.50		kVA						

LOAD SUMMARY (KVA)		
LOAD TYPE	CONNECTED	DEMAND
Lighting		
Receptacles		
UPS		
Equipment: Continuous	0.50	0.40
Equipment: Non-Continuous		
Kitchen		
Mechanical: Concurrent		
Mech: Non-Concurrent		
Supplemental AC		
<b>TOTALS (kVA)</b>	<b>0.50</b>	<b>0.40</b>

<b>0.50</b> kVA - TOTAL CONNECTED LOAD	<b>PROVIDE THE FOLLOWING:</b>
<b>0.40</b> kVA - TOTAL DEMAND LOAD	
<b>1.11</b> AMPS - DEMAND	

PANEL SCHEDULE (EXISTING)												
DESIGNATION: #10						PANEL CHARACTERISTICS						
FED FROM: MDPE						MAIN: MLO 3 PHASE						
LOCATION: STORAGE RM 120						BUS AMPERAGE: 250 AMPS 4 WIRE + GROUND						
						VOLTAGE: 120/208 VOLTS 100% NEUTRAL						
						AIC: EXIST. MOUNTING: SURFACE						
Branch Circuit Load Description	kVA Loads			Trip / Poles	Ckt. No.	Phase	Ckt. No.	Trip / Poles	kVA Loads			Branch Circuit Load Description
	A	B	C						A	B	C	
CU-1 CONV. RECPT.				20/1	1	A	2	150/3				CU-1
VAV-9		1.00		20/2	3	B	4					
			1.00		5	C	6					
GATE				20/2	7	A	8	20/2				GATE
					9	B	10					
SPARE				20/1	11	C	12	20/1				SPARE
SPARE				20/1	13	A	14	20/1				SPARE
LIGHTING				50/2	15	B	16	20/1				SPARE
					17	C	18	20/1				SPARE
SPARE				30/3	19	A	20	30/3				SPD
					21	B	22					
					23	C	24					
RWSL				30/1	25	A	26	20/1				SPARE
RWSL				15/1	27	B	28					SPACE
SPACE					29	C	30					SPACE
SPACE					31	A	32					SPACE
SPACE					33	B	34					SPACE
SPACE					35	C	36					SPACE
SPACE					37	A	38					SPACE
SPACE					39	B	40					SPACE
SPACE					41	C	42					SPACE
<<PHASE SUB-TOTALS>>									1.00	1.00		
PHASE TOTALS:			Phase A	Phase B	Phase C							
				1.00	1.00	kVA						

  

LOAD SUMMARY (KVA)		
LOAD TYPE	CONNECTED	DEMAND
Lighting		
Receptacles		
UPS		
Equipment: Continuous		
Equipment: Non-Continuous		
Kitchen		
Mechanical: Concurrent	36.80	29.44
Mech: Non-Concurrent		
Supplemental AC		
<b>TOTALS (kVA)</b>	<b>36.80</b>	<b>29.44</b>

<b>36.80</b> kVA - TOTAL CONNECTED LOAD	<b>PROVIDE THE FOLLOWING:</b>
<b>29.44</b> kVA - TOTAL DEMAND LOAD	
<b>81.72</b> AMPS - DEMAND	

SCALES SHOWN FOR 22" X 34" SHEET. ADJUST SCALES FOR OTHER SIZES.				PAGE	OF
					
REV	APPROVED DATE	DESCRIPTION	JCN	REDLINE DATE	APVD
DEPARTMENT OF TRANSPORTATION FEDERAL AVIATION ADMINISTRATION  FORT LAUDERDALE AIRPORT TRAFFIC CONTROL TOWER MAJOR IMPROVEMENTS ELECTRICAL PANEL SCHEDULES					
FT LAUDERDALE (INTERNATIONAL)			FL		
REVIEWED BY	SUBMITTED BY	APPROVED BY			
SUBMITTER'S TITLE - CIVIL ENGINEER		APPROVER'S TITLE - MANAGER			
DESIGNED	JMC	ISSUED BY	DATE	JCN	REV
DRAWN	JMC	ATLANTA TERMINAL ENGINEERING CENTER	JAN 31, 2020	1508912	
CHECKED	MRK	DRAWING NO. <b>FLL-D-TRACO-E502</b>			
WILEY WILSON 5901 Peachtree Dunwoody Rd. Bldg. C, Ste 515 Atlanta, Georgia 30328-6055 678.320.1888 wileywilson.com  WW JOB NUMBER: 219075.00					

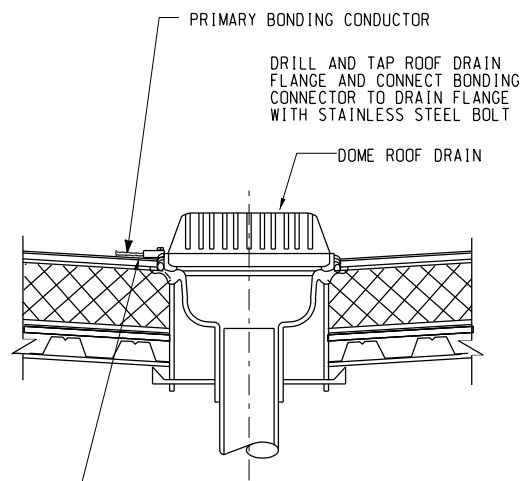

THOMPSON #551 BONDING LUG WITH 3/8" BOLT HOLE

1 ROOF DRAIN GROUNDING  
E600 NOT TO SCALE

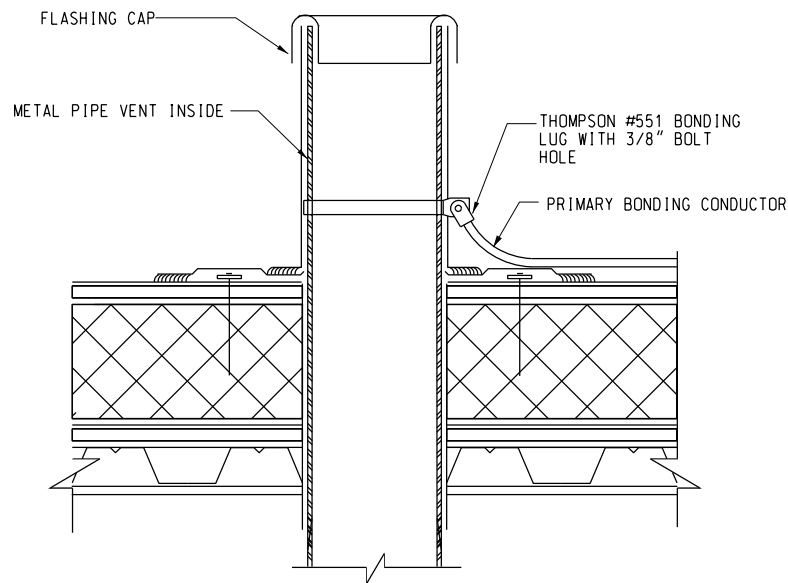

2 ROOF VENT GROUNDING  
E600 NOT TO SCALE

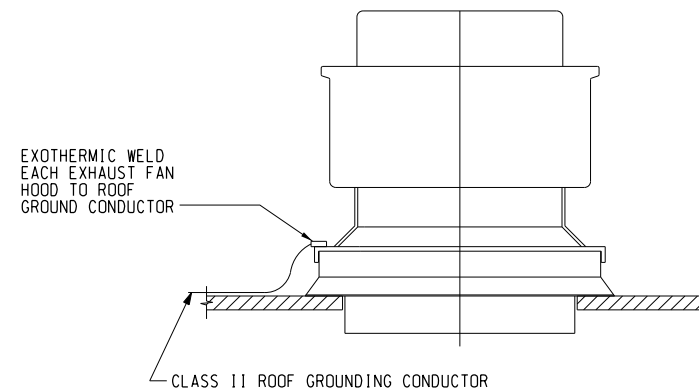

3 EXHAUST FAN HOOD GROUNDING  
E600 NOT TO SCALE

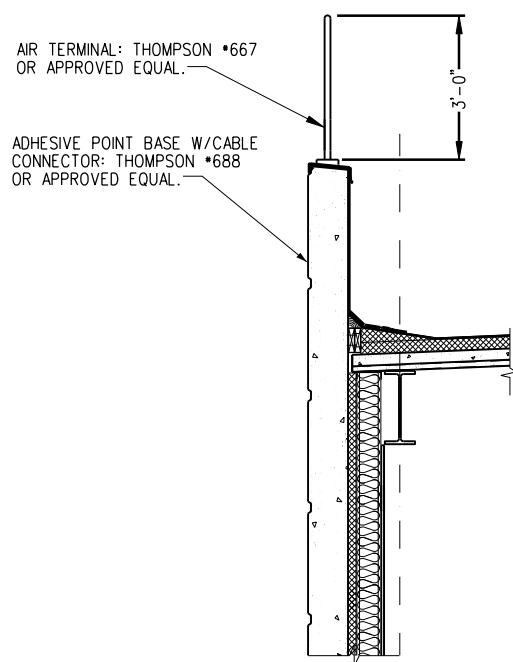

4 PARAPET ROOF AIR TERMINAL  
E600 NOT TO SCALE

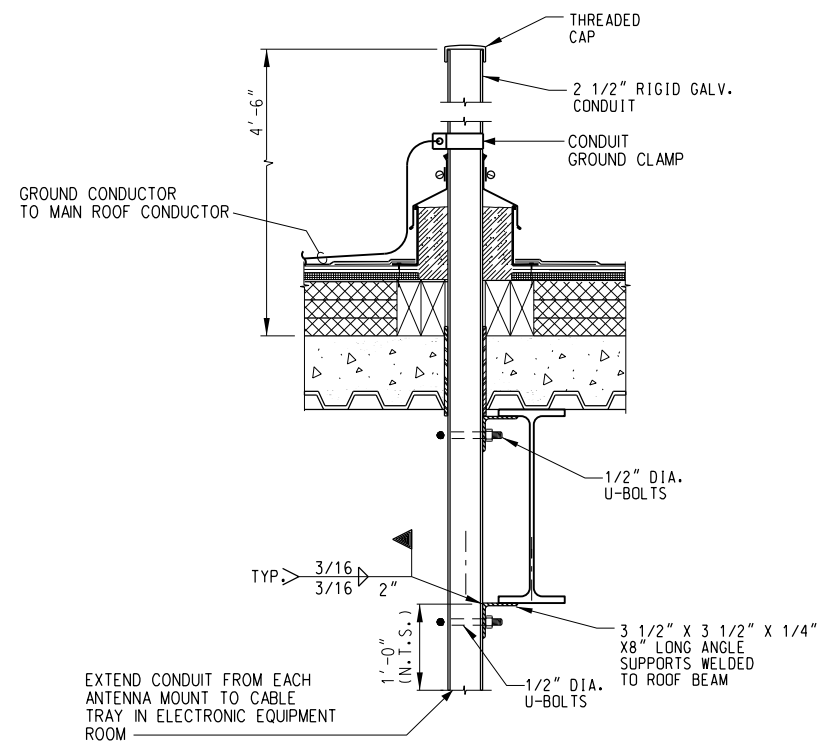

5 ANTENNA MOUNT DETAIL  
E600 NOT TO SCALE

SCALES SHOWN FOR 22" X 34" SHEET. ADJUST SCALES FOR OTHER SIZES. PAGE OF

REV	APPROVED DATE	DESCRIPTION	JCN	REDLINE DATE	APVD

DEPARTMENT OF TRANSPORTATION  
FEDERAL AVIATION ADMINISTRATION

FORT LAUDERDALE AIRPORT TRAFFIC CONTROL TOWER  
MAJOR IMPROVEMENTS  
ELECTRICAL  
DETAILS

FT LAUDERDALE (INTERNATIONAL) FL

REVIEWED BY	SUBMITTED BY	APPROVED BY
DESIGNED	JMC	ISSUED BY
DRAWN	CRK	ATLANTA TERMINAL ENGINEERING CENTER
CHECKED	MAK	

DATE JAN 31, 2020 JCN 1508912  
DRAWING NO FLL-D-TRACO-E600 REV

**WileyWilson**  
5901 Peachtree Dunwoody Rd.  
Bldg. C, Ste 515  
Atlanta, Georgia 30328-6055  
678.320.1888  
wileywilson.com  
WW JOB NUMBER: 219075.00

**GEORGIA REGISTERED PROFESSIONAL ENGINEER**  
No. 044833  
BRIONA R. PERRY

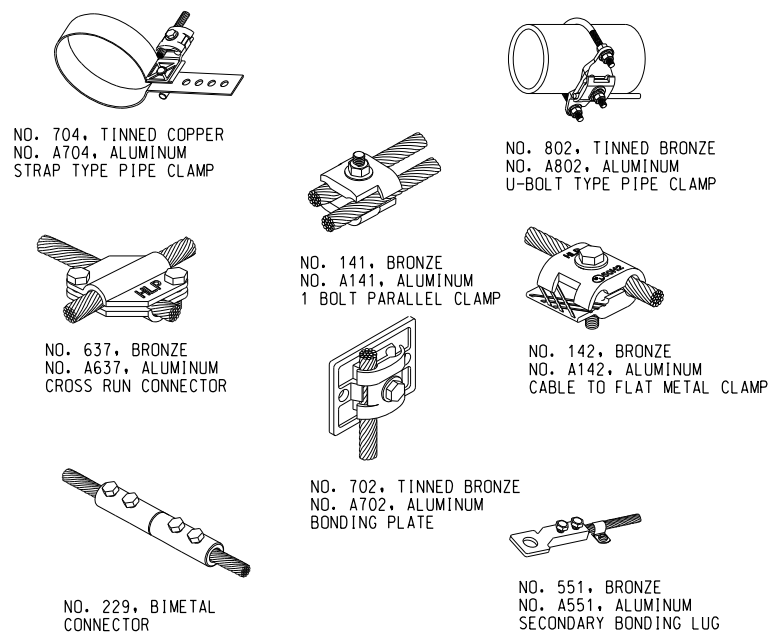

1 TYPICAL BONDING/SPLICING DETAILS  
E601 NOT TO SCALE

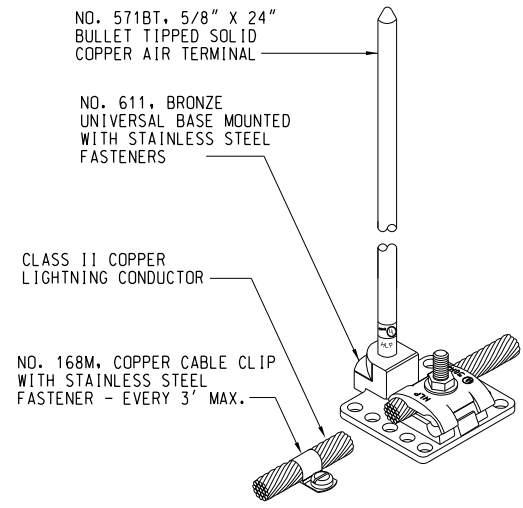

2 AIR TERMINAL DETAIL  
E601 NOT TO SCALE

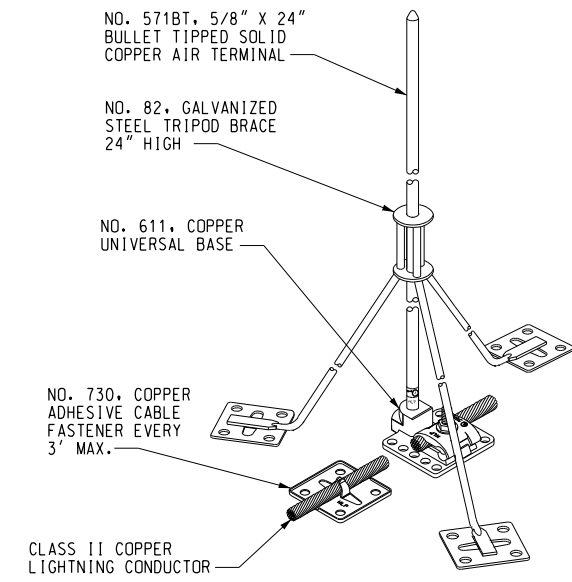

3 AIR TERMINAL DETAIL  
E601 NOT TO SCALE

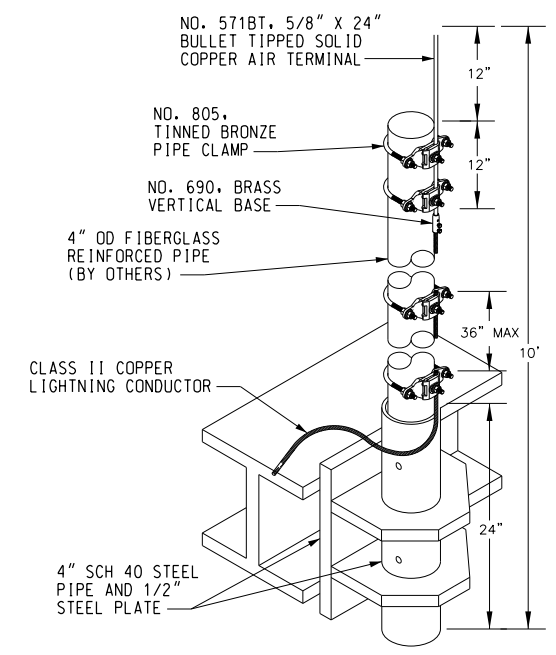

4 AIR TERMINAL DETAIL  
E601 NOT TO SCALE

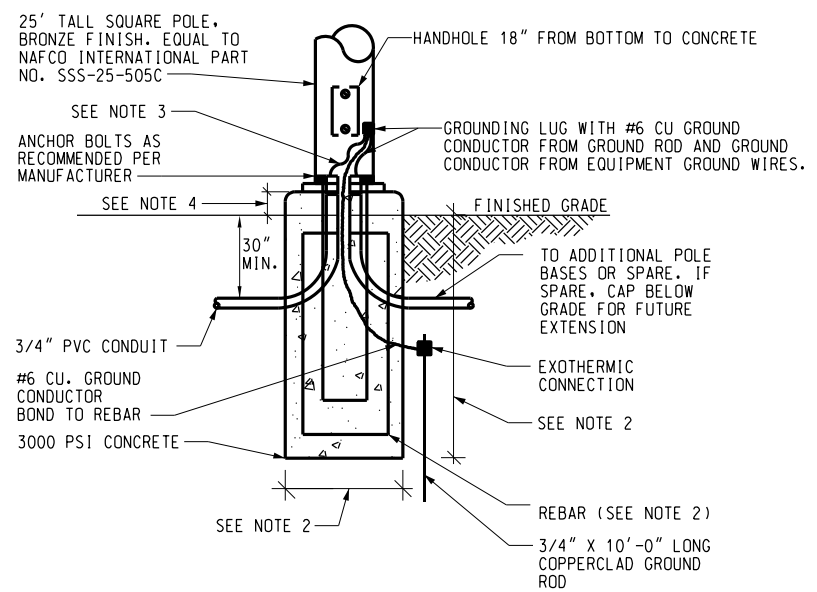

- NOTES:
- FURNISH POLE BASE TEMPLATE TO GENERAL CONTRACTOR PRIOR TO CONCRETE POUR.
  - POLE BASE SHALL BE 8'-0" IN DEPTH, 2'-0" DIAMETER WIDTH. PROVIDE #3 HORIZONTAL BARS AT 12" ON CENTER. PROVIDE 6-#6 VERTICAL BARS EQUALLY SPACED.
  - PROVIDE GROUNDING BUSHINGS PER NEC.
  - SET TOP OF CONCRETE FOUNDATION 4" ABOVE GRADE.

5 POLE BASE DETAIL  
E601 NOT TO SCALE

SCALES SHOWN FOR 22" X 34" SHEET. ADJUST SCALES FOR OTHER SIZES. PAGE OF

REV	APPROVED DATE	DESCRIPTION	JCN	REDLINE DATE	APVD
DEPARTMENT OF TRANSPORTATION FEDERAL AVIATION ADMINISTRATION FORT LAUDERDALE AIRPORT TRAFFIC CONTROL TOWER MAJOR IMPROVEMENTS ELECTRICAL DETAILS					
FT LAUDERDALE		(INTERNATIONAL)	FL		
REVIEWED BY	SUBMITTED BY	APPROVED BY			
DESIGNED	JMC	SUBMITTER'S TITLE - CIVIL ENGINEER	APPROVER'S TITLE - MANAGER		
DRAWN	JMC	ISSUED BY	DATE	JCN	
CHECKED	JAB	ATLANTA TERMINAL ENGINEERING CENTER	JAN 31, 2020	1508912	
WILEY WILSON		FLL-D-TRACO-E601			

WILEY|WILSON  
5901 Peachtree Dunwoody Rd.  
Bldg. C, Ste 515  
Atlanta, Georgia 30328-6055  
678.320.1888  
wileywilson.com  
WW JOB NUMBER: 219075.00

GEORGIA REGISTERED PROFESSIONAL ENGINEER  
BRIGIDA R. PERRY  
1/31/2020  
No. 044833

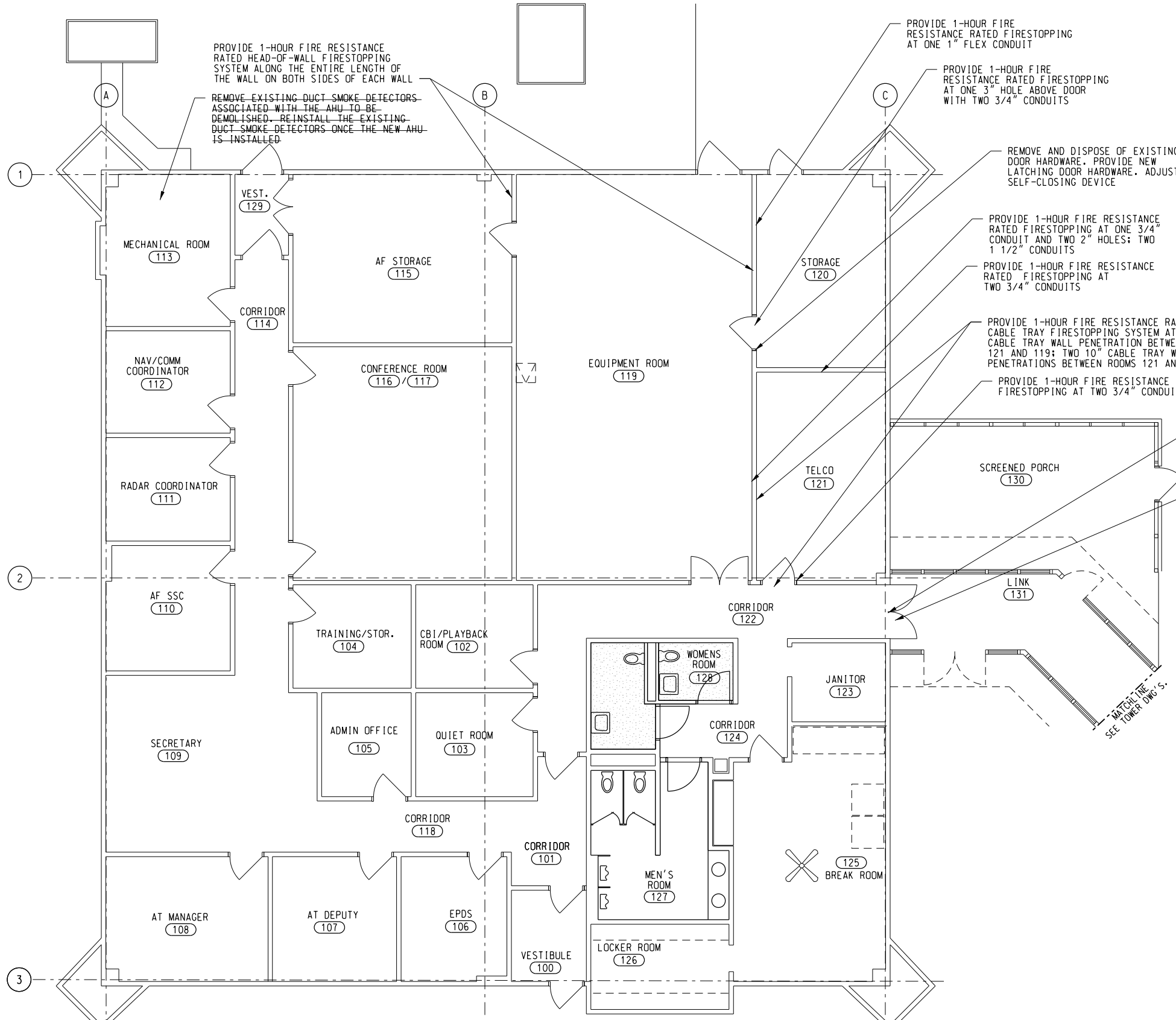

PROVIDE 1-HOUR FIRE RESISTANCE RATED HEAD-OF-WALL FIRESTOPPING SYSTEM ALONG THE ENTIRE LENGTH OF THE WALL ON BOTH SIDES OF EACH WALL

REMOVE EXISTING DUCT SMOKE DETECTORS ASSOCIATED WITH THE AHU TO BE DEMOLISHED. REINSTALL THE EXISTING DUCT SMOKE DETECTORS ONCE THE NEW AHU IS INSTALLED.

PROVIDE 1-HOUR FIRE RESISTANCE RATED FIRESTOPPING AT ONE 1" FLEX CONDUIT

PROVIDE 1-HOUR FIRE RESISTANCE RATED FIRESTOPPING AT ONE 3" HOLE ABOVE DOOR WITH TWO 3/4" CONDUITS

REMOVE AND DISPOSE OF EXISTING DOOR HARDWARE. PROVIDE NEW LATCHING DOOR HARDWARE. ADJUST SELF-CLOSING DEVICE

PROVIDE 1-HOUR FIRE RESISTANCE RATED FIRESTOPPING AT ONE 3/4" CONDUIT AND TWO 2" HOLES; TWO 1 1/2" CONDUITS

PROVIDE 1-HOUR FIRE RESISTANCE RATED FIRESTOPPING AT TWO 3/4" CONDUITS

PROVIDE 1-HOUR FIRE RESISTANCE RATED CABLE TRAY FIRESTOPPING SYSTEM AT THE 10" CABLE TRAY WALL PENETRATION BETWEEN ROOMS 121 AND 119; TWO 10" CABLE TRAY WALL PENETRATIONS BETWEEN ROOMS 121 AND 122

PROVIDE 1-HOUR FIRE RESISTANCE RATED FIRESTOPPING AT TWO 3/4" CONDUITS

PROVIDE 2-HOUR FIRE RESISTANCE RATED CABLE TRAY FIRESTOPPING SYSTEM AT THE 26" CABLE TRAY WALL PENETRATION. PROVIDE 2-HOUR FIRE RESISTANCE RATED FIRESTOPPING AT ONE 2" CONDUIT AND FOUR 3/4" CONDUITS

CONNECT THE NEW FIRE/SMOKE DAMPER ACTUATOR TO THE EXISTING FIRE ALARM RELAY. SEE ELECTRICAL DRAWINGS FOR FIRE/SMOKE DAMPER ACTUATOR INFORMATION

SWITCHING SEE TOWER DWG 5.

**NOTES**

1. ALL INTERIOR WALLS, CEILINGS, FLOORS, DOORS AND OTHER FINISHED CONSTRUCTION THAT ARE DAMAGED OR ALTERED BY THE CONTRACTOR SHALL BE RESTORED TO ORIGINAL CONDITION.
2. PRIOR TO ANY FIRESTOPPING MATERIALS OR ASSEMBLY BEING INSTALLED, THE CONTRACTOR SHALL HAVE SUBMITTED TO THE FAA RESIDENT ENGINEER MSDS OF ALL MATERIALS INTENDED FOR USE. NO SUBSTITUTIONS SHALL BE PERMITTED WITHOUT THE WRITTEN PERMISSION OF THE RESIDENT ENGINEER. REFER TO SPECIFICATION SECTION 07840 FOR APPROVED FIRESTOPPING MATERIALS AND METHODS.
3. PROVIDE UL-LISTED ASSEMBLIES OR ENGINEERED SYSTEMS FOR ALL FIRE BARRIER AND FIRESTOPPING APPLICATIONS AT ALL REQUIRED LOCATIONS. FIRESTOPPING IS ALSO REQUIRED FOR ALL PENETRATIONS MADE BY THE CONTRACTOR FOR ALL DEMO AND NEW WORK. UL CLASSIFICATION PRODUCT DATA SHEET OR MANUFACTURER'S ENGINEERED SYSTEM SHALL BE SUBMITTED AND APPROVED BEFORE ANY FIRESTOPPING IS INSTALLED.

**1 BASE BUILDING PLAN**  
F101 SCALE: 3/16" = 1'-0"

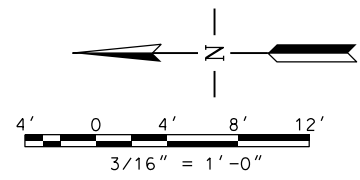

SCALES SHOWN FOR 22" X 34" SHEET. ADJUST SCALES FOR OTHER SIZES. PAGE OF



**Wiley|Wilson**  
5901 Peachtree Dunwoody Rd.  
Bldg. C, Ste 515  
Atlanta, Georgia 30328-6055  
678.320.1888  
wileywilson.com  
WW JOB NUMBER: 219075.00

REV	APPROVED DATE	DESCRIPTION	JCN	REDLINE DATE	APVD
DEPARTMENT OF TRANSPORTATION <b>FEDERAL AVIATION ADMINISTRATION</b>					
<b>FORT LAUDERDALE AIRPORT TRAFFIC CONTROL TOWER</b> <b>MAJOR IMPROVEMENTS</b> <b>BASE BUILDING AND LINK PLAN</b>					
FT LAUDERDALE		(INTERNATIONAL)		FL	
REVIEWED BY	SUBMITTED BY	APPROVED BY			
SUBMITTER'S TITLE - CIVIL ENGINEER		APPROVER'S TITLE - MANAGER			
DESIGNED	JWJ	ISSUED BY	DATE	JCN	1508912
DRAWN	HJM	ATLANTA TERMINAL ENGINEERING CENTER	DRAWING NO		
CHECKED	JWJ	FLL-D-TRACO-F101			

**NOTES**

1. ALL INTERIOR WALLS, CEILINGS, FLOORS, DOORS AND OTHER FINISHED CONSTRUCTION THAT ARE DAMAGED OR ALTERED BY THE CONTRACTOR SHALL BE RESTORED TO ORIGINAL CONDITION.
2. PRIOR TO ANY FIRESTOPPING MATERIALS OR ASSEMBLY BEING INSTALLED, THE CONTRACTOR SHALL HAVE SUBMITTED TO THE FAA RESIDENT ENGINEER MSDS OF ALL MATERIALS INTENDED FOR USE. NO SUBSTITUTIONS SHALL BE PERMITTED WITHOUT THE WRITTEN PERMISSION OF THE RESIDENT ENGINEER. REFER TO SPECIFICATION SECTION 07840 FOR APPROVED FIRESTOPPING MATERIALS AND METHODS.
3. PROVIDE UL-LISTED ASSEMBLIES OR ENGINEERED SYSTEMS FOR ALL FIRE BARRIER AND FIRESTOPPING APPLICATIONS AT ALL REQUIRED LOCATIONS. FIRESTOPPING IS ALSO REQUIRED FOR ALL PENETRATIONS MADE BY THE CONTRACTOR FOR ALL DEMO AND NEW WORK. UL CLASSIFICATION PRODUCT DATA SHEET OR MANUFACTURER'S ENGINEERED SYSTEM SHALL BE SUBMITTED AND APPROVED BEFORE ANY FIRESTOPPING IS INSTALLED.

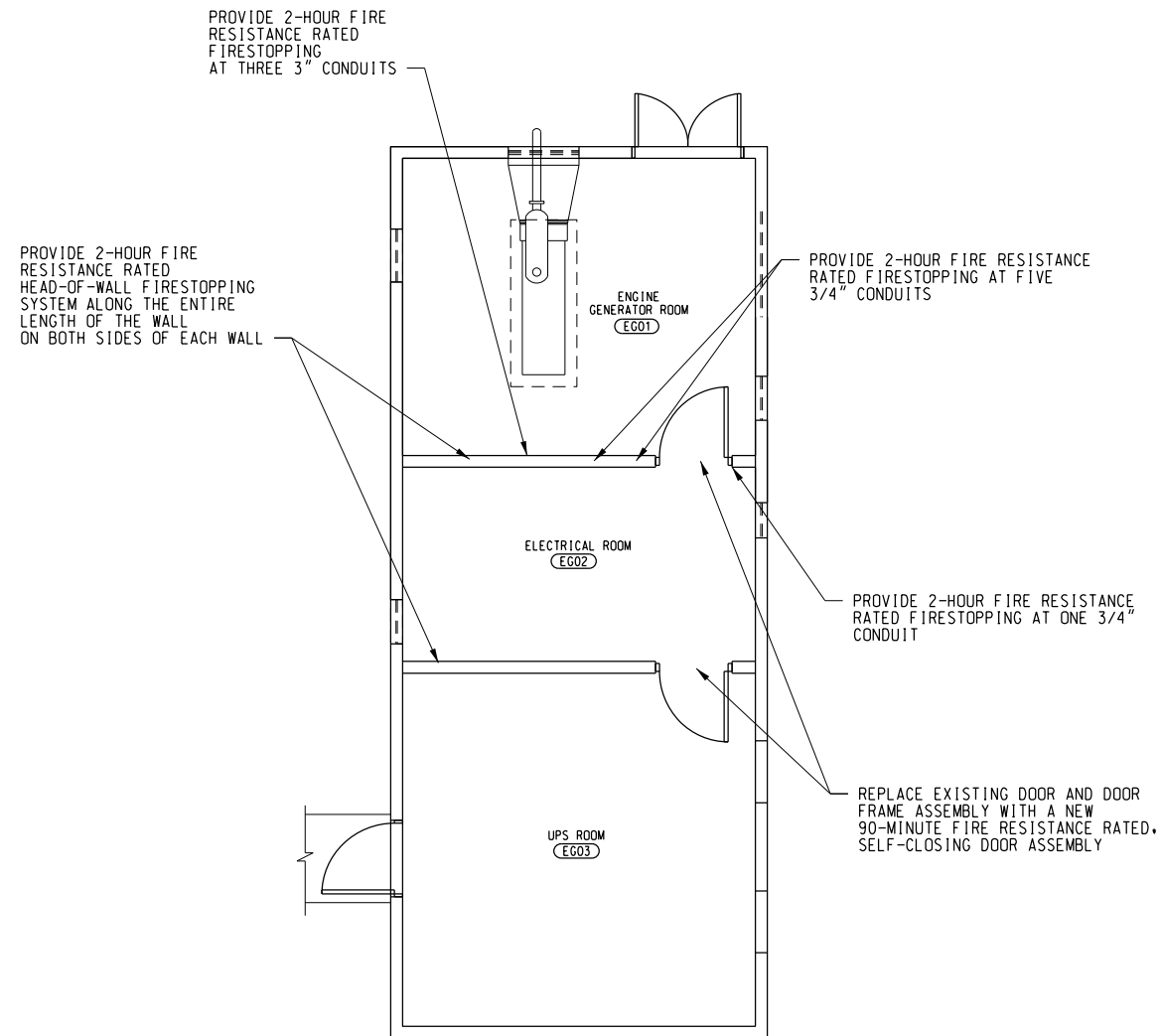

**1** GENERATOR BUILDING PLAN  
 F102 SCALE: 3/16" = 1'-0"

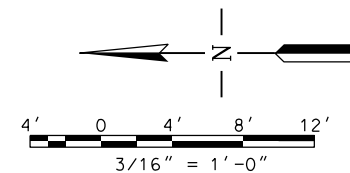

SCALES SHOWN FOR 22" X 34" SHEET. ADJUST SCALES FOR OTHER SIZES.				PAGE	OF
					
DEPARTMENT OF TRANSPORTATION <b>FEDERAL AVIATION ADMINISTRATION</b>					
FORT LAUDERDALE AIRPORT TRAFFIC CONTROL TOWER MAJOR IMPROVEMENTS <b>GENERATOR BUILDING PLAN</b>					
FT LAUDERDALE		(INTERNATIONAL)		FL	
REVIEWED BY	SUBMITTED BY	APPROVED BY			
		SUBMITTER'S TITLE - CIVIL ENGINEER		APPROVER'S TITLE - MANAGER	
DESIGNED	JWJ	ISSUED BY		DATE	JAN 31, 2020
DRAWN	HJM	ATLANTA TERMINAL ENGINEERING CENTER		JCN	1508912
CHECKED	JWJ	DRAWING NO		FLL-D-TRACO-F102	
WW JOB NUMBER: 219075.00					



NOTES

1. REMOVE EXISTING 3" ROOF/STORM DRAIN PIPE. REFER TO ATCT-D400 FOR PLUMBING DEMOLITION.

**What sizes are these doors? How are they currently attached? Saw cutting required?**

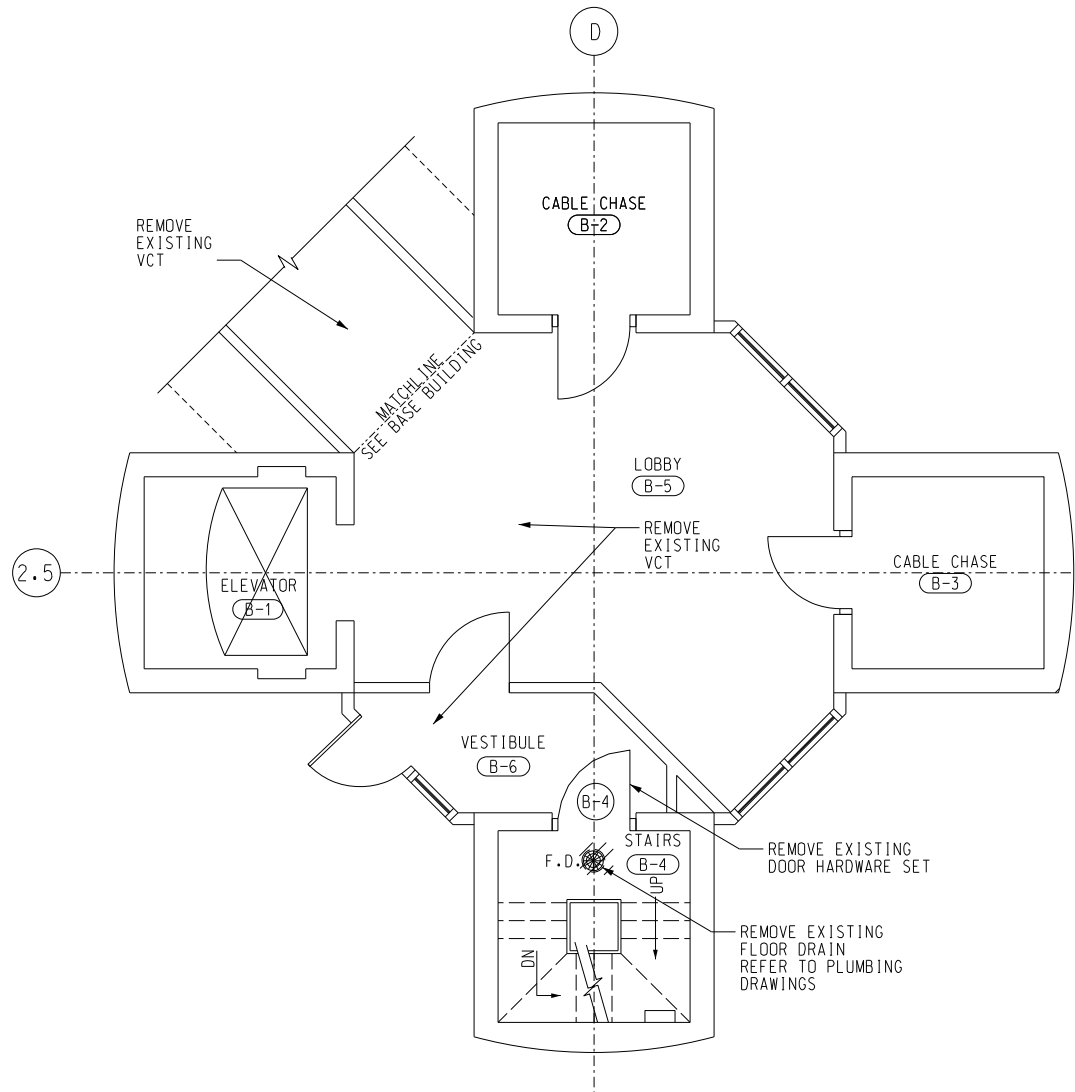

**1** GROUND LEVEL DEMOLITION PLAN  
D100 SCALE: 1/4" = 1' - 0"

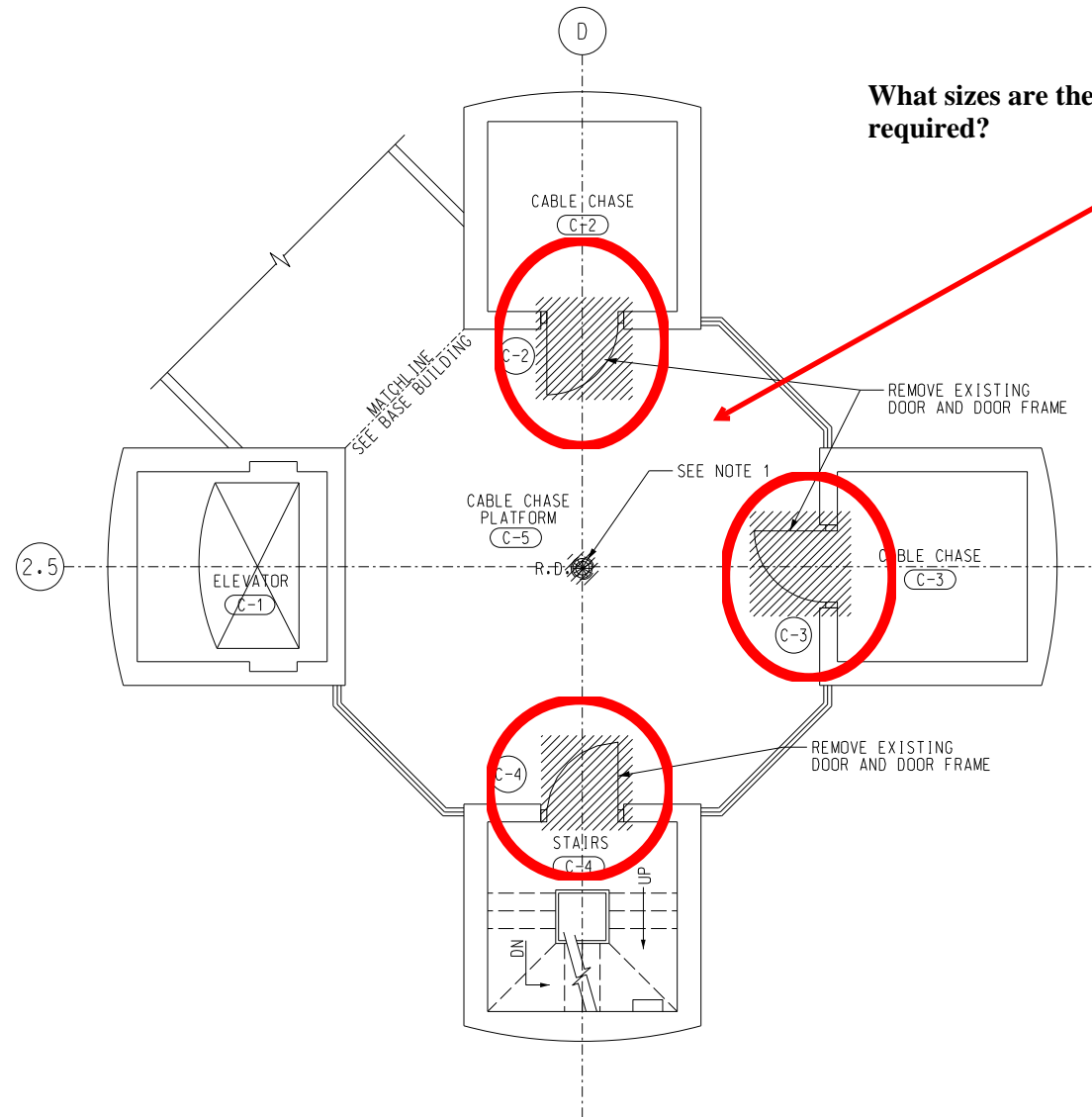

**2** SECOND LEVEL DEMOLITION PLAN  
D100 SCALE: 1/4" = 1' - 0"

NO WORK TO BE DONE ON THIS LEVEL

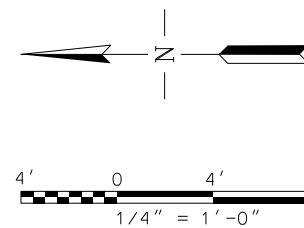

SCALES SHOWN FOR 22" X 34" SHEET. ADJUST SCALES FOR OTHER SIZES.		PAGE	OF
		REV	APPROVED DATE
		DESCRIPTION	JCN
DEPARTMENT OF TRANSPORTATION FEDERAL AVIATION ADMINISTRATION  FORT LAUDERDALE AIRPORT TRAFFIC CONTROL TOWER MAJOR IMPROVEMENTS ARCHITECTURAL GROUND LEVEL AND SECOND LEVEL DEMOLITION FT LAUDERDALE (INTERNATIONAL) FL		REVISION	APPROVED DATE
REVIEWED BY	SUBMITTED BY	APPROVED BY	
DESIGNED	GMR	SUBMITTER'S TITLE - CIVIL ENGINEER	APPROVER'S TITLE - MANAGER
DRAWN	GMR	ISSUED BY	DATE JAN 31, 2020 JCN 1508912
CHECKED	NXE	ATLANTA TERMINAL ENGINEERING CENTER	DRAWING NO. FLL-D-ATCT-D100





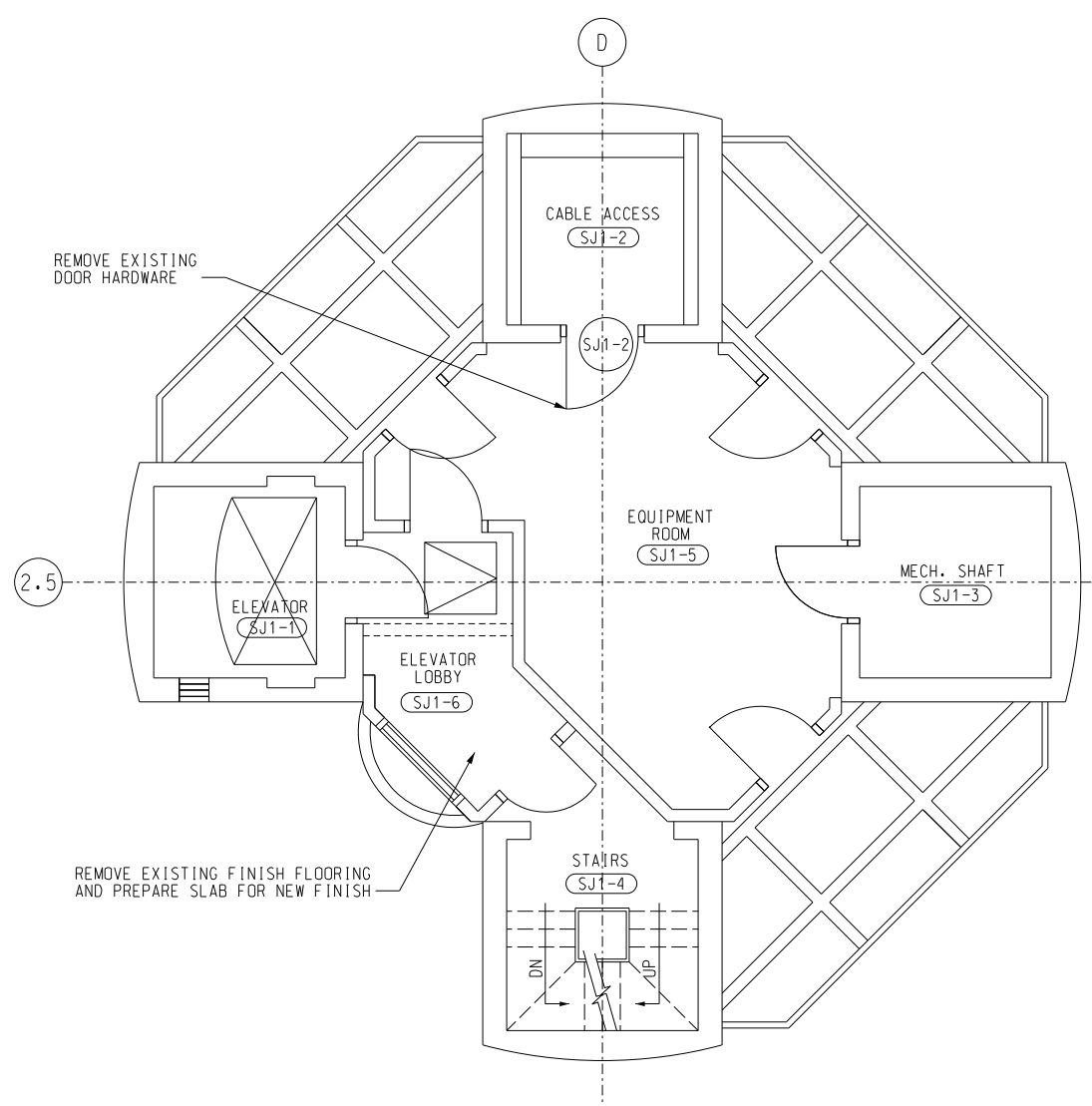

1 SUBJUNCTION LEVEL 1 DEMOLITION PLAN  
 D102 SCALE: 1/4" = 1' - 0"

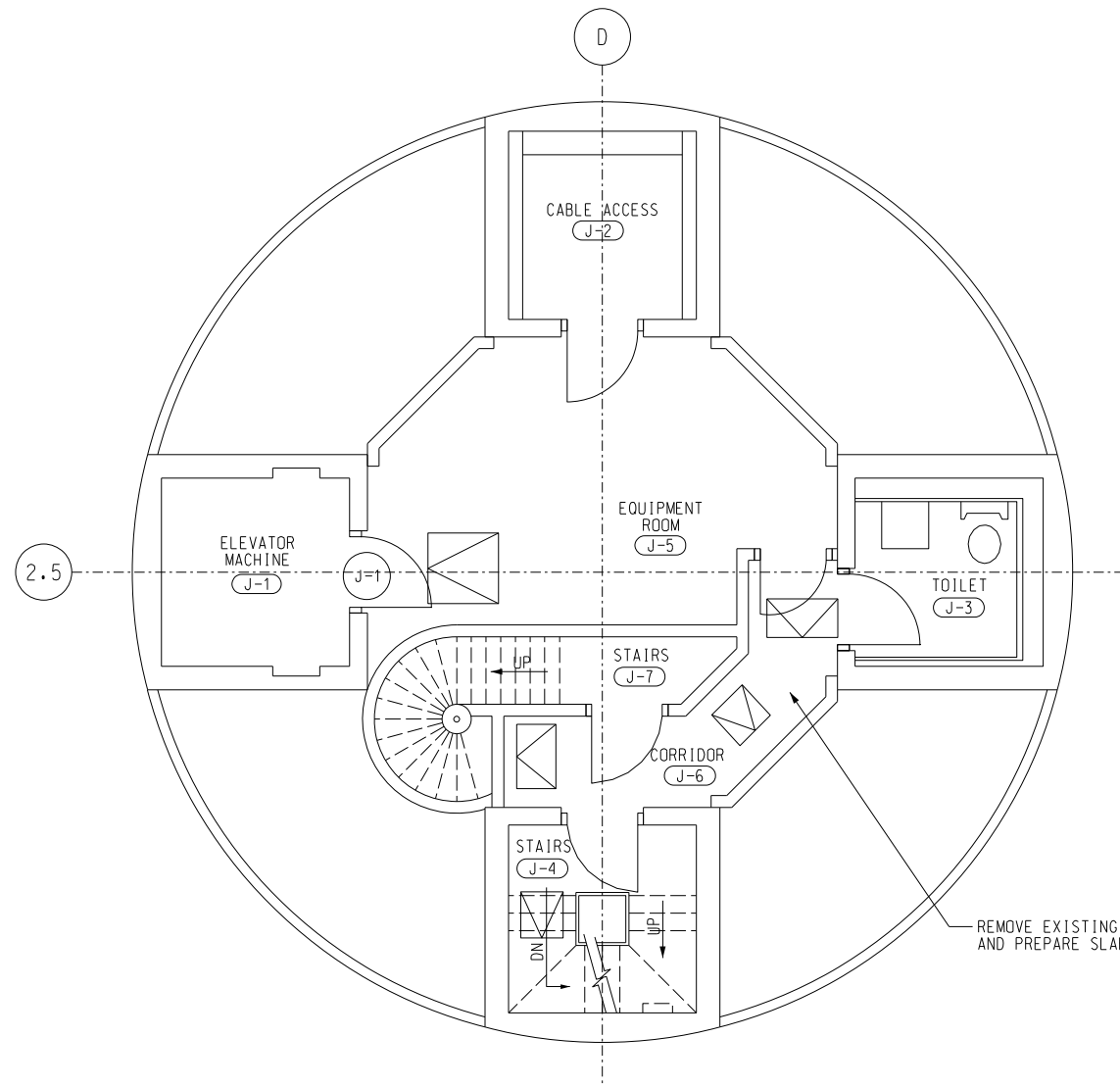

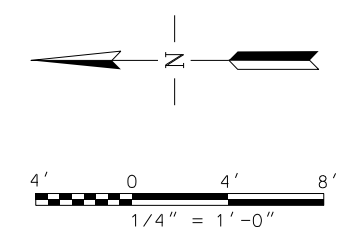

2 JUNCTION LEVEL DEMOLITION PLAN  
 D102 SCALE: 1/4" = 1' - 0"



SCALES SHOWN FOR 22" X 34" SHEET. ADJUST SCALES FOR OTHER SIZES. PAGE OF

REV	APPROVED DATE	DESCRIPTION	JCN	REDLINE DATE	APVD





**WileyWilson**  
 5901 Peachtree Dunwoody Rd.  
 Bldg. C, Ste 515  
 Atlanta, Georgia 30328-6055  
 678.320.1888  
 wileywilson.com  
 WW JOB NUMBER: 219075.00

DEPARTMENT OF TRANSPORTATION  
 FEDERAL AVIATION ADMINISTRATION  
 FORT LAUDERDALE AIRPORT TRAFFIC CONTROL TOWER  
 MAJOR IMPROVEMENTS  
 ARCHITECTURAL  
 SUBJUNCTION LEVEL 1 AND JUNCTION LEVEL DEMOLITION  
 FT LAUDERDALE (INTERNATIONAL) FL

REVIEWED BY	SUBMITTED BY	APPROVED BY
DESIGNED	GMR	ISSUED BY
DRAWN	GMR	ATLANTA TERMINAL ENGINEERING CENTER
CHECKED	MDS	

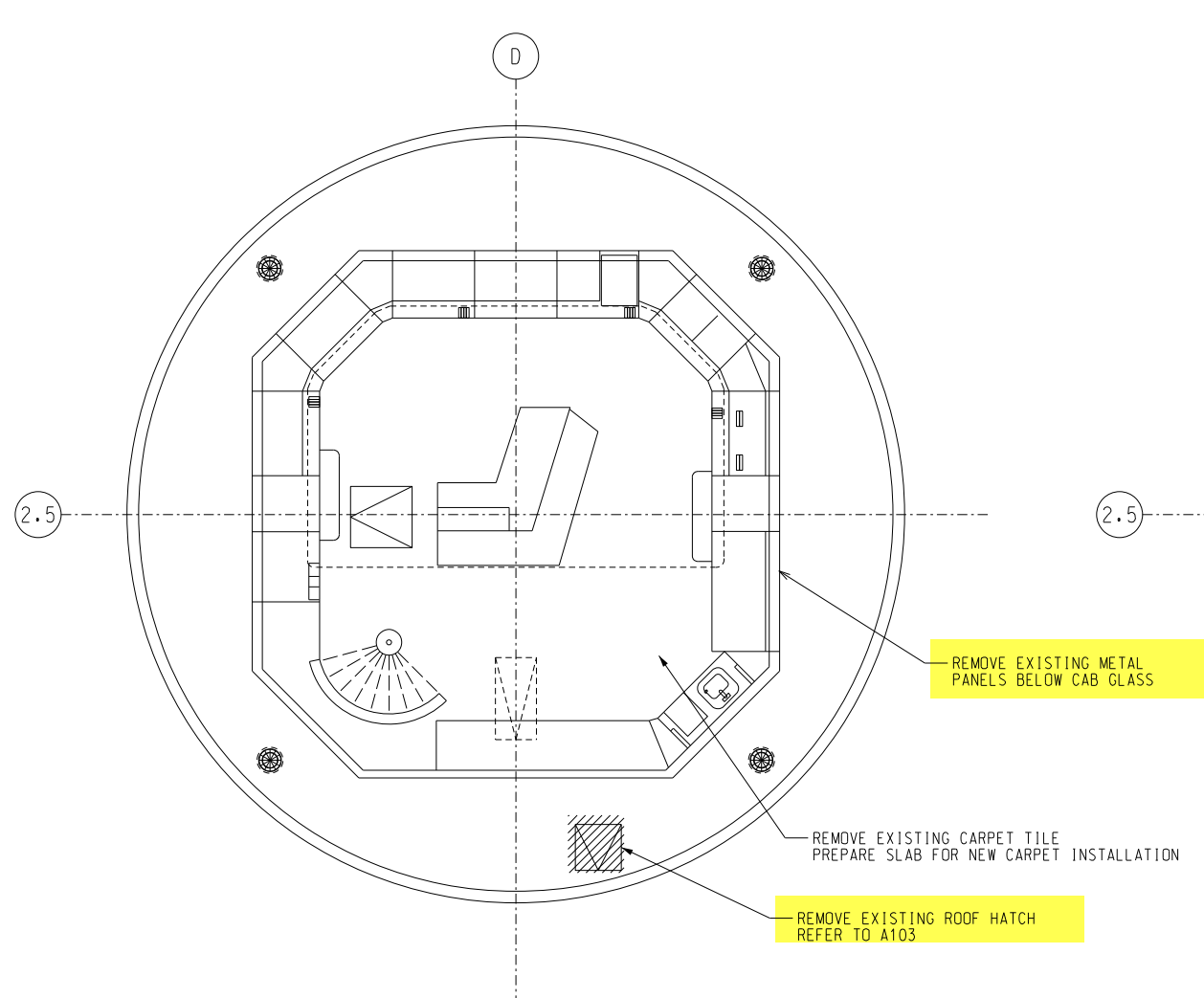
SUBMITTER'S TITLE - CIVIL ENGINEER  
 APPROVER'S TITLE - MANAGER  
 DATE JAN 31, 2020 JCN 1508912  
 DRAWING NO. FLL-D-ATCT-D102 REV



1 CAB DEMOLITION PLAN  
 D103 SCALE: 1/4" = 1' - 0"

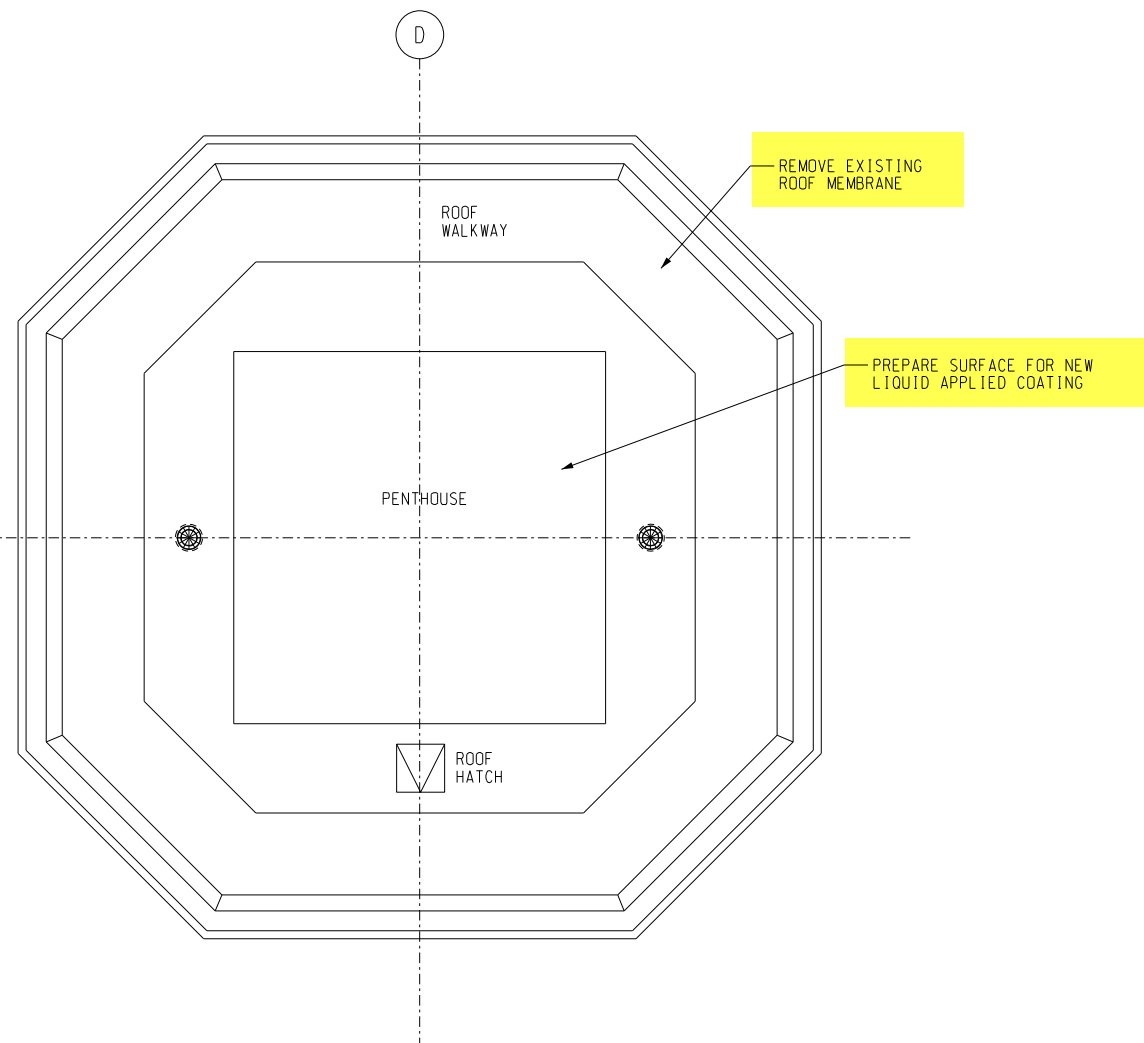

2 ROOF DEMOLITION PLAN  
 D103 SCALE: 1/4" = 1' - 0"

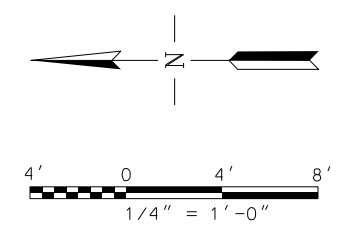

SCALES SHOWN FOR 22" X 34" SHEET. ADJUST SCALES FOR OTHER SIZES. PAGE OF

REV	APPROVED DATE	DESCRIPTION	JCN	REDLINE DATE	APVD

DEPARTMENT OF TRANSPORTATION  
 FEDERAL AVIATION ADMINISTRATION

FORT LAUDERDALE AIRPORT TRAFFIC CONTROL TOWER  
 MAJOR IMPROVEMENTS  
 ARCHITECTURAL  
 CAB FLOOR AND ROOF PLANS DEMOLITION

FT LAUDERDALE (INTERNATIONAL) FL

REVIEWED BY	SUBMITTED BY	APPROVED BY
DESIGNED	GMR	ISSUED BY
DRAWN	GMR	ATLANTA TERMINAL ENGINEERING CENTER
CHECKED	MDS	

DATE JAN 31, 2020 JCN 1508912  
 DRAWING NO FLL-D-ATCT-D103 REV

STATE OF GEORGIA  
 NEIL ESSER  
 REGISTERED ARCHITECT  
 6/1/2020

WileyWilson  
 5901 Peachtree Dunwoody Rd.  
 Bldg. C, Ste 515  
 Atlanta, Georgia 30328-6055  
 678.320.1888  
 wileywilson.com  
 WW JOB NUMBER: 219075.00

What area does this service? Will temp. cooling be required? Hours?

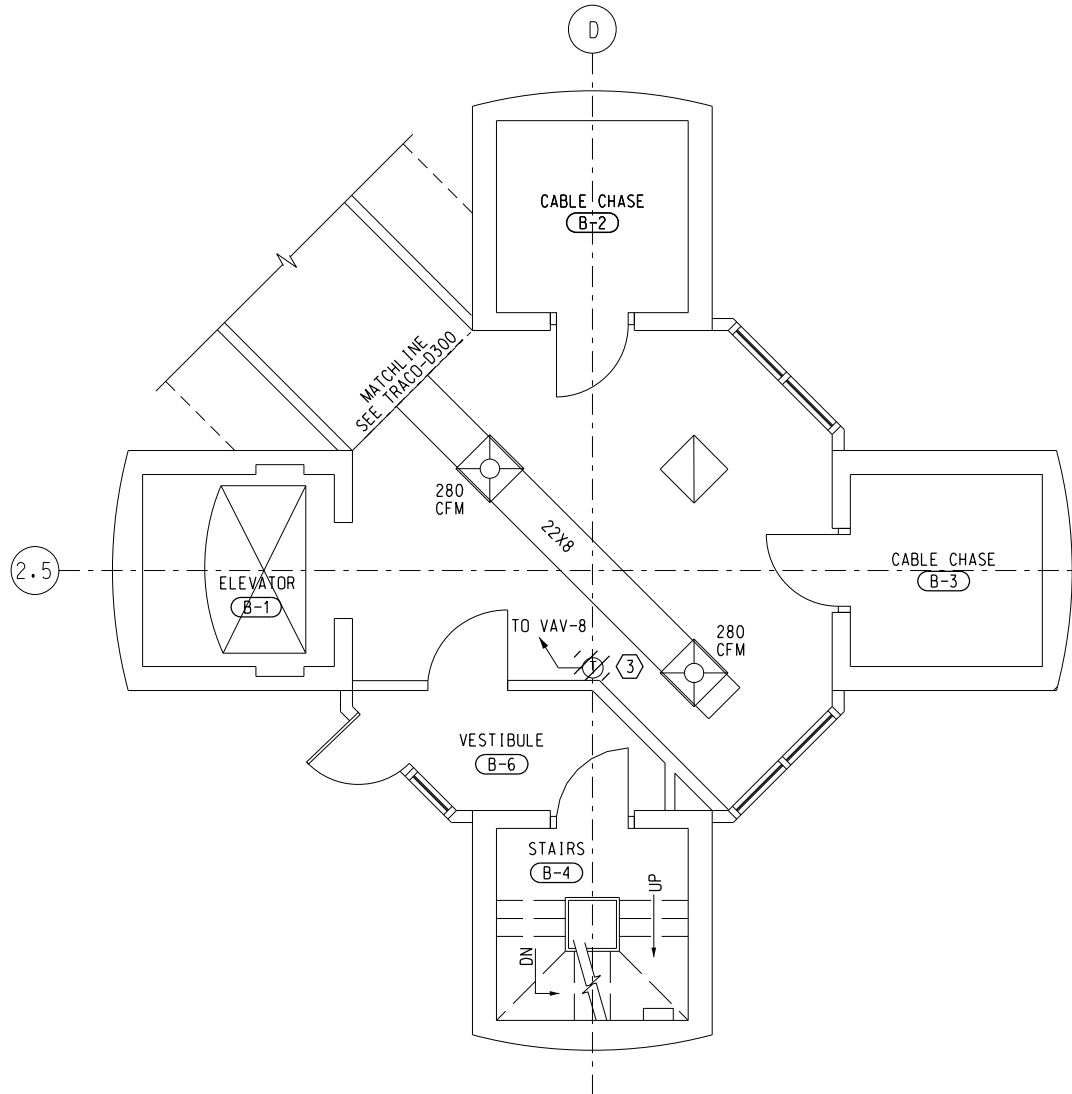

1 GROUND LEVEL PLAN - DEMOLITION  
D300 SCALE: 1/4" = 1'-0"

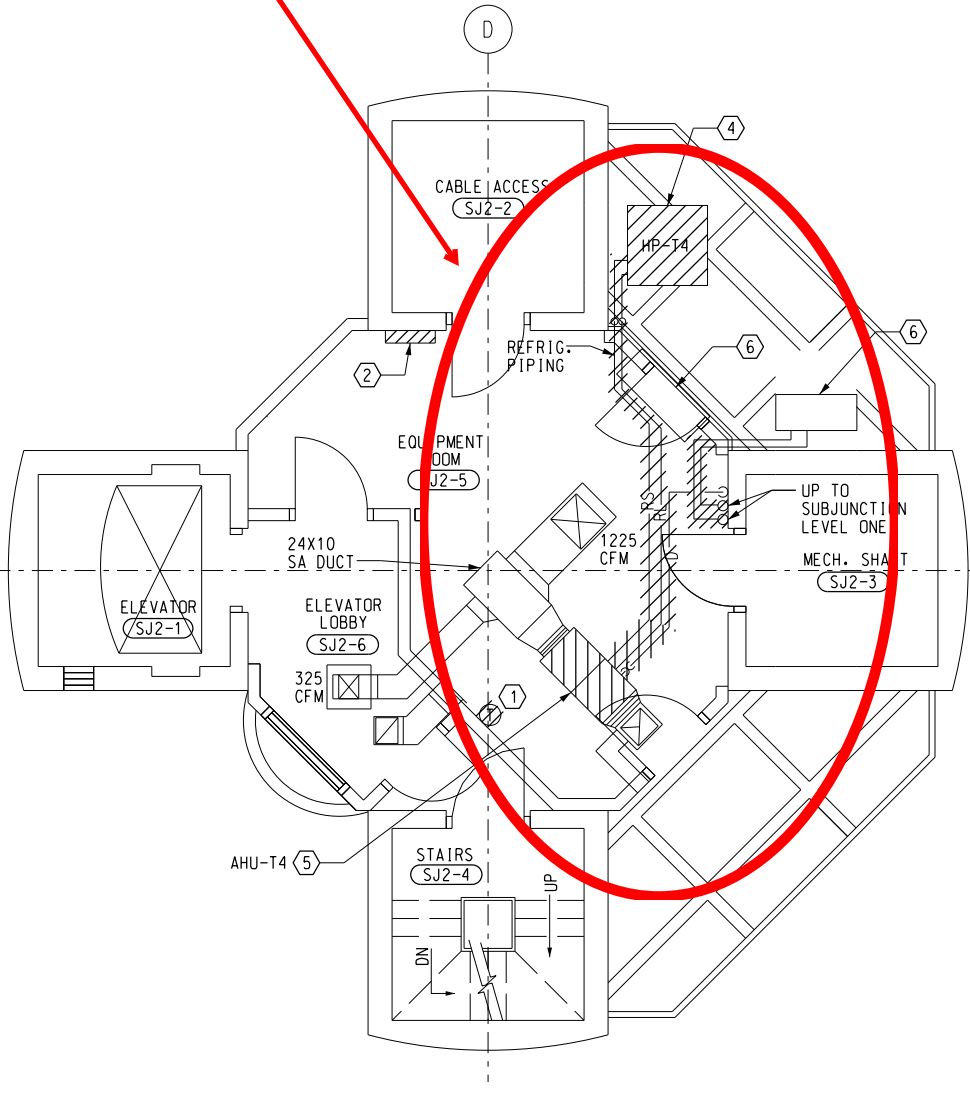

2 SUBJUNCTION LEVEL 2 PLAN - DEMOLITION  
D300 SCALE: 1/4" = 1'-0"

DEMOLITION NOTES

- ① REMOVE EXISTING ROOM SENSOR AND ASSOCIATED CONTROLS.
- ② REMOVE EXISTING DDC CONTROL PANEL FOR AHU-T4.
- ③ REMOVE THERMOSTAT ASSOCIATED WITH VAV BOX.
- ④ REMOVE CONDENSING UNIT HP-T4.
- ⑤ REMOVE AHU-T4 AND ASSOCIATED LINE SET.
- ⑥ EXISTING MINI-SPLIT UNIT TO REMAIN.

GENERAL

- A. EXISTING WORK SHOWN LIGHT DASHED OR LIGHT SOLID LINE WITHOUT HATCHING SHALL REMAIN.
- B. CONTRACTOR SHALL COMPLETELY REMOVE THE EXISTING HVAC CONTROL SYSTEM INCLUDING OPERATOR WORKSTATION, CONTROL PANELS, CONTROL WIRING, THERMOSTATS, AND ALL ASSOCIATED CONTROL COMPONENTS.
- C. CONTRACTOR SHALL REVIEW THE EXISTING CONTROL DRAWINGS AND ACTUAL CONTROL INSTALLATION PRIOR TO PERFORMING ANY WORK AND SHALL MINIMIZE DOWNTIME OF THE HVAC SYSTEM.
- D. SEE DRAWING ATCT-M000 FOR HVAC LEGEND, GENERAL NOTES AND SPECIAL NOTES.
- E. OWNER SHALL HAVE FIRST RIGHT TO ALL EQUIPMENT THAT IS REMOVED.

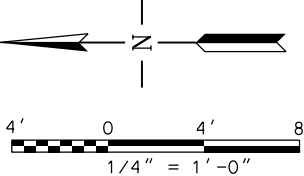

SCALES SHOWN FOR 22" X 34" SHEET. ADJUST SCALES FOR OTHER SIZES.		PAGE	OF
DEPARTMENT OF TRANSPORTATION FEDERAL AVIATION ADMINISTRATION			
FORT LAUDERDALE AIRPORT TRAFFIC CONTROL TOWER MAJOR IMPROVEMENTS MECHANICAL GROUND LEVEL AND SUBJUNCTION LEVEL 2 - DEMOLITION			
FT LAUDERDALE		(INTERNATIONAL)	FL
REVIEWED BY	SUBMITTED BY	APPROVED BY	
SUBMITTER'S TITLE - CIVIL ENGINEER		APPROVER'S TITLE - MANAGER	
DESIGNED	MDS	ISSUED BY	DATE JAN 31, 2020 JCN 1508912
DRAWN	CRK	ATLANTA TERMINAL ENGINEERING CENTER	DRAWING NO
CHECKED	MDS		FLL-D-ATCT-D300
WW JOB NUMBER: 219075.00			

DEMOLITION NOTES

- ① FIELD LOCATE AND REMOVE EXISTING MINI-SPLIT (INDOOR AND OUTDOOR UNITS), LINESET AND ASSOCIATED CONTROLS. AFTER NEW SPLIT SYSTEMS HAVE BEEN INSTALLED.
- ② REMOVE EXISTING OA DUCT.
- ③ REMOVE THERMOSTAT AND ASSOCIATED CONTROLS.
- ④ REMOVE AHU-T1 AND ASSOCIATED LINESET.
- ⑤ REMOVE EXISTING DDC CONTROL PANEL FOR UNITS AHU-T2, T3.
- ⑥ REMOVE EXISTING DDC CONTROLLER FOR AHU-T1.

GENERAL

- A. AIR FLOW SHOWN ON EXISTING SUPPLY AIR OUTLETS ARE FROM AS-BUILT DRAWINGS. CONTRACTOR SHALL PERFORM AIR FLOW TEST AND RECORD THE ACTUAL AIR FLOW ON EXISTING AIR OUTLETS IN BASE BUILDING AND TOWER PRIOR TO BEGINNING ANY HVAC DEMOLITION WORK. RESULTS SHALL BE RETAINED AND USED TO RESTORE THE SYSTEM AT THE COMPLETION OF THE MECHANICAL WORK. THE ACTUAL AIR FLOW SHALL BE SUBMITTED TO THE FAA CONTRACTING OFFICER REPRESENTATIVE FOR REVIEW. AFTER CONSTRUCTION, REBALANCE ALL EXISTING AND NEW AIR DEVICES TO AIR FLOW INDICATED.
- B. EXISTING WORK SHOWN LIGHT DASHED OR LIGHT SOLID LINE WITHOUT HATCHING SHALL REMAIN.
- C. CONTRACTOR SHALL COMPLETELY REMOVE THE EXISTING HVAC CONTROL SYSTEM INCLUDING OPERATOR WORKSTATION, CONTROL PANELS, CONTROL WIRING, THERMOSTATS, AND ALL ASSOCIATED CONTROL COMPONENTS.
- D. CONTRACTOR SHALL REVIEW THE EXISTING CONTROL DRAWINGS AND ACTUAL CONTROL INSTALLATION PRIOR TO PERFORMING ANY WORK AND SHALL MINIMIZE DOWNTIME OF THE HVAC SYSTEM.
- E. SEE DRAWING ATCT-MOOD FOR HVAC LEGEND, GENERAL NOTES AND SPECIAL NOTES.
- F. OWNER SHALL HAVE FIRST RIGHTS TO ALL EQUIPMENT REMOVED.

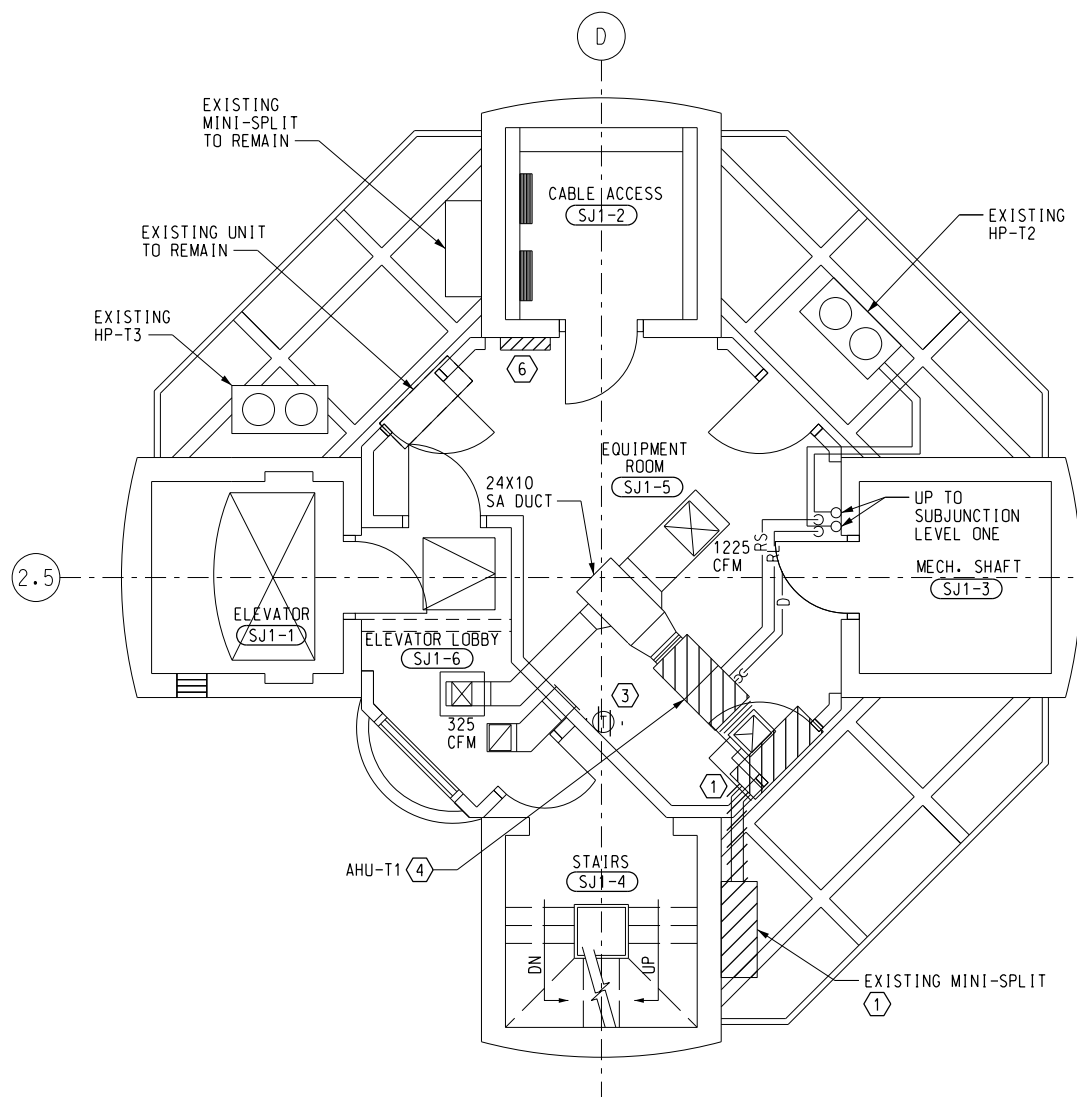

1 SUBJUNCTION LEVEL ONE PLAN - DEMOLITION  
D301 SCALE: 1/4" = 1'-0"

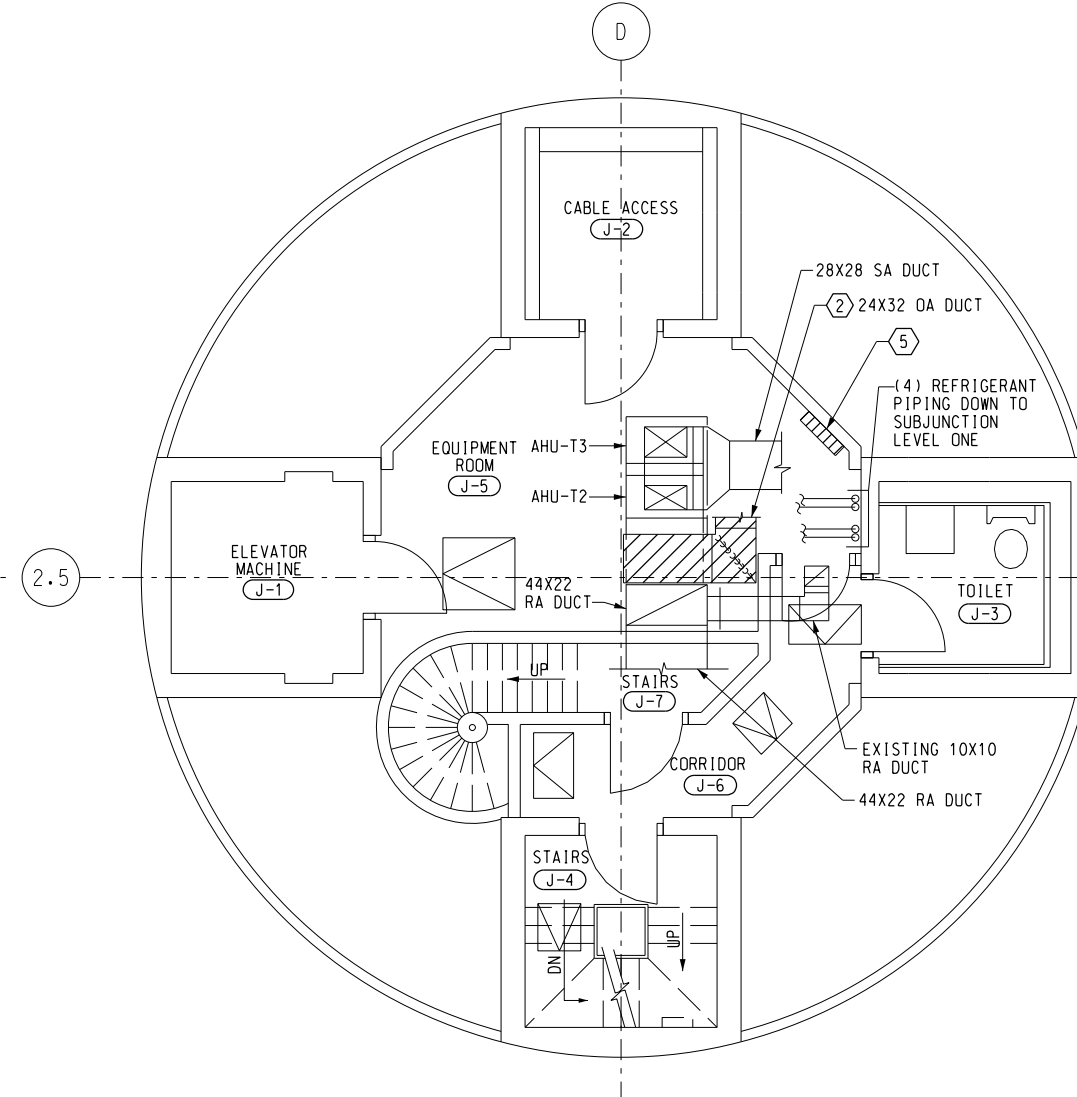

2 JUNCTION LEVEL PLAN - DEMOLITION  
D301 SCALE: 1/4" = 1'-0"

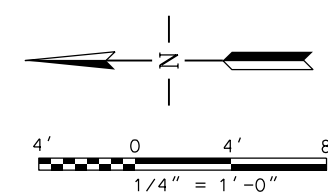

SCALES SHOWN FOR 22" X 34" SHEET. ADJUST SCALES FOR OTHER SIZES.		PAGE	OF
		REV	APPROVED DATE
		DESCRIPTION	JCN
DEPARTMENT OF TRANSPORTATION FEDERAL AVIATION ADMINISTRATION FORT LAUDERDALE AIRPORT TRAFFIC CONTROL TOWER MAJOR IMPROVEMENTS MECHANICAL SUBJUNCTION LEVEL 1 AND JUNCTION LEVEL - DEMOLITION FT LAUDERDALE (INTERNATIONAL) FL		REDATE	APVD
REVIEWED BY	SUBMITTED BY	APPROVED BY	
DESIGNED	MDS	SUBMITTER'S TITLE - CIVIL ENGINEER	
DRAWN	CRK	APPROVER'S TITLE - MANAGER	
CHECKED	MDS	DATE	JCN
		JAN 31, 2020	1508912
		DRAWING NO	REV
		FLL-D-ATCT- D301	

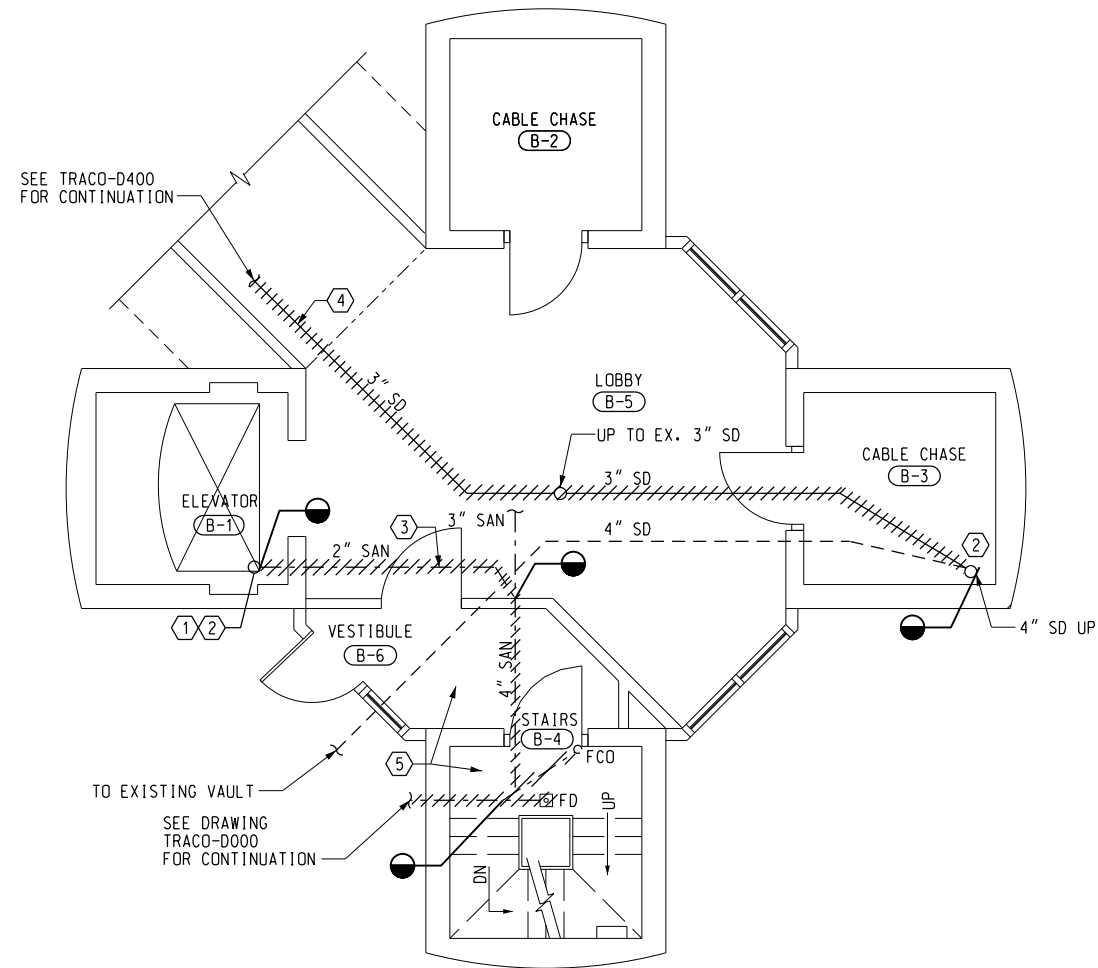

**1** GROUND LEVEL DEMOLITION PLAN  
 D400 SCALE: 1/4" = 1' - 0"



**DEMOLITION NOTES**

- ① EXISTING SUMP PUMP TO REMAIN. REPLACE ALL PIPE SERVED BY SUMP PUMP.
- ② TEE CONNECTING ROOF DRAINS TO STORM DRAIN STACK.
- ③ ALL WORK WITH THIS LINE IS UNDER SLAB. CONTRACTOR SHALL LOCATE LINE UNDER SLAB AND DEMOLISH UP TO 4" SAN MAIN. PATCH CONCRETE OR PROVIDE TEMPORARY COVER SO AS TO MAINTAIN EGRESS AND ELEVATOR ACCESS.
- ④ REMOVE ONLY AS MUCH PIPE AS CAN BE REPAIRED IN ONE NIGHT. TRANSITION FROM 3" SD TO 4" SD MUST ALLOW TOWER TO REMAIN OPERATIONAL.
- ⑤ ALL WORK IN THIS AREA MUST ALLOW EGRESS PATH TO REMAIN IN OPERATION.

**GENERAL NOTES**

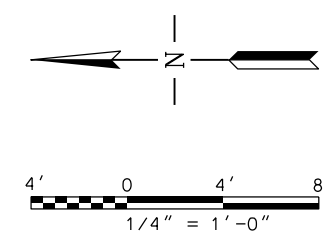
- A. SEE TRACO-P000 FOR GENERAL NOTES AND SYMBOLS. SEE TOWB-G010 AND TOWB-G011 FOR ABBREVIATIONS.

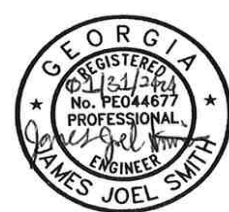

SCALES SHOWN FOR 22" X 34" SHEET. ADJUST SCALES FOR OTHER SIZES.		PAGE	OF												
		<table border="1" style="width: 100%; border-collapse: collapse;"> <thead> <tr> <th>REV</th> <th>APPROVED DATE</th> <th>DESCRIPTION</th> <th>JCN</th> <th>REDLINE DATE</th> <th>APVD</th> </tr> </thead> <tbody> <tr> <td> </td> <td> </td> <td> </td> <td> </td> <td> </td> <td> </td> </tr> </tbody> </table>	REV	APPROVED DATE	DESCRIPTION	JCN	REDLINE DATE	APVD							
REV	APPROVED DATE	DESCRIPTION	JCN	REDLINE DATE	APVD										
DEPARTMENT OF TRANSPORTATION <b>FEDERAL AVIATION ADMINISTRATION</b>															
<b>FORT LAUDERDALE AIRPORT TRAFFIC CONTROL TOWER          MAJOR IMPROVEMENTS          PLUMBING          GROUND LEVEL PLAN - DEMOLITION</b>															
FT LAUDERDALE		(INTERNATIONAL)													
REVIEWED BY	SUBMITTED BY	APPROVED BY													
SUBMITTER'S TITLE - CIVIL ENGINEER		APPROVER'S TITLE - MANAGER													
DESIGNED	JJS	ISSUED BY	DATE												
DRAWN	CRK	ATLANTA TERMINAL ENGINEERING CENTER	JAN 31, 2020												
CHECKED	JJS	DRAWING NO	JCN 1508912												
		<b>FLL-D-ATCT-D400</b>													
 <b>WileyWilson</b> 5901 Peachtree Dunwoody Rd. Bldg. C, Ste 515 Atlanta, Georgia 30328-6055 678.320.1888 wileywilson.com WW JOB NUMBER: 219075.00															

**GENERAL NOTES**

- A. EXISTING WORK SHOWN LIGHT SOLID LINE WITHOUT HATCHING SHALL REMAIN.
- B. SEE DRAWING TRACO-E000 AND TRACO-E001 FOR ELECTRICAL LEGEND, GENERAL NOTES AND SPECIAL NOTES.

**DEMOLITION NOTES**

- ① HP-T4 TO BE REPLACED. CIRCUIT WIRING AND CONDUIT SHALL REMAIN FOR CONNECTION TO NEW UNIT. EQUIPMENT SERVED BY PANEL NLPTA.
- ② REMOVE SPLIT- SYSTEM AND ASSOCIATED CONDENSING UNIT SERVED BY PANEL NLPTA. DISCONNECT AND REMOVE ALL CONDUCTORS AND CONDUIT BACK TO PANEL. LABEL CIRCUIT BREAKER AS "SPARE" IN PANEL DIRECTORY.
- ③ EXISTING AHU-T4 TO BE REPLACED. CIRCUIT WIRING AND CONDUIT SHALL REMAIN FOR CONNECTION TO NEW UNIT. EQUIPMENT SERVED BY PANEL NLPTA.
- ④ EXISTING DDC CONTROL PANEL TO BE REPLACED. CIRCUIT WIRING AND CONDUIT SHALL REMAIN FOR CONNECTION TO NEW PANEL.

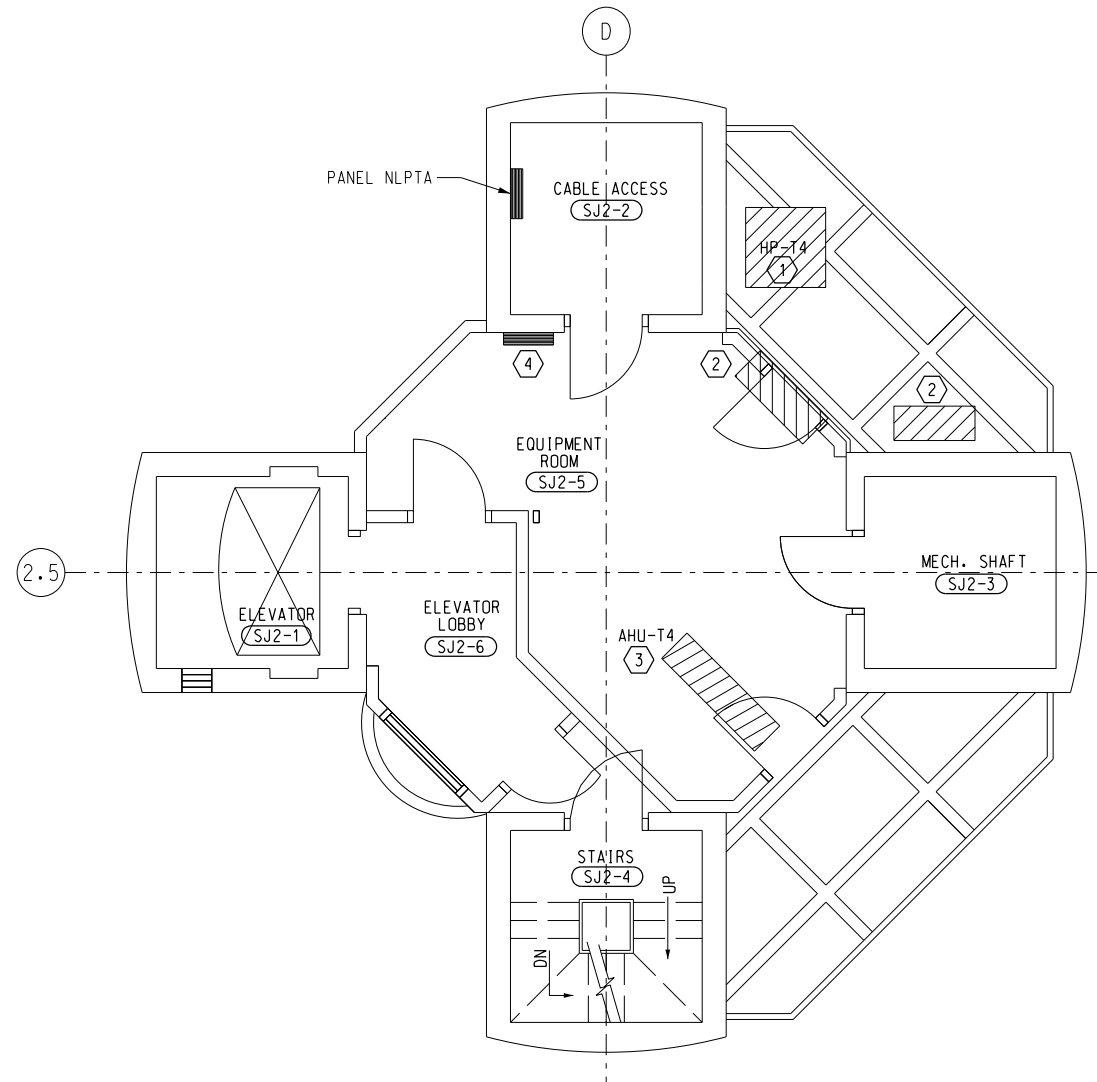

**1** SUBJUNCTION LEVEL TWO PLAN - DEMOLITION  
 D500 SCALE: 1/4" = 1'-0"

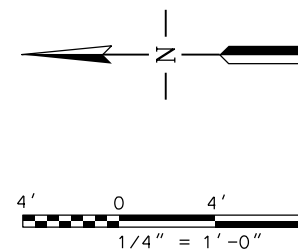

SCALES SHOWN FOR 22" X 34" SHEET. ADJUST SCALES FOR OTHER SIZES.				PAGE	OF
				REV	APVD
APPROVED DATE	DESCRIPTION	JCN	REDLINE DATE	APVD	DATE
DEPARTMENT OF TRANSPORTATION FEDERAL AVIATION ADMINISTRATION  FORT LAUDERDALE AIRPORT TRAFFIC CONTROL TOWER MAJOR IMPROVEMENTS ELECTRICAL GROUND LEVEL AND SUBJUNCTION LEVEL 2 - DEMOLITION FT LAUDERDALE (INTERNATIONAL) FL					
REVIEWED BY	SUBMITTED BY	APPROVED BY			
DESIGNED	MDS	SUBMITTER'S TITLE - CIVIL ENGINEER		APPROVER'S TITLE - MANAGER	
DRAWN	CRK	ISSUED BY		DATE	JCN
CHECKED	MDS	ATLANTA TERMINAL ENGINEERING CENTER		JAN 31, 2020	1508912
				DRAWING NO	REV
				FLL-D-ATCT-D500	
WILEY WILSON 5901 Peachtree Dunwoody Rd. Bldg. C, Ste 515 Atlanta, Georgia 30328-6055 678.320.1888 wileywilson.com WW JOB NUMBER: 219075.00					





	DOOR NUMBER		2' X 4' LAY-IN ACOUSTICAL CEILING
	GYPSUM BOARD PARTITION		2' X 2' LAY-IN ACOUSTICAL CEILING
	PRECAST CONCRETE		SUSPENDED GYPSUM BOARD CEILING
	WINDOW NUMBER		SUPPLY DIFFUSER
	LOUVER NUMBER		RETURN GRILLE
	TYPICAL PARTITION TYPE		EXHAUST GRILLE
	CEILING HEIGHT DESIGNATION		2' X 4' RECESSED FLUORESCENT LIGHTING FIXTURE
	FLOOR HATCH		2' X 2' RECESSED FLUORESCENT LIGHTING FIXTURE
	STEEL LADDER		4' FLUORESCENT LIGHTING FIXTURE, SURFACE MOUNTED
	SUMP		2' FLUORESCENT LIGHTING FIXTURE, SURFACE MOUNTED
	FLOOR MOUNTED SERVICE SINK		4' FLUORESCENT STRIP FIXTURE
	WALL MOUNTED SERVICE SINK		RECESSED FLUORESCENT/INCANDESCENT LIGHTING FIXTURE
	LAVATORY IN COUNTERTOP		RECESSED FLUORESCENT, WALL WASHER LIGHTING FIXTURE
	LAVATORY WALL MOUNTED		WALL-MOUNTED LIGHT FIXTURE
	URINAL		EXIT SIGN
	WATER CLOSET FLOOR MOUNTED		BLACKENED DOT INDICATES FIXTURE WITH EMERGENCY BATTERY PACK
	WATER CLOSET WALL MOUNTED		LOBBY ROOM NUMBER TAG
	ELECTRIC WATER COOLER WALL RECESSED		
	ELECTRIC WATER COOLER WALL HUNG (HANDICAP)		
	LOCKERS		
	HANDICAP DOOR OPERATOR		

SCALES SHOWN FOR 22" X 34" SHEET. ADJUST SCALES FOR OTHER SIZES. PAGE OF

REV	APPROVED DATE	DESCRIPTION	JCN	REDLINE DATE	APVD

STATE OF GEORGIA  
NEIL ESSER  
REGISTERED ARCHITECT  
01/31/2020

**WileyWilson**  
5901 Peachtree Dunwoody Rd.  
Bldg. C, Ste 515  
Atlanta, Georgia 30328-6055  
678.320.1888  
wileywilson.com  
WW JOB NUMBER: 219075.00

DEPARTMENT OF TRANSPORTATION  
FEDERAL AVIATION ADMINISTRATION

FORT LAUDERDALE AIRPORT TRAFFIC CONTROL TOWER  
MAJOR IMPROVEMENTS  
ARCHITECTURAL  
LEGEND, SYMBOLS AND GENERAL NOTES

FT LAUDERDALE (INTERNATIONAL) FL

REVIEWED BY	SUBMITTED BY	APPROVED BY
DESIGNED	SUBMITTER'S TITLE - CIVIL ENGINEER	APPROVER'S TITLE - MANAGER
DRAWN	ISSUED BY	DATE JAN 31, 2020 JCN 1508912
CHECKED	ATLANTA TERMINAL ENGINEERING CENTER	DRAWING NO FLL-D-ATCT-A000 REV

NOTES

- AFTER PLUMBING WORK HAS BEEN COMPLETED, REPAIR CONCRETE SLAB TO A SMOOTH FINISH.

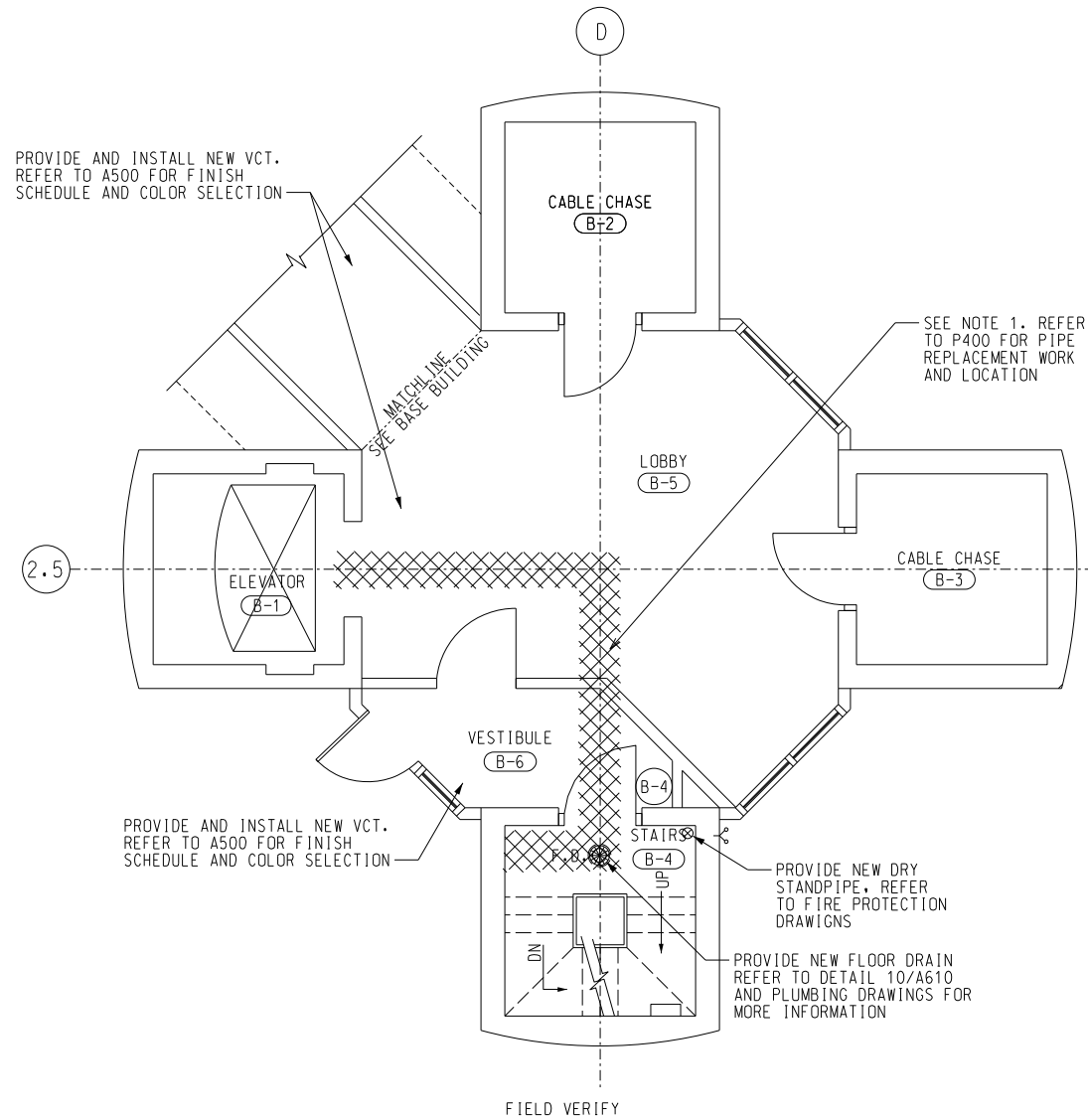

1 GROUND LEVEL FLOOR PLAN  
A100 SCALE: 1/4" = 1' - 0"

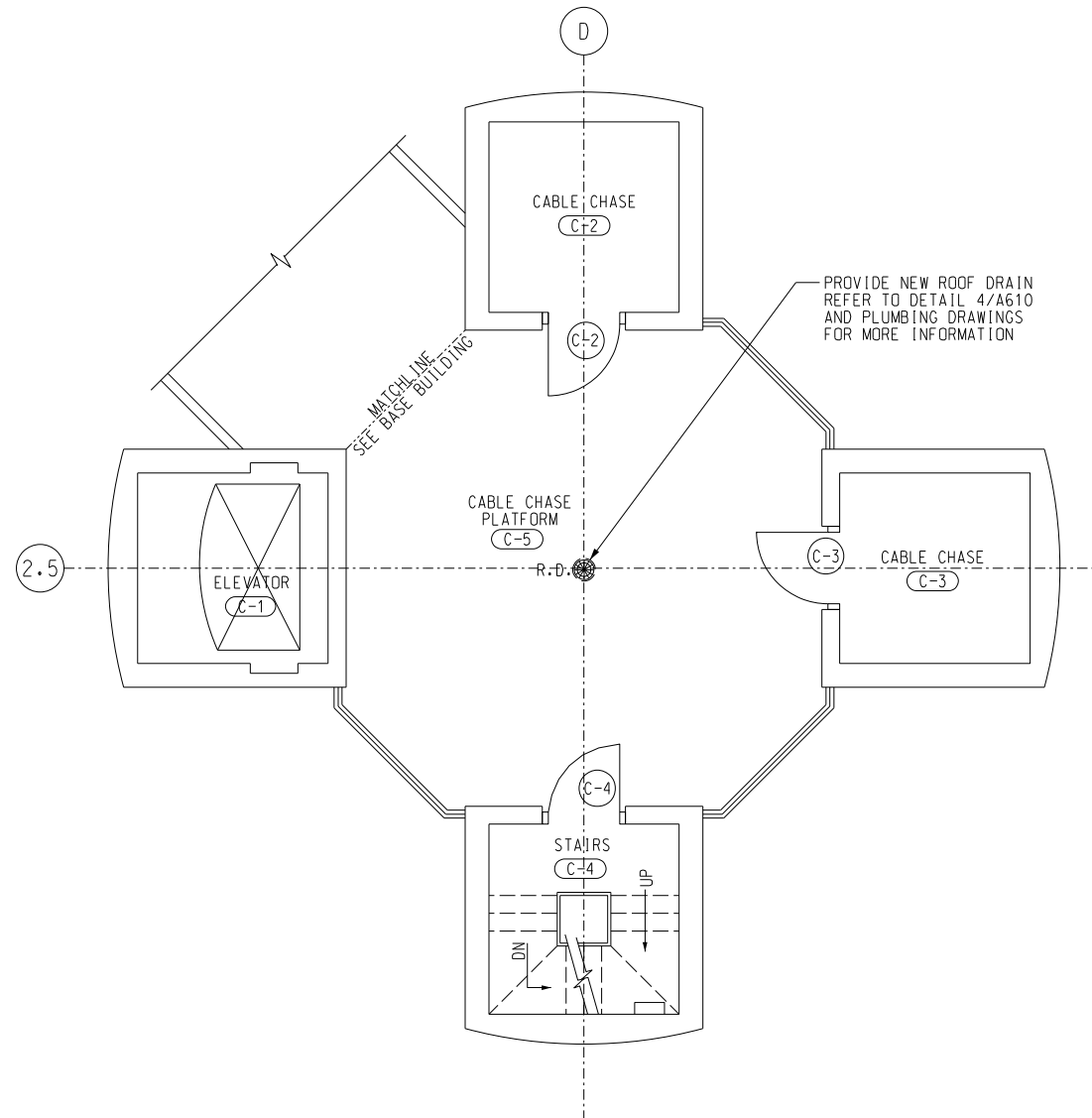

2 SECOND LEVEL FLOOR PLAN  
A100 SCALE: 1/4" = 1' - 0"

NO WORK TO BE DONE IN THIS LEVEL

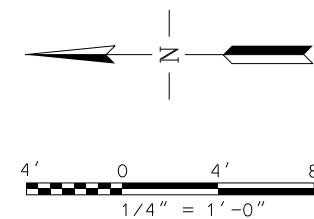

SCALES SHOWN FOR 22" X 34" SHEET. ADJUST SCALES FOR OTHER SIZES. PAGE OF

REV	APPROVED DATE	DESCRIPTION	JCN	REDLINE DATE	APVD

DEPARTMENT OF TRANSPORTATION  
FEDERAL AVIATION ADMINISTRATION

FORT LAUDERDALE AIRPORT TRAFFIC CONTROL TOWER  
MAJOR IMPROVEMENTS  
ARCHITECTURAL  
GROUND AND SECOND FLOOR PLAN

FT LAUDERDALE (INTERNATIONAL) FL

REVIEWED BY	SUBMITTED BY	APPROVED BY
DESIGNED	GMR	ISSUED BY
DRAWN	GMR	ATLANTA TERMINAL ENGINEERING CENTER
CHECKED	NXE	

DATE JAN 31, 2020 JCN 1508912  
DRAWING NO FLL-D-ATCT-A100 REV

STATE OF GEORGIA  
NEIL ESSER  
REGISTERED ARCHITECT  
01/31/2020

WileyWilson  
5901 Peachtree Dunwoody Rd.  
Bldg. C, Ste 515  
Atlanta, Georgia 30328-6055  
678.320.1888  
wileywilson.com  
WW JOB NUMBER: 219075.00

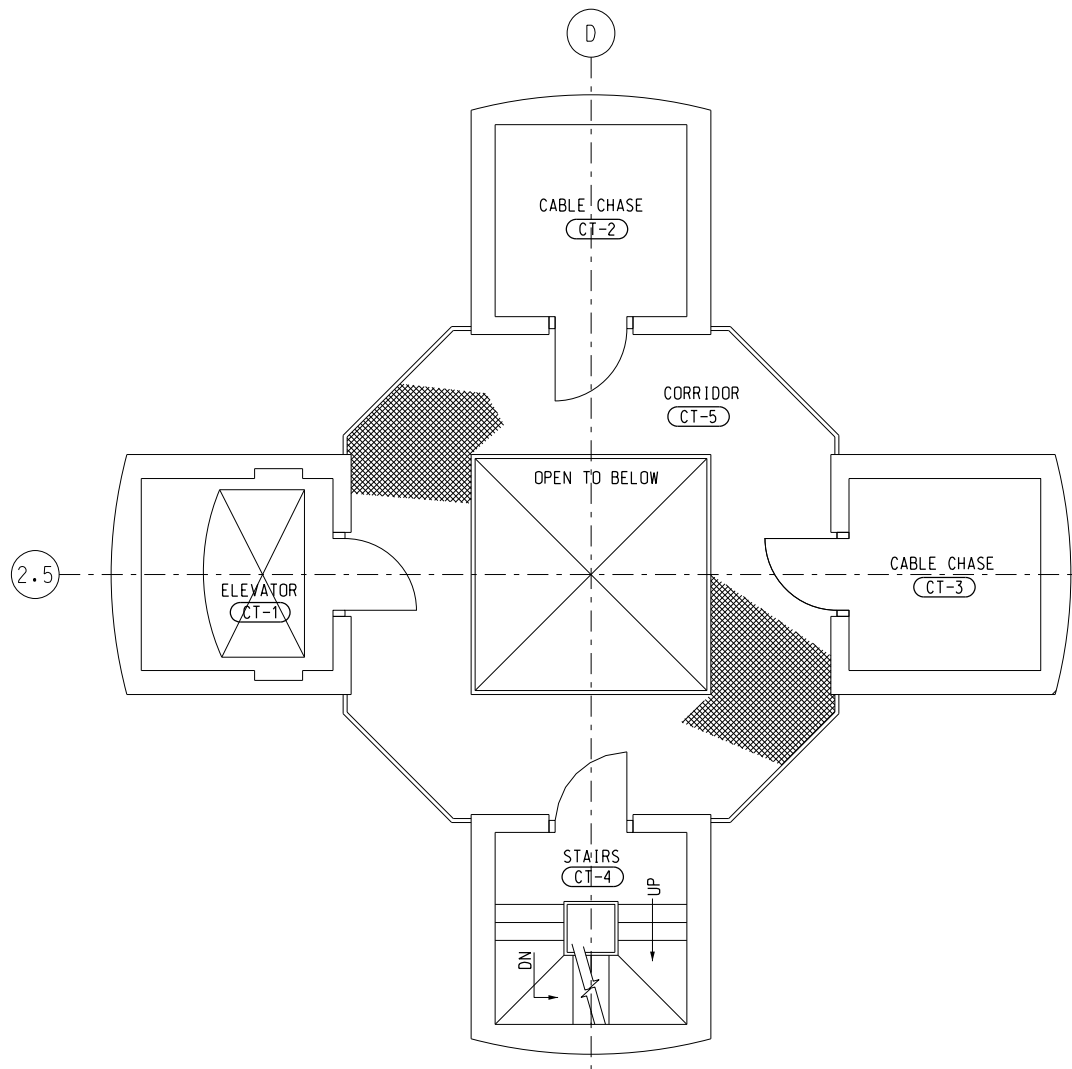

1 TYP. CABLE ACCESS FLOOR PLAN  
A101 SCALE: 1/4" = 1' - 0"

NO WORK TO BE DONE IN THESE LEVELS

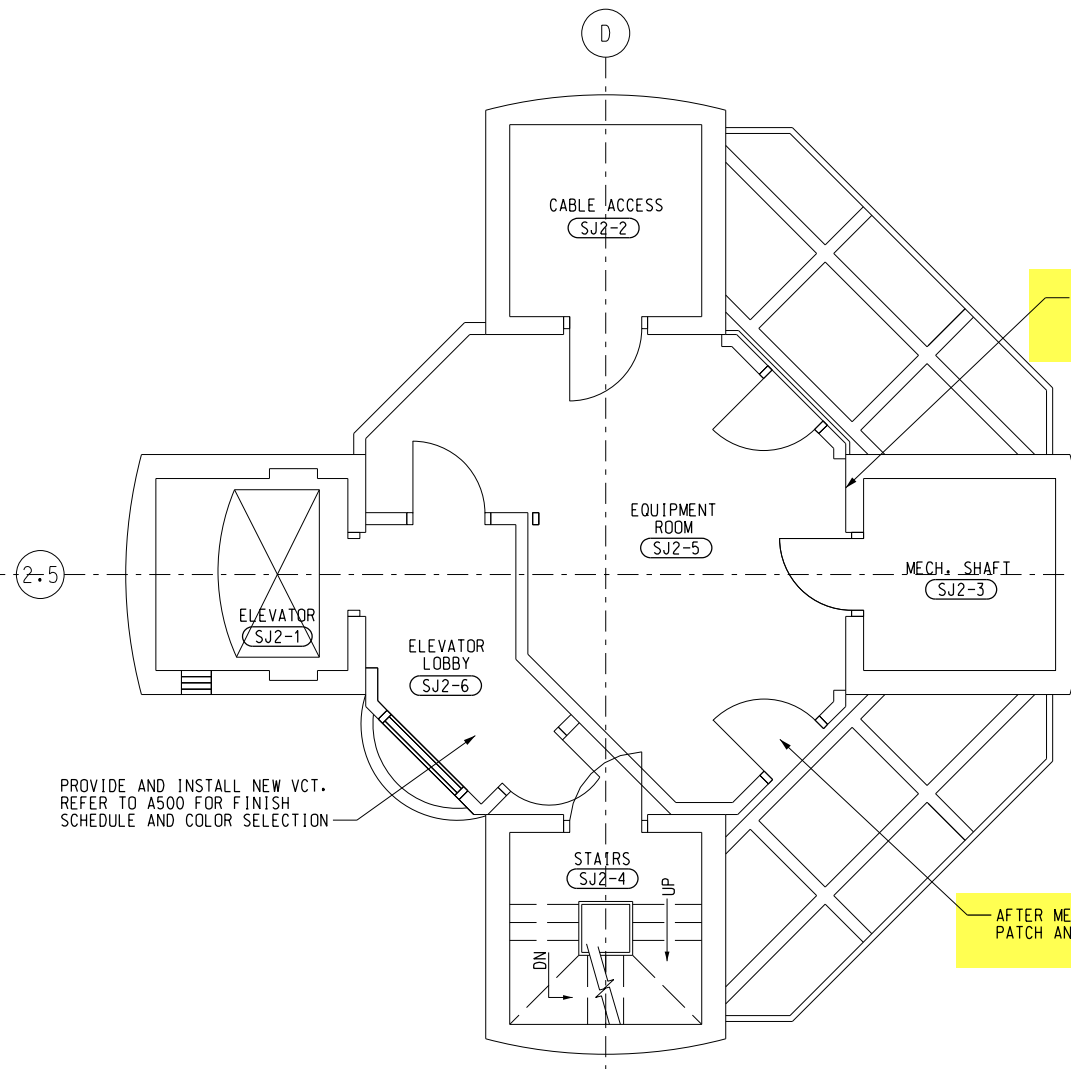

2 SUBJUNCTION LEVEL 2 FLOOR PLAN  
A101 SCALE: 1/4" = 1' - 0"

PROVIDE AND INSTALL NEW VCT. REFER TO A500 FOR FINISH SCHEDULE AND COLOR SELECTION

REPAIR AND PATCH WALL AS NECESSARY AFTER MECHANICAL AND ELECTRICAL WORK IS COMPLETED

To what extent is to be painted?

AFTER MECHANICAL DEMOLITION PATCH AND PAINT WALL

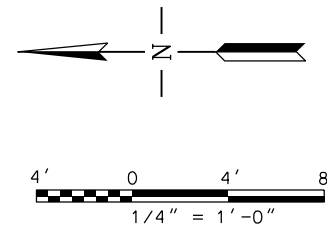

SCALES SHOWN FOR 22" X 34" SHEET. ADJUST SCALES FOR OTHER SIZES. PAGE OF

REV	APPROVED DATE	DESCRIPTION	JCN	REDLINE DATE	APVD

DEPARTMENT OF TRANSPORTATION  
FEDERAL AVIATION ADMINISTRATION

FORT LAUDERDALE AIRPORT TRAFFIC CONTROL TOWER  
MAJOR IMPROVEMENTS  
ARCHITECTURAL  
CABLE ACCESS PLAN AND SUBJUNCTION LEVEL 2  
FT LAUDERDALE (INTERNATIONAL) FL

REVIEWED BY	SUBMITTED BY	APPROVED BY
DESIGNED	GMR	ISSUED BY
DRAWN	GMR	ATLANTA TERMINAL ENGINEERING CENTER
CHECKED	NXE	

DATE JAN 31, 2020 JCN 1508912  
DRAWING NO FLL-D-ATCT-A101 REV

WileyWilson  
5901 Peachtree Dunwoody Rd.  
Bldg. C, Ste 515  
Atlanta, Georgia 30328-6055  
678.320.1888  
wileywilson.com  
WW JOB NUMBER: 219075.00



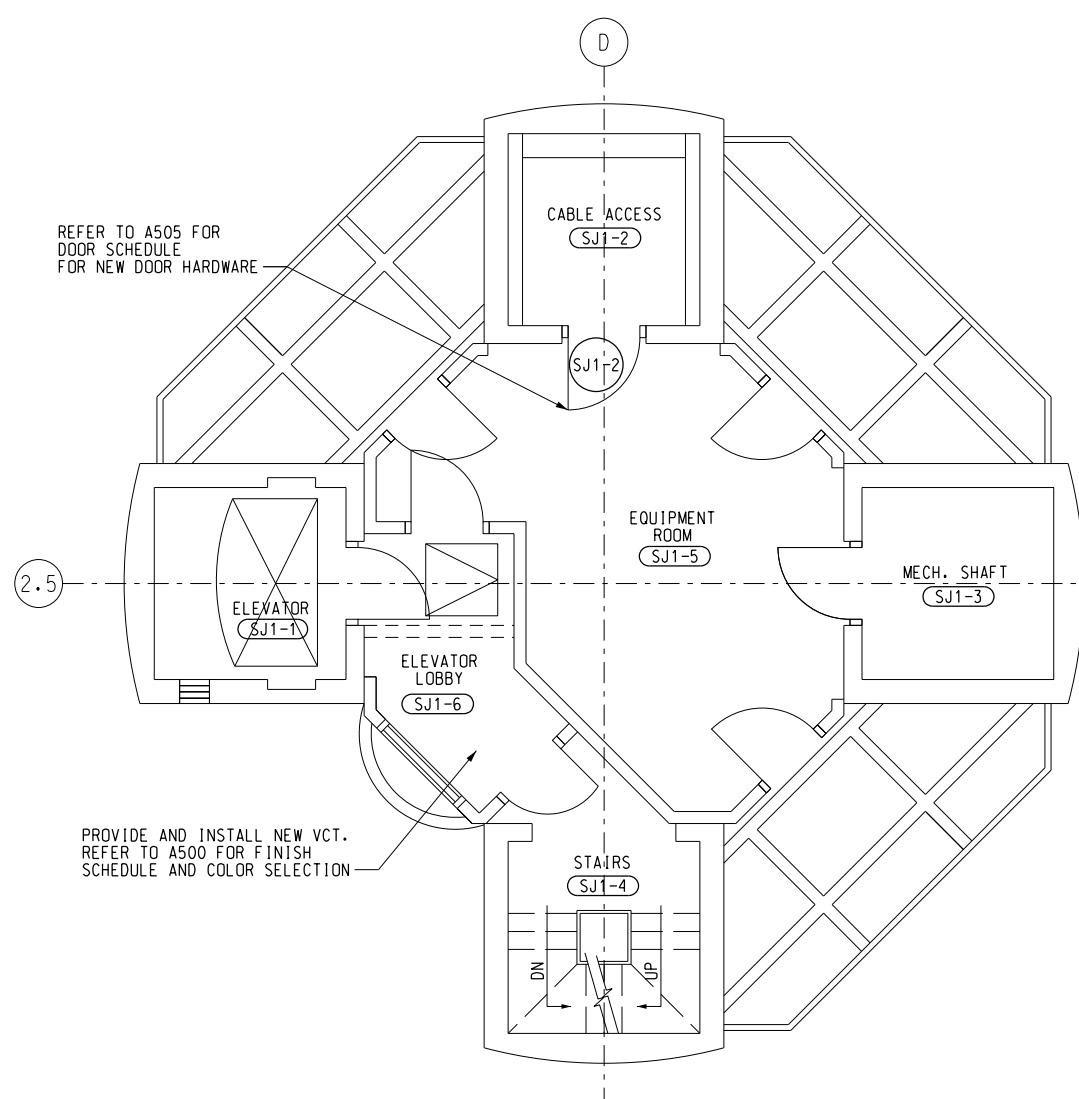

**1** SUBJUNCTION LEVEL 1 FLOOR PLAN  
**A102** SCALE: 1/4" = 1' - 0"  
 SEE A121 FOR WORK ON THE UNDERSIDE OF THIS LEVEL

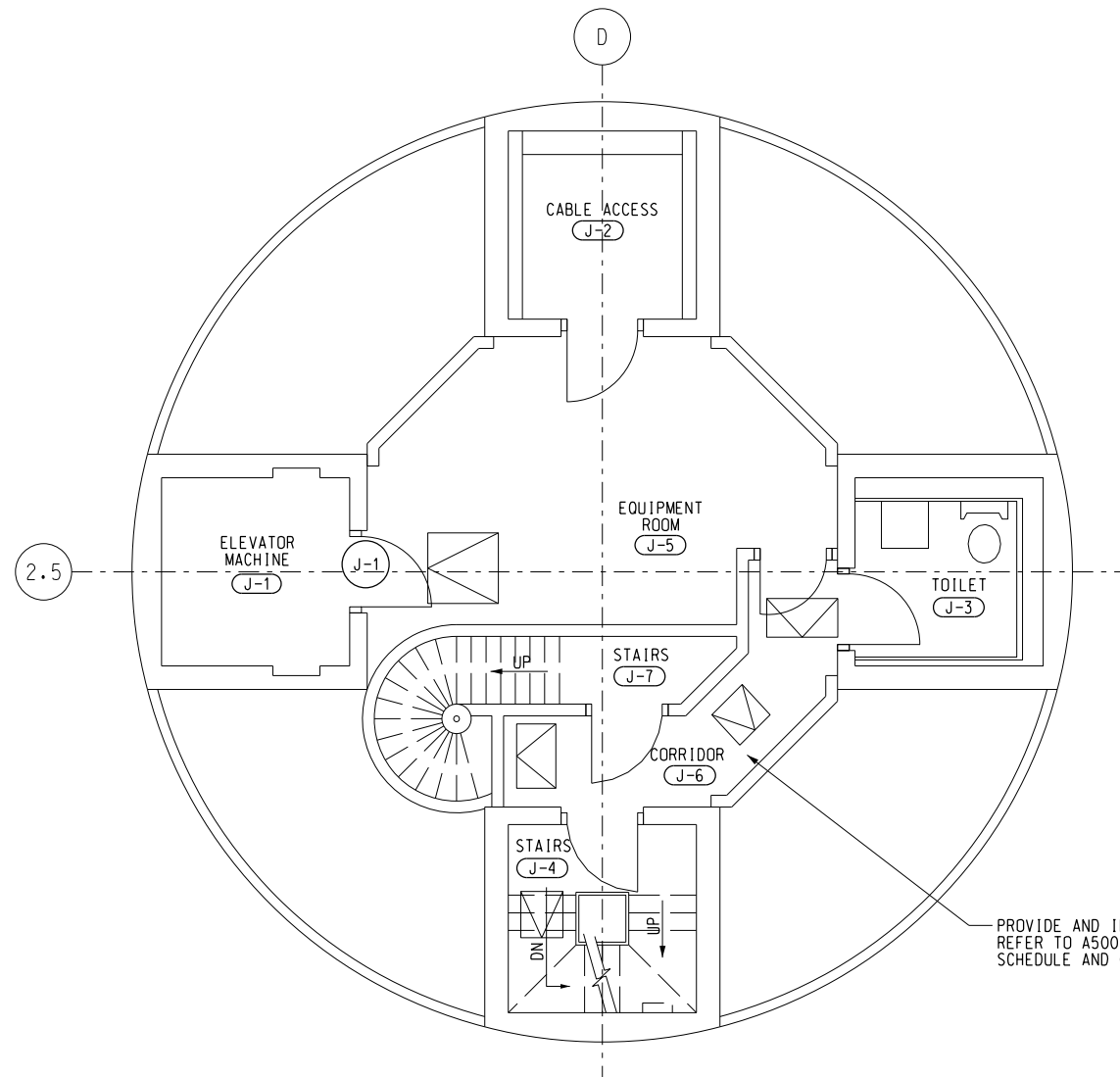

**2** JUNCTION LEVEL FLOOR PLAN  
**A102** SCALE: 1/4" = 1' - 0"

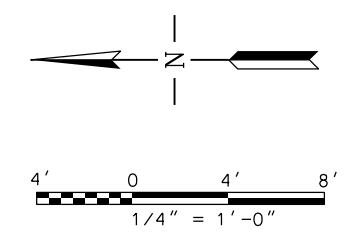

SCALES SHOWN FOR 22" X 34" SHEET. ADJUST SCALES FOR OTHER SIZES. PAGE OF

REV	APPROVED DATE	DESCRIPTION	JCN	REDLINE DATE	APVD

STATE OF GEORGIA  
 NEIL ESSER  
 ARCHITECT  
 REGISTERED ARCHITECT  
 01/31/2020

**Wiley|Wilson**  
 5901 Peachtree Dunwoody Rd.  
 Bldg. C, Ste 515  
 Atlanta, Georgia 30328-6055  
 678.320.1888  
 wileywilson.com  
 WW JOB NUMBER: 219075.00

DEPARTMENT OF TRANSPORTATION  
 FEDERAL AVIATION ADMINISTRATION  
 FORT LAUDERDALE AIRPORT TRAFFIC CONTROL TOWER  
 MAJOR IMPROVEMENTS  
 ARCHITECTURAL  
 SUBJUNCTION LEVEL 1 AND JUNCTION LEVEL  
 FT LAUDERDALE (INTERNATIONAL) FL

REVIEWED BY	SUBMITTED BY	APPROVED BY
DESIGNED	ISSUED BY	APPROVER'S TITLE - MANAGER
DRAWN	ATLANTA TERMINAL ENGINEERING CENTER	DATE JAN 31, 2020 JCN 1508912
CHECKED		DRAWING NO. FLL-D-ATCT- A102 REV

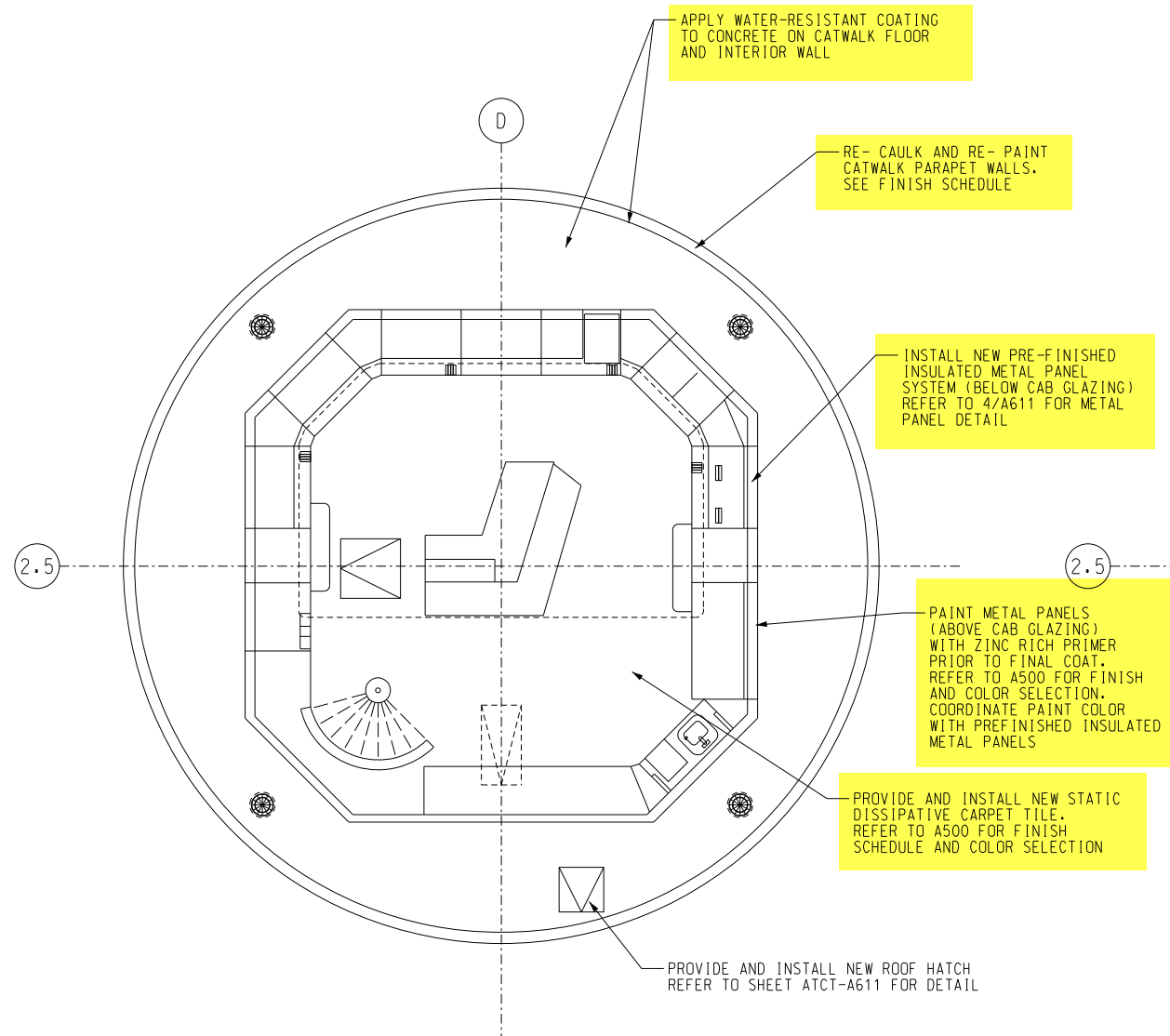

1 CAB FLOOR PLAN  
A103 SCALE: 1/4" = 1' - 0"

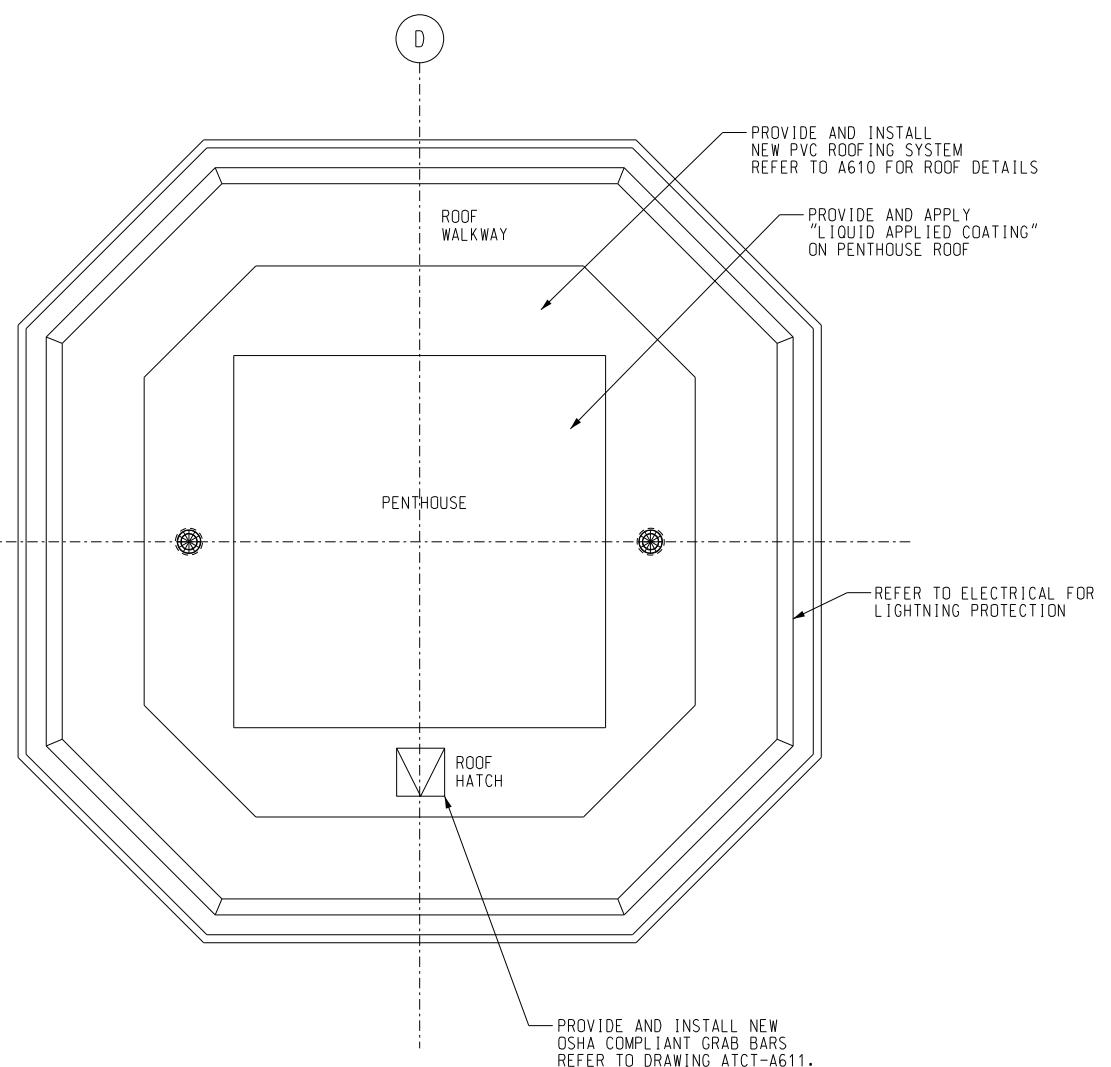

2 CAB ROOF PLAN  
A103 SCALE: 1/4" = 1' - 0"

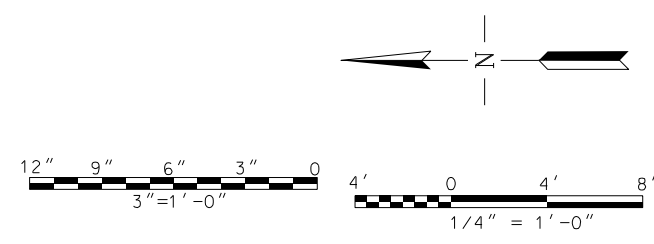

SCALES SHOWN FOR 22" X 34" SHEET. ADJUST SCALES FOR OTHER SIZES. PAGE OF

REV	APPROVED DATE	DESCRIPTION	JCN	REDLINE DATE	APVD

STATE OF GEORGIA  
NEIL ESSER  
REGISTERED ARCHITECT  
01/31/2020

DEPARTMENT OF TRANSPORTATION  
FEDERAL AVIATION ADMINISTRATION

FORT LAUDERDALE AIRPORT TRAFFIC CONTROL TOWER  
MAJOR IMPROVEMENTS  
ARCHITECTURAL  
CAB LEVEL FLOOR AND ROOF PLANS

FT LAUDERDALE (INTERNATIONAL) FL

REVIEWED BY	SUBMITTED BY	APPROVED BY
DESIGNED	GMR	ISSUED BY
DRAWN	GMR	ATLANTA TERMINAL ENGINEERING CENTER
CHECKED	NXE	

5901 Peachtree Dunwoody Rd.  
Bldg. C, Ste 515  
Atlanta, Georgia 30328-6055  
678.320.1888  
wileywilson.com  
WW JOB NUMBER: 219075.00

SUBMITTER'S TITLE - CIVIL ENGINEER  
APPROVER'S TITLE - MANAGER  
DATE JAN 31, 2020 JCN 1508912  
DRAWING NO FLL-D-ATCT- A103 REV

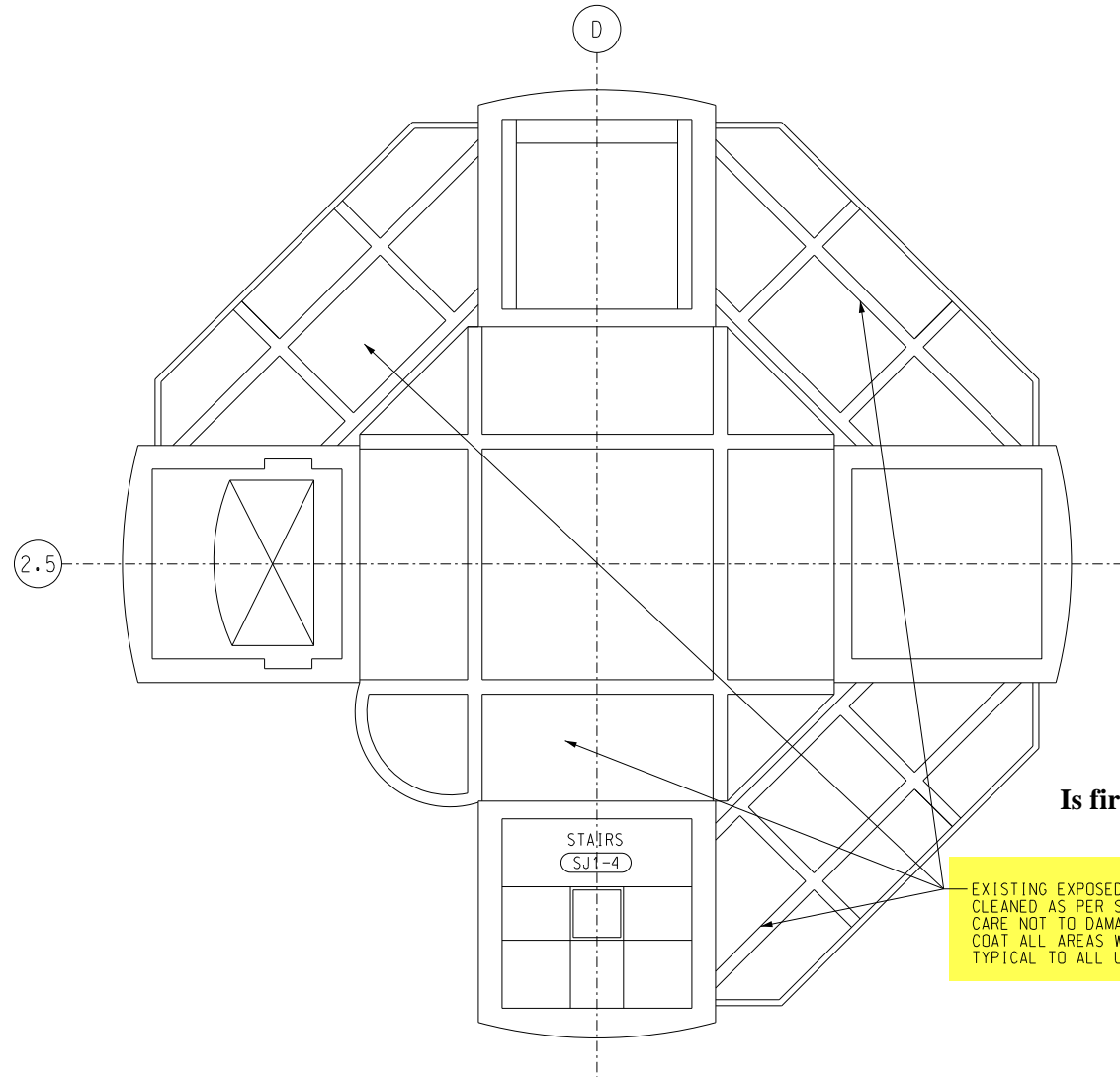

**Is fire proofing currently attached to this area? If yes will it be required to reapply?**

EXISTING EXPOSED STRUCTURAL STEEL AND METAL DECK TO BE HANDTOOL CLEANED AS PER SPEC 05 12 13 SSPC-SP2 ON EXPOSED SIDES, TAKING CARE NOT TO DAMAGE EXISTING STRUCTURAL MEMBERS AND CONNECTIONS. COAT ALL AREAS WITH A ZINC RICH PRIMER PRIOR TO FINAL COAT. TYPICAL TO ALL UNDERSIDE OF SUBJUNCTION LEVEL 1 (7TH LEVEL).

1 CABLE ACCESS 7TH LEVEL - RCP  
A121 SCALE: 1/4" = 1' - 0"

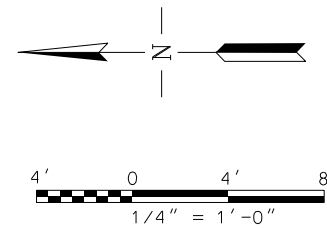

SCALES SHOWN FOR 22" X 34" SHEET. ADJUST SCALES FOR OTHER SIZES.				PAGE	OF
REV	APPROVED DATE	DESCRIPTION	JCN	REDLINE DATE	APVD
DEPARTMENT OF TRANSPORTATION FEDERAL AVIATION ADMINISTRATION					
FORT LAUDERDALE AIRPORT TRAFFIC CONTROL TOWER MAJOR IMPROVEMENTS ARCHITECTURAL CABLE ACCESS 7TH LEVEL - RCP FT LAUDERDALE (INTERNATIONAL) FL					
REVIEWED BY	SUBMITTED BY	APPROVED BY			
DESIGNED	GMR	SUBMITTER'S TITLE - CIVIL ENGINEER		APPROVER'S TITLE - MANAGER	
DRAWN	GMR	ISSUED BY		DATE	JCN
CHECKED	NXE	ATLANTA TERMINAL ENGINEERING CENTER		JAN 31, 2020	1508912
WILEY WILSON				DRAWING NO	
5901 Peachtree Dunwoody Rd. Bldg. C, Ste 515 Atlanta, Georgia 30328-6055 678.320.1888 wileywilson.com				FLL-D-ATCT-A121	
WW JOB NUMBER: 219075.00					

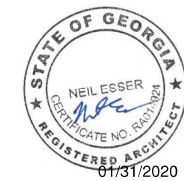

**Wiley|Wilson**  
5901 Peachtree Dunwoody Rd.  
Bldg. C, Ste 515  
Atlanta, Georgia 30328-6055  
678.320.1888  
wileywilson.com

WW JOB NUMBER: 219075.00



ROOM FINISH SCHEDULE										
ROOM NUMBER	ROOM NAME	FLOOR	BASE	WALL				CEILING		REMARKS
				NORTH	EAST	SOUTH	WEST	FINISH	HEIGHT	
FIRST LEVEL (GROUND)										
B-5	LOBBY	VCT-1	RB-1	P-1	P-1	P-1	P-1	-	-	REFER TO DETAIL 2/A500
B-6	VESTIBULE	VCT-1	RB-1	P-1	P-1	P-1	P-1	-	-	REFER TO DETAIL 1/A500
CABLE ACCESS (7TH LEVEL)										
CCT-1	CABLE ACCESS LEVEL	-	-	-	-	-	-	P-2	EXISTING	REFER TO DETAIL 1/A500
SUBJUNCTION LEVEL 2										
SJ2-6	ELEVATOR LOBBY	VCT-1	RB-1	P-1	P-1	P-1	P-1	-	-	REFER TO DETAIL 1/A500
SUBJUNCTION LEVEL 1										
SJ1-6	ELEVATOR LOBBY	VCT-1	RB-1	P-1	P-1	P-1	P-1	-	-	REFER TO DETAIL 1/A500
JUNCTION LEVEL										
J-3	TOILET	-	-	-	-	-	-	-	-	
J-6	CORRIDOR	VCT-1	RB-1	P-1	P-1	P-1	P-1	-	-	REFER TO DETAIL 1/A500
J-7	STAIRS	VCT-1	RB-1	P-1	P-1	P-1	P-1	-	-	REFER TO DETAIL 2/A500
CAB										
CAB	CAB	CPT-2	RB-1	-	-	-	-	-	-	

INTERIOR COLOR SELECTIONS	
CARPET (CPT) CPT-1 FOR THE BASE BUILDING  CPT-2 ELECTROSTATIC DISSIPATIVE TYPE CARPET, 24" X 24" SIZE. JULIE INDUSTRIES. COLOR: GALILEO - CONTEMPO #4070.	PAINT (P) P-1 SHERWIN WILLIAMS 6253 "OLYMPUS WHITE" P-2 SHERWIN WILLIAMS 7006 "EXTRA WHITE" (EXPOSED STRUCTURE ABOVE)
RUBBER BASE (RB) RB-1 4" COVED WALL BASE COLOR EQUAL TO "ROPPE P129 DOLPHIN"	RESILIENT FLOORING (VCT) - VINYL COMPOSITE TILE VCT-1 COLOR EQUAL TO "AZROCK VINYL ENHANCED TILE, AZTERRA AT-104 GREY ROCK."

EXTERIOR COLOR SELECTIONS	
EXTERIOR PAINT (XP) XP-1 SHERWIN WILLIAMS 6005 "FOLKSTONE". SEE NOTE 1. FOR: DOORS, FRAMES AND METAL PANELS. XP-2 GALVANIZED STEEL TO BE PAINTED WITH ZINC RICH PAINT CONFORMING TO ASTM A780. COLOR: SHERWIN WILLIAMS 6005 "FOLKSTONE" SEE NOTE 1.	
EXTERIOR PAINT (XP) MP-1 CENTRIA, COLOR: DARK BRONZE ANODIZED. SEE NOTE 1	

**NOTES:**

- PRIOR TO ORDERING ANY MATERIALS, COORDINATE WITH FAA FOR FINAL COLOR SELECTION AND PROVIDE COLOR SAMPLES, REFLECTING ALL FINISHES NOTED ABOVE, AND ANY CONTRACTOR SUBSTITUTED FINISHES, TO COR FOR APPROVAL.

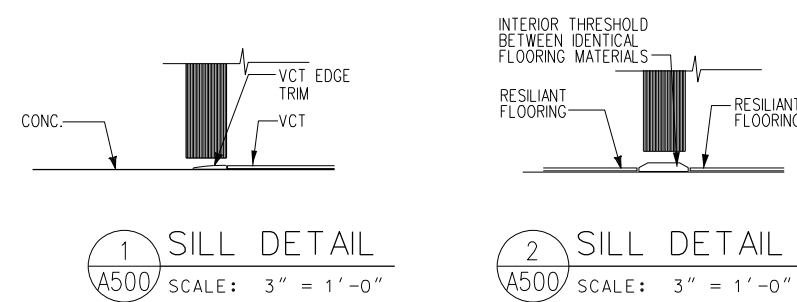

SCALES SHOWN FOR 22" X 34" SHEET. ADJUST SCALES FOR OTHER SIZES. PAGE OF

REV	APPROVED DATE	DESCRIPTION	JCN	REDLINE DATE	APVD
DEPARTMENT OF TRANSPORTATION FEDERAL AVIATION ADMINISTRATION  FORT LAUDERDALE AIRPORT TRAFFIC CONTROL TOWER MAJOR IMPROVEMENTS ARCHITECTURAL FINISH SCHEDULE AND COLOR SELECTIONS  FT LAUDERDALE (INTERNATIONAL) FL					
REVIEWED BY		SUBMITTED BY		APPROVED BY	
		SUBMITTER'S TITLE - CIVIL ENGINEER		APPROVER'S TITLE - MANAGER	
		DESIGNED GMR		ISSUED BY	
		DRAWN GMR		DATE JAN 31, 2020 JCN 1508912	
		CHECKED NXE		DRAWING NO. FLL-D-ATCT-A500	

**WileyWilson**  
5901 Peachtree Dunwoody Rd.  
Bldg. C, Ste 515  
Atlanta, Georgia 30328-6055  
678.320.1888  
wileywilson.com  
WW JOB NUMBER: 219075.00

DOOR SCHEDULE																													
LOCATION			DOOR			SCHEDULE				FRAME SCHEDULE			HARDWARE SCHEDULE						SECURITY DOOR MATRIX						SIGN				
LEVEL/FLOOR	DOOR #	DOOR LOCATION	REMOVE EXIST AND INSTALL NEW DOOR AND FRAME	INSTALL NEW DOOR	NEW HARDWARE ONLY	WIDTH	HEIGHT	THICK.	MATERIAL	FINISH	TYPE	TYPE	MATERIAL	FINISH	PAIR HINGES TOTAL	DOOR CLOSER	WEATHER STRIP	LOCK SET TYPE	EXT. RATED	FIRE RATED									
GROUND	B-4	STAIRS			●	-	-	-	-	-	-	-	-	-	-	●	-	P	-	-	-	-	-	-	-	-	-	-	-
SECOND	C-2	CABLE CHASE	●			3'-0"	7'-0"	1 3/4"	STL	PAINT	(A)	(1)	STL	PAINT	1.5	●	●	D	●	90									
	C-3	CABLE CHASE	●			3'-0"	7'-0"	1 3/4"	STL	PAINT	(A)	(1)	STL	PAINT	1.5	●	●	D	●	90									
	C-4	STAIRS	●			3'-0"	7'-0"	1 3/4"	STL	PAINT	(A)	(1)	STL	PAINT	1.5	●	●	P	●	90									
SUBJUNCTION	SJ1-2	CABLE CHASE			●	-	-	-	-	-	-	-	-	-	-	●	-	D	-	-									
JUNCTION	J-1	ELEVATOR MACHINE			●	-	-	-	-	-	-	-	-	-	-	●	-	D	-	-									

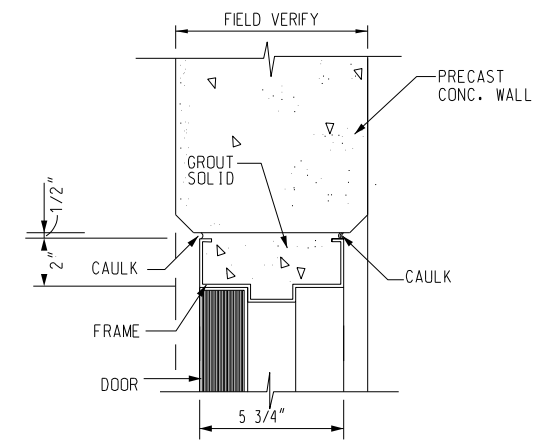

1 DOOR HEAD  
A505 SCALE: 3" = 1'-0"

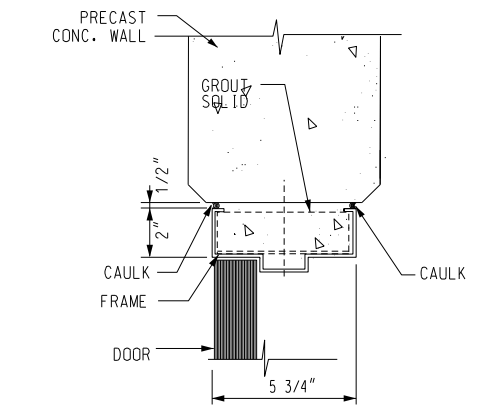

2 JAMB DET.  
A505 SCALE: 3" = 1'-0"

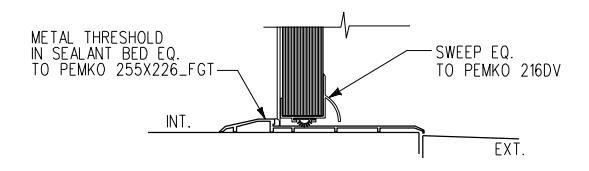

3 EXTERIOR THRESHOLD  
A505 SCALE: 3" = 1'-0"

DOOR HARDWARE DESCRIPTION						
DESG.	FUNCTION	DESCRIPTION	OUTSIDE LEVER		INSIDE LEVER	
			LOCKED BY	UNLOCKED BY	LOCKED BY	UNLOCKED BY
● P	PASSAGE	TURNING THE INSIDE LEVER, OR ROTATING THE OUTSIDE LEVER	CANNOT BE LOCKED	ALWAYS UNLOCKED	CANNOT BE LOCKED	ALWAYS UNLOCKED
● D	STOREROOM	TURNING THE KEY IN THE OUTSIDE LEVER, OR ROTATING THE INSIDE LEVER	ALWAYS FIXED	CANNOT BE UNLOCKED	CANNOT BE LOCKED	ALWAYS UNLOCKED

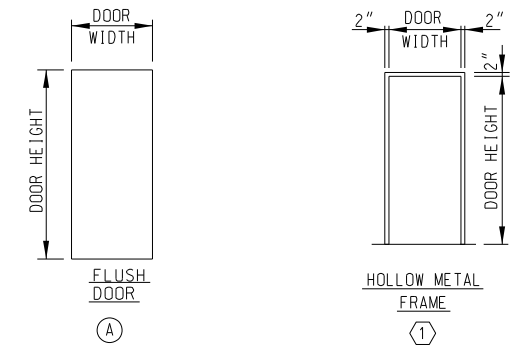

1 DOOR AND FRAME TYPE  
A505 NOT TO SCALE

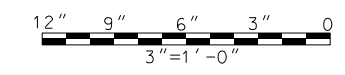

SCALES SHOWN FOR 22" X 34" SHEET. ADJUST SCALES FOR OTHER SIZES. PAGE OF

**WileyWilson**  
5901 Peachtree Dunwoody Rd.  
Bldg. C, Ste 515  
Atlanta, Georgia 30328-6055  
678.320.1888  
wileywilson.com  
WW JOB NUMBER: 219075.00

REV	APPROVED DATE	DESCRIPTION	JCN	REDLINE DATE	APVD
DEPARTMENT OF TRANSPORTATION FEDERAL AVIATION ADMINISTRATION					
FORT LAUDERDALE AIRPORT TRAFFIC CONTROL TOWER MAJOR IMPROVEMENTS ARCHITECTURAL DOOR TYPES, SCHEDULE AND DETAILS					
FT LAUDERDALE (INTERNATIONAL)			FL		
REVIEWED BY	SUBMITTED BY		APPROVED BY		
DESIGNED	GMR	ISSUED BY	APPROVER'S TITLE - MANAGER		
DRAWN	GMR	ATLANTA TERMINAL ENGINEERING CENTER	DATE	JAN 31, 2020	JCN 1508912
CHECKED	NXE		DRAWING NO	FLL-D-TRACO-A505	

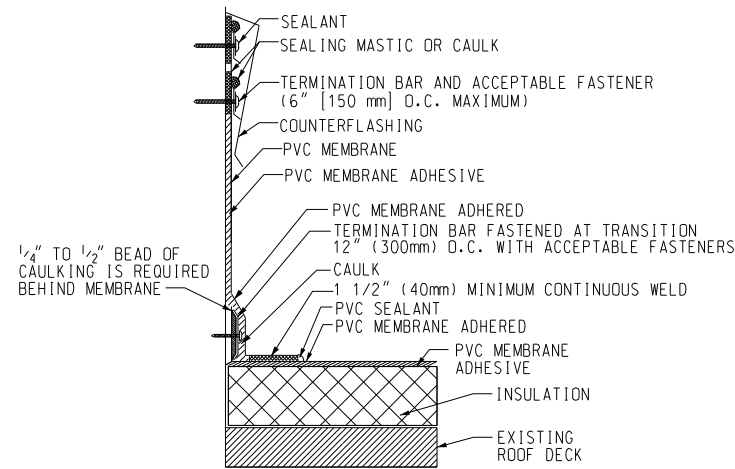

1 VERTICAL FLASHING DETAIL  
A610 NOT TO SCALE

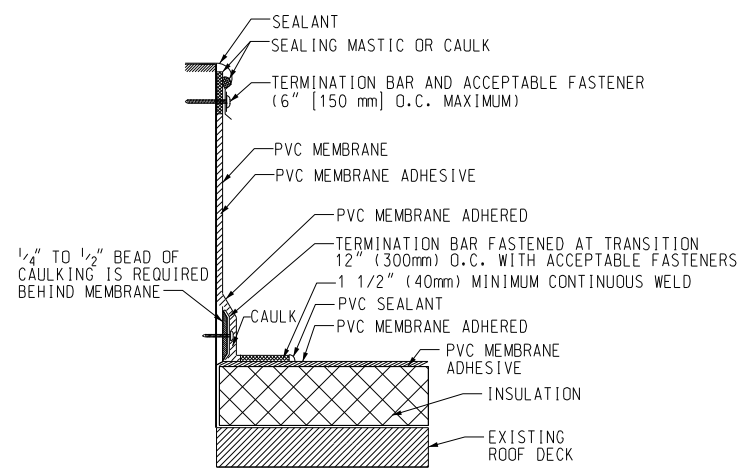

2 OUTSIDE FLASHING DETAIL  
A610 NOT TO SCALE

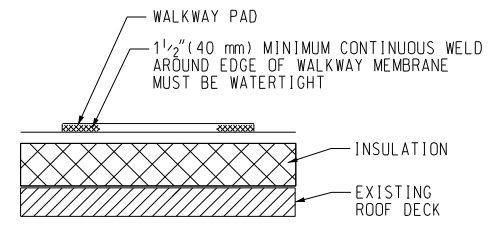

3 WALKWAY PAD DETAIL  
A610 NOT TO SCALE

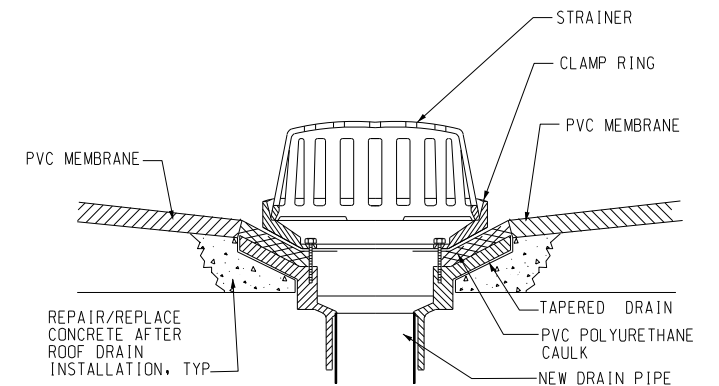

4 DRAIN DETAIL  
A610 SCALE: NONE

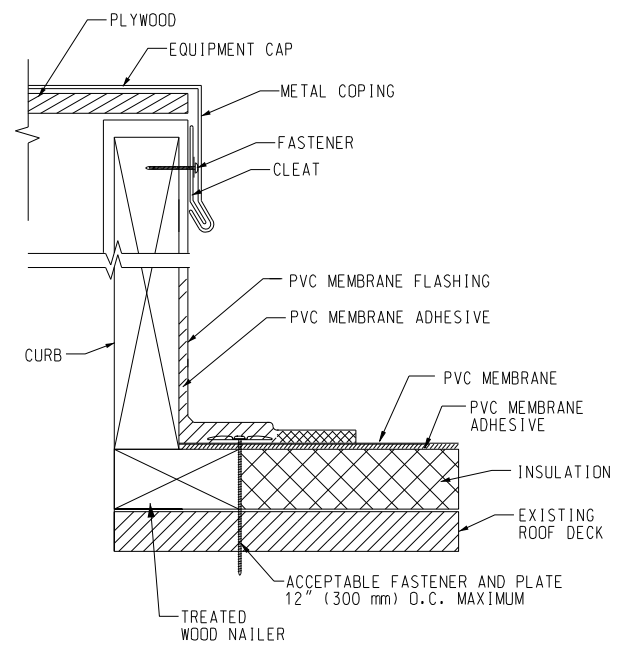

5 CURB CAP DETAIL  
A610 NOT TO SCALE

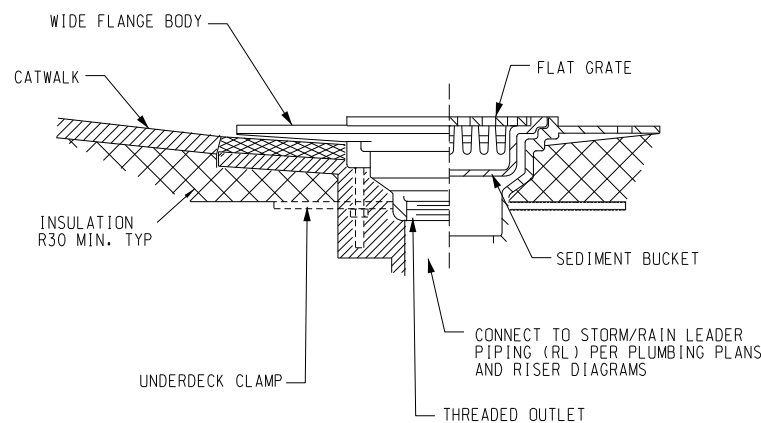

6 DRAIN AND SUMP DETAIL  
A610 NOT TO SCALE

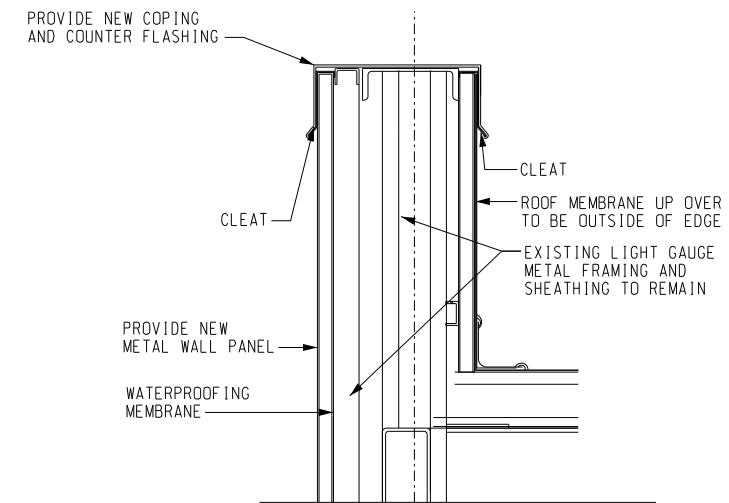

7 CAB PARAPET DETAIL  
A610 NOT TO SCALE

SCALES SHOWN FOR 22" X 34" SHEET. ADJUST SCALES FOR OTHER SIZES.				PAGE	OF
REV	APPROVED DATE	DESCRIPTION	JCN	REDLINE DATE	APVD
DEPARTMENT OF TRANSPORTATION FEDERAL AVIATION ADMINISTRATION  FORT LAUDERDALE AIRPORT TRAFFIC CONTROL TOWER MAJOR IMPROVEMENTS ARCHITECTURE CATWALK AND CAB ROOF DETAILS  FT LAUDERDALE (INTERNATIONAL) FL					
REVIEWED BY		SUBMITTED BY		APPROVED BY	
DESIGNED		SUBMITTER'S TITLE - CIVIL ENGINEER		APPROVER'S TITLE - MANAGER	
DRAWN		ISSUED BY		DATE JAN 31, 2020 JCN 1508912	
CHECKED		ATLANTA TERMINAL ENGINEERING CENTER		DRAWING NO. FLL-D-ATCT-A610	
WILEY WILSON 5901 Peachtree Dunwoody Rd. Bldg. C, Ste 515 Atlanta, Georgia 30328-6055 678.320.1888 wileywilson.com  WW JOB NUMBER: 219075.00					



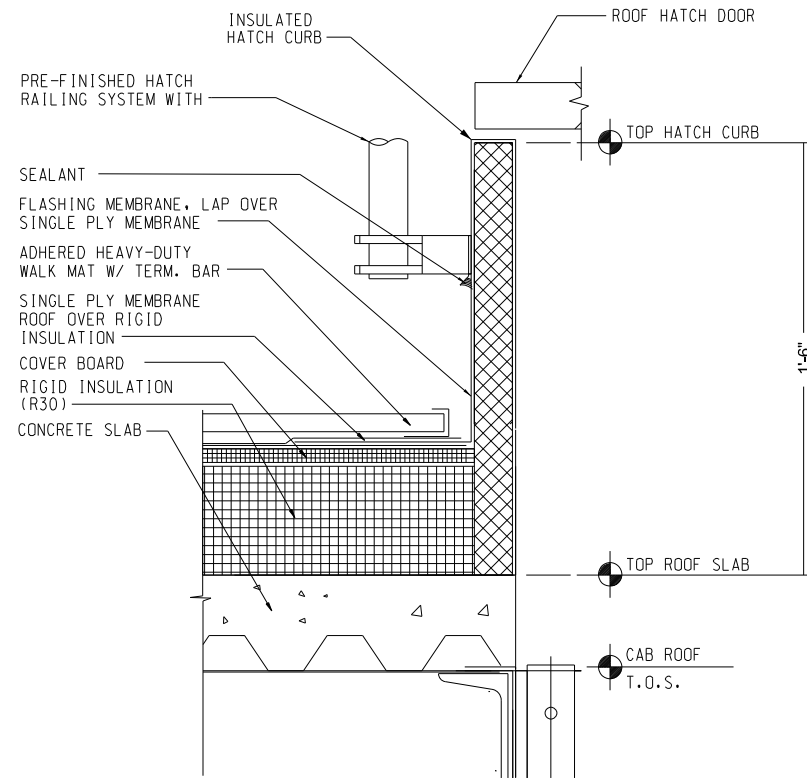

1 ROOF HATCH CURB DETAILS  
A611 NOT TO SCALE

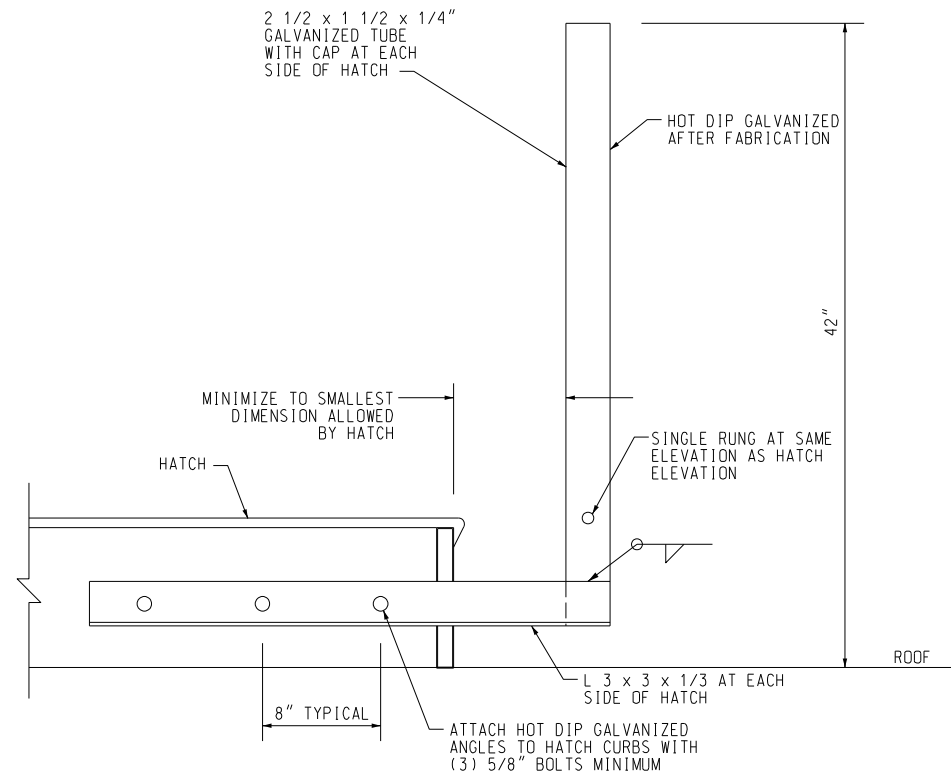

2 GRAB BARS ATTACHED TO HATCH FRAME  
A611 NOT TO SCALE

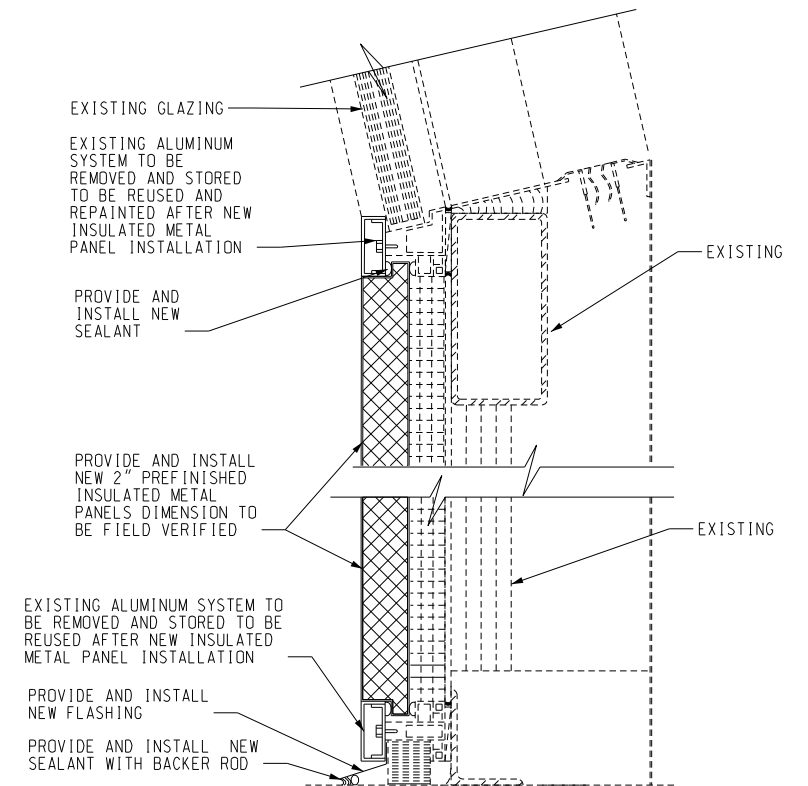

3 METAL PANEL DETAIL  
A611 SCALE: 3" = 1' - 0"

INSULATED METAL PANEL NOTES

- CONTRACTOR SHALL COORDINATE WITH FAA COR IF EXISTING CONDITIONS ARE NOT DEPICTED IN DRAWINGS.
- INSULATED METAL PANEL DETAIL SHOWN IS DIAGRAMMATIC ONLY. THE INTENT OF THIS DRAWING IS FOR THE CONTRACTOR TO PROVIDE A COMPLETE INSULATED METAL PANEL SYSTEM, INCLUDING FULLY ENGINEERED CONNECTIONS AND ATTACHMENT FURNISHED BY A SINGLE SUB-CONTRACTOR, AS PER THE REQUIREMENTS OF THE SPECIFICATIONS.
- PROVIDE INSULATED METAL PANELS (R-20 MIN.), EQUAL TO CENTRIA, DESIGNED TO COMPLY WITH THE HIGH VELOCITY HURRICANE ZONE OF THE FLORIDA BUILDING CODE. PROVIDE EVIDENCE OF PRODUCT CURRENT OF MIAMI-DADE COUNTY BUILDING CODE COMPLIANCE OFFICE.

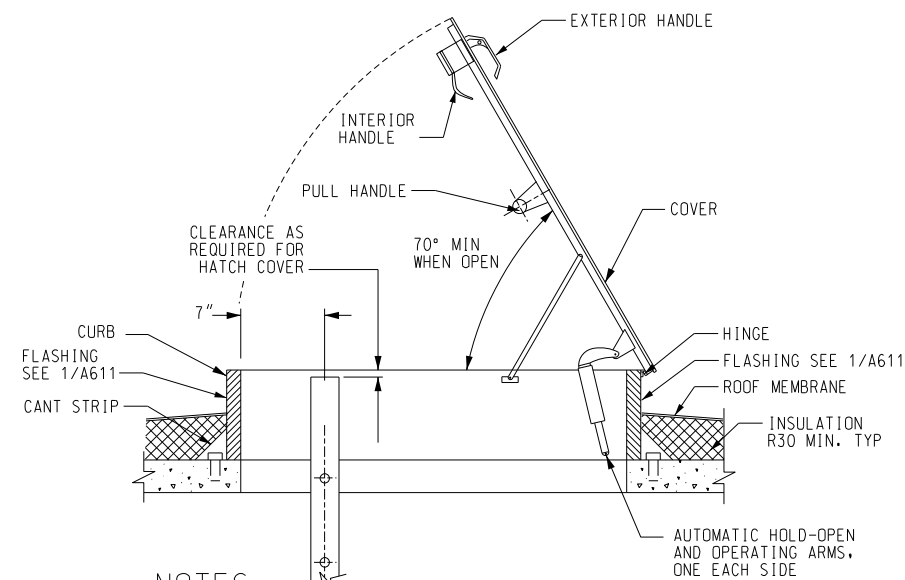

NOTES

- HATCH WIDTH 24" MIN FROM FACE - FACE OF OPERATING ARMS.
- GRAB BAR NOT SHOWN FOR CLARITY.

3 COUNTERBALANCED HATCH COVER AT ROOF  
A611 NOT TO SCALE

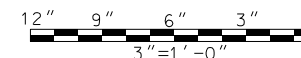

REV	APPROVED DATE	DESCRIPTION	JCN	REDLINE DATE	APVD
SCALES SHOWN FOR 22" X 34" SHEET. ADJUST SCALES FOR OTHER SIZES.					
DEPARTMENT OF TRANSPORTATION FEDERAL AVIATION ADMINISTRATION					
FORT LAUDERDALE AIRPORT TRAFFIC CONTROL TOWER MAJOR IMPROVEMENTS ARCHITECTURE CATWALK HATCH AND CAB DETAILS					
FT LAUDERDALE			(INTERNATIONAL)		FL
REVIEWED BY	SUBMITTED BY		APPROVED BY		
SUBMITTER'S TITLE - CIVIL ENGINEER		APPROVER'S TITLE - MANAGER			
DESIGNED	GMR	ISSUED BY	DATE	JCN	
DRAWN	GMR	ATLANTA TERMINAL ENGINEERING CENTER	JAN 31, 2020	1508912	
CHECKED	NXE		DRAWING NO	FLL-D-ATCT-A611	
WILEY WILSON 5901 Peachtree Dunwoody Rd. Bldg. C, Ste 515 Atlanta, Georgia 30328-6055 678.320.1888 wileywilson.com WW JOB NUMBER: 219075.00					

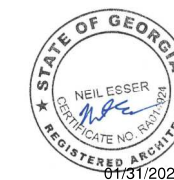

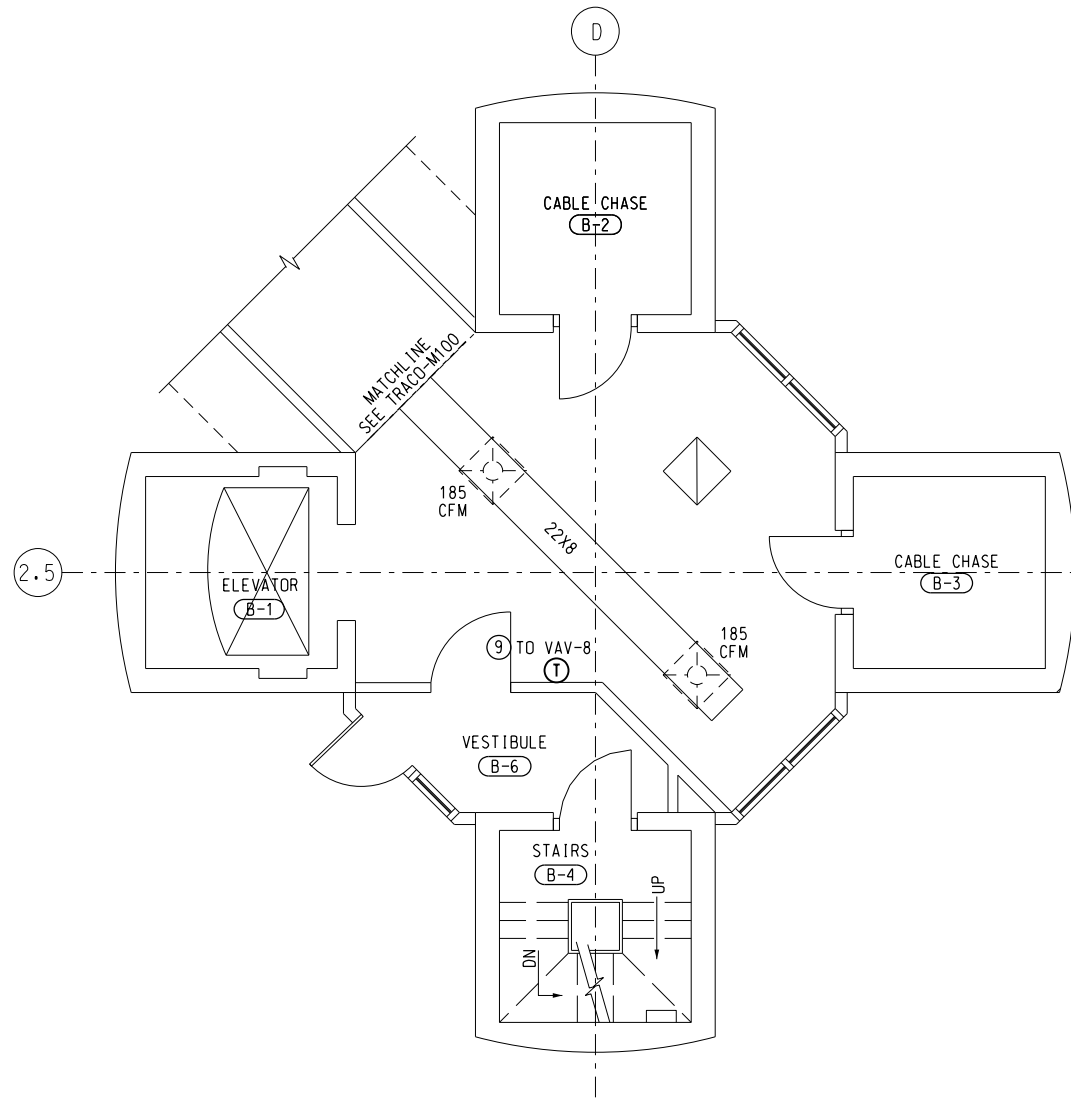

**1** GROUND LEVEL PLAN - HVAC  
M100 SCALE: 1/4" = 1'-0"

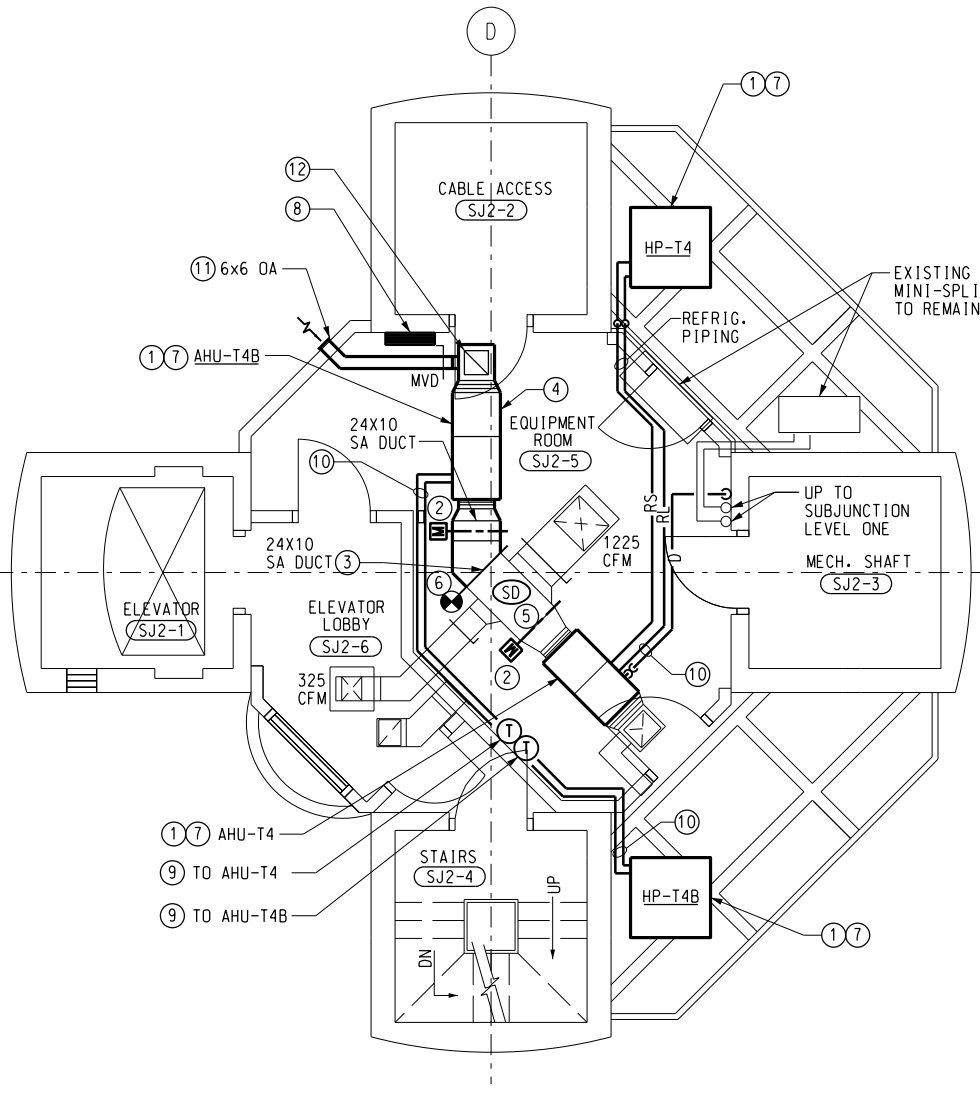

**2** SUBJUNCTION LEVEL TWO PLAN - HVAC  
M100 SCALE: 1/4" = 1'-0"



**NOTES**

- ① SEE CONTROL DRAWINGS FOR NEW CONTROLS.
- ② NEW MOTOR-OPERATED DAMPERS WITH NEW MOTOR ACTUATORS AND CONTROLS. SEE CONTROLS DIAGRAMS FOR DETAILS.
- ③ SEE DETAIL 4 ON DRAWING M601(TRACO) FOR DUCT INSTALLATION DETAILS.
- ④ RELOCATE CONDUIT, SPLICE AND PATCH TO EXPAND WHERE NECESSARY, SEE ELECTRICAL FOR DETAILS.
- ⑤ NEW SMOKE DETECTOR IN SUPPLY DUCT. SEE CONTROL DRAWINGS FOR DETAILS.
- ⑥ REMOVE END OF DUCT AND FASTEN NEW DUCT TO EXISTING. SEAL AIR-TIGHT.
- ⑦ INSTALL NEW AHU-T4 AND HP-T4, AHU-T4B AND HP-T4B.
- ⑧ INSTALL NEW DDC CONTROL PANEL FOR UNITS AHU-T4, T4B.
- ⑨ INSTALL NEW THERMOSTAT TO BE INTERLOCKED WITH NEW DDC CONTROLS.
- ⑩ NEW LINESET.
- ⑪ INSTALL NEW OUTDOOR AIR DUCT ROUTED TO WALL WITH WALLCAP, WALLCAP SHALL BE EQUIPPED WITH BIRDSCREEN AND BACKFLOW DAMPER.
- ⑫ INSTALL NEW RETURN AIR GRILLE IDENTICAL TO THAT WHICH IS EXISTING. BOD SHALL BE TITOS 50F. WITH 18x18 NECK.

**GENERAL**

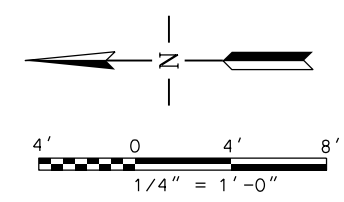
- A. NEW WORK IS SHOWN AS HEAVY LINE ON PLANS AND EXISTING WORK SHOWN IS LIGHT SOLID LINE.
- B. CONTRACTOR SHALL PERFORM AIR FLOW TEST AND REBALANCE ALL EXISTING AND NEW AIR DEVICES TO AIR FLOW INDICATED.
- C. PROVIDE NEW SPLIT SYSTEM (AHU/HP) WALL MOUNTED THERMOSTATS AS INDICATED, AND ASSOCIATED CONTROLS.
- D. WHERE NEW CONNECTION TO EXISTING IS INDICATED, THE CONTRACTOR SHALL FIELD VERIFY THE SIZE AND EXACT LOCATION OF THE EXISTING WORK AT THE POINT OF CONNECTION. NEW DUCT AND PIPE SIZE SHALL MATCH THE EXISTING.
- E. ALL NEW EXPOSED DUCTWORK SHALL BE INSULATED DOUBLE WALL DUCT AS PER SPECIFICATIONS, UNLESS OTHERWISE NOTED.
- G. SEE DRAWING TRACC-M000 FOR HVAC LEGEND, GENERAL NOTES AND SPECIAL NOTES.



SCALES SHOWN FOR 22" X 34" SHEET. ADJUST SCALES FOR OTHER SIZES.		PAGE	OF
			
<b>DEPARTMENT OF TRANSPORTATION FEDERAL AVIATION ADMINISTRATION</b>			
<b>FORT LAUDERDALE AIRPORT TRAFFIC CONTROL TOWER MAJOR IMPROVEMENTS MECHANICAL GROUND LEVEL AND SUBJUNCTION LEVEL 2 - HVAC</b>			
FT LAUDERDALE		(INTERNATIONAL) FL	
REVIEWED BY	SUBMITTED BY	APPROVED BY	
SUBMITTER'S TITLE - CIVIL ENGINEER		APPROVER'S TITLE - MANAGER	
DESIGNED	JJS	ISSUED BY	DATE JAN 31, 2020 JCN 1508912
DRAWN	CRK	ATLANTA TERMINAL ENGINEERING CENTER	DRAWING NO
CHECKED	JJS		FLL-D-ATCT- M100
 <b>WileyWilson</b> 5901 Peachtree Dunwoody Rd. Bldg. C, Ste 515 Atlanta, Georgia 30328-6055 678.320.1888 wileywilson.com WW JOB NUMBER: 219075.00			

**NOTES**

- ① SEE CONTROL DRAWINGS FOR NEW CONTROLS.
- ② NEW MOTOR-OPERATED DAMPERS WITH NEW MOTOR ACTUATORS AND CONTROLS. SEE CONTROLS DIAGRAMS FOR DETAILS.
- ③ SEE DETAILS 2 AND 3 ON DRAWING TRACO-M602 FOR INSTALLATION DETAILS.
- ④ RELOCATE CONDUIT, SPLICE AND PATCH TO EXPAND NECESSARY, SEE ELECTRICAL FOR DETAILS.
- ⑤ NEW SMOKE DETECTOR IN SUPPLY DUCT. SEE CONTROL DRAWINGS FOR DETAILS.
- ⑥ REMOVE DUCT CAP AND MAKE NEW DUCT TO EXISTING. SEAL AIR TIGHT.
- ⑦ INSTALL 8X8 DUCTWORK BETWEEN EXISTING OA INTAKE AND RA DUCT. NEW OA DUCT SHALL BE INSULATED WITH R-8 WRAP AND UNSTALL PER SPECIFICATIONS. SEAL DUCT CONNECTIONS AND FITTINGS AIR-TIGHT. INSTALL MANUAL VOLUME DAMPER WHERE OA DUCT CONNECTS TO MIXED AIR PLENUM. PROVIDE TRANSITION FITTINGS BETWEEN INTAKE AND OA DUCTWORK.
- ⑧ INSTALL NEW DDC CONTROL PANEL FOR AHU-T1 AND T1B. COORDINATE WITH ELECTRICAL.
- ⑨ INSTALL NEW DDC CONTROL PANEL FOR AHU-T2 AND T3. COORDINATE WITH ELECTRICAL.
- ⑩ INSTALL NEW THERMOSTAT TO BE INTERGRATED PROVIDE WITH NEW DDC CONTROLS.
- ⑪ NEW LINESET.
- ⑫ INSTALL NEW OUTDOOR AIR DUCT ROUTED TO WALL WITH WALLCAP, WALLCAP EQUIPPED WITH BIRDSCREEN AND BACKFLOW DAMPER.
- ⑬ INSTALL NEW RETURN AIR GRILLE IDENTICAL TO EXISTING. BOD SHALL BE TITOS 50F. WITH 18X18 NECK.
- ⑭ INSTALL NEW SPLIT SYSTEM, AHU/HP-T1 AND AHU/HP-T1B.

**GENERAL**

- A. NEW WORK IS SHOWN AS HEAVY LINE ON PLANS AND EXISTING WORK SHOWN IS LIGHT SOLID LINE.
- B. CONTRACTOR SHALL PERFORM AIR FLOW TEST AND REBALANCE ALL EXISTING AND NEW AIR DEVICES TO AIR FLOW INDICATED.
- C. WHERE NEW CONNECTION TO EXISTING IS INDICATED, THE CONTRACTOR SHALL FIELD VERIFY THE SIZE AND EXACT LOCATION OF THE EXISTING WORK AT THE POINT OF CONNECTION. NEW DUCT AND PIPE SIZE SHALL MATCH THE EXISTING.
- D. ALL NEW EXPOSED DUCTWORK SHALL BE INSULATED DOUBLE WALL DUCT AS PER SPECIFICATIONS, UNLESS OTHERWISE NOTED.
- E. SEE DRAWING TRACO-M000 FOR HVAC LEGEND, GENERAL NOTES AND SPECIAL NOTES.

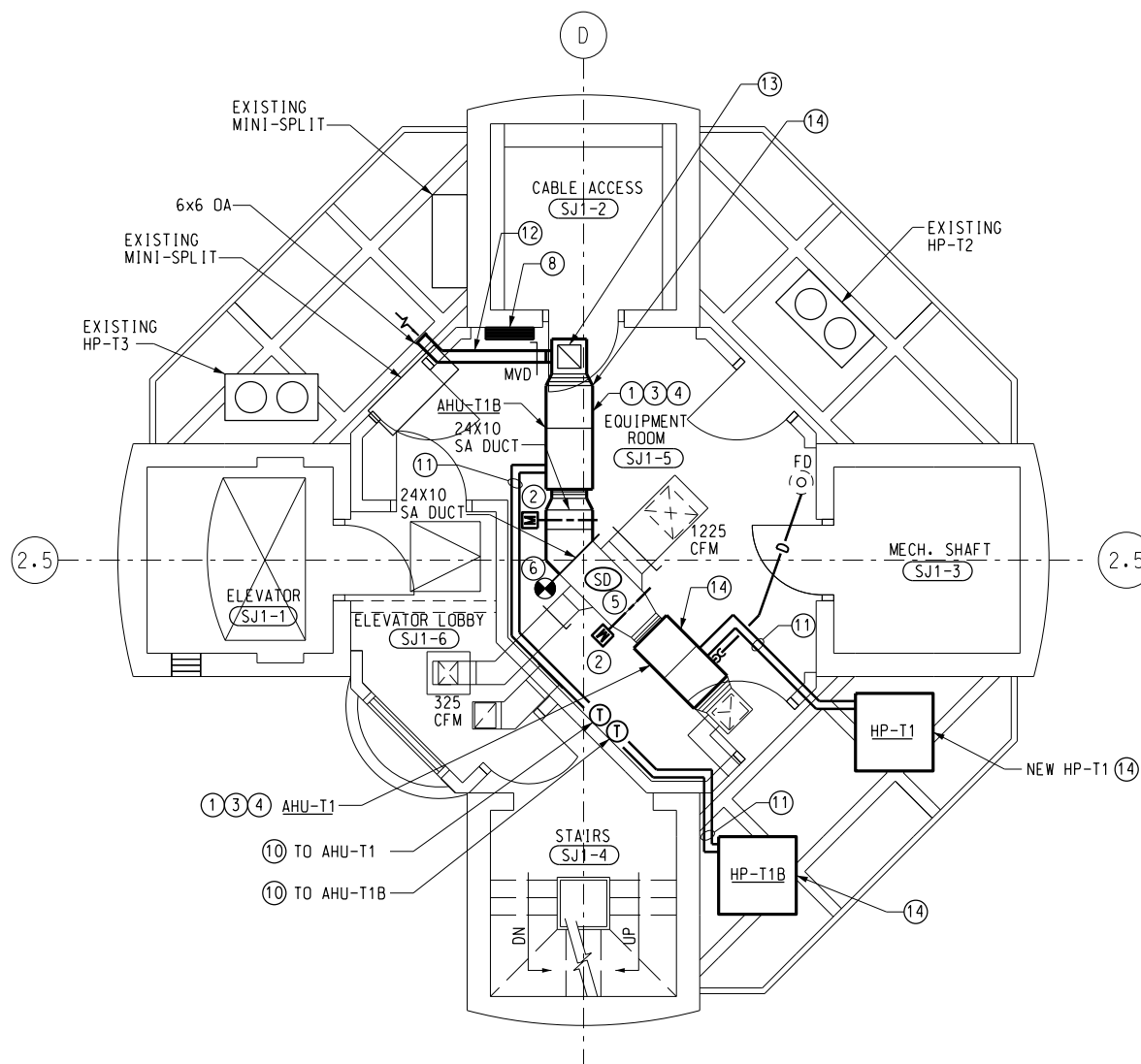

**1** SUBJUNCTION LEVEL 1 PLAN - HVAC  
M101 SCALE: 1/4" = 1'-0"

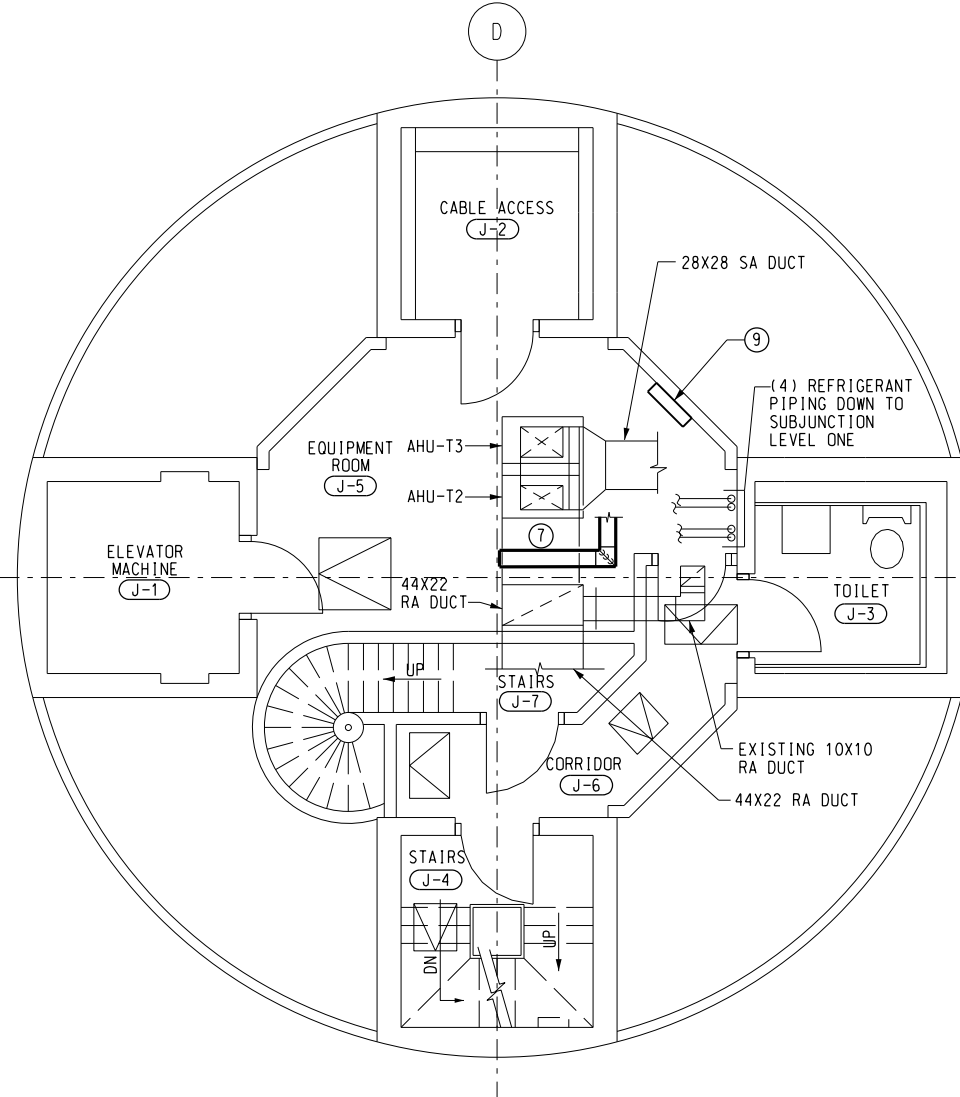

**2** JUNCTION LEVEL PLAN - HVAC  
M101 SCALE: 1/4" = 1'-0"

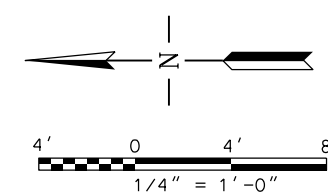



SCALES SHOWN FOR 22" X 34" SHEET. ADJUST SCALES FOR OTHER SIZES.		PAGE	OF
			
DEPARTMENT OF TRANSPORTATION FEDERAL AVIATION ADMINISTRATION			
FORT LAUDERDALE AIRPORT TRAFFIC CONTROL TOWER MAJOR IMPROVEMENTS MECHANICAL SUBJUNCTION LEVEL 1 AND JUNCTION LEVEL - HVAC			
FT LAUDERDALE		(INTERNATIONAL) FL	
REVIEWED BY	SUBMITTED BY	APPROVED BY	
SUBMITTER'S TITLE - CIVIL ENGINEER		APPROVER'S TITLE - MANAGER	
DESIGNED BY	JJS	ISSUED BY	DATE JAN 31, 2020 JCN 1508912
DRAWN BY	CRK	ATLANTA TERMINAL ENGINEERING CENTER	DRAWING NO
CHECKED BY	JJS		FLL-D-ATCT-M101
WILEY WILSON 5901 Peachtree Dunwoody Rd. Bldg. C, Ste 515 Atlanta, Georgia 30328-6055 678.320.1888 wileywilson.com WW JOB NUMBER: 219075.00			

**SPLIT SYSTEM HEAT PUMP SCHEDULE**

AIR HANDLING UNIT (INDOOR)														HEAT PUMP UNIT (OUTDOOR)															
AIRFLOW					COIL PERFORMANCE								ELECTRIC HEAT				ELECTRIC DATA												
MARK	SA CFM	OA CFM	ESP (IN WG)	FAN HP	COOLING @ 95°F AMBIENT				HEATING @ 47°F				kW	ELECTRIC DATA			LOCATION	MAKE AND MODEL	MARK	MINIMUM SEER	HSPF	ELECTRIC DATA			UNIT AMPACITY (AMP)	LOCATION	MAKE AND MODEL	REMARKS	
					TOTAL CAPACITY (MBH)	SENSIBLE CAPACITY (MBH)	EAT DB (°F)	EAT WB (°F)	LAT F (DB)	LAT F (WB)	CAPACITY, HIGH (MBH)	EAT (°F)		LAT (°F)	VOLTS	PH						HZ	VOLTS	PH					HZ
AHU-T1	1681	100	0.7	0.75	54.8	38.5	80	67	58.8	56.7	60.7	70	103	7.2	208	1	60	EQUIPMENT ROOM, SUBJUNCTION ONE	YORK AE60DX21	HP-T1	14	8.2	208	3	60	21.22	PLATFORM, SUBJUNCTION TWO	YORK THE60B315	① THRU ⑱
AHU-T1B	1681	100	0.7	0.75	54.8	38.5	80	67	58.8	56.7	60.7	70	103	7.2	208	1	60	EQUIPMENT ROOM, SUBJUNCTION ONE	YORK AE60DX21	HP-T1B	14	8.2	208	3	60	21.22	PLATFORM, SUBJUNCTION TWO	YORK THE60B315	① THRU ⑱
AHU-T4	1681	100	0.7	0.75	54.8	38.5	80	67	58.8	56.7	60.7	70	103	7.2	208	1	60	EQUIPMENT ROOM, SUBJUNCTION TWO	YORK AE60DX21	HP-T4	14	8.2	208	3	60	21.22	PLATFORM, SUBJUNCTION TWO	YORK THE60B315	① THRU ⑱
AHU-T4B	1681	100	0.7	0.75	54.8	38.5	80	67	58.8	56.7	60.7	70	103	7.2	208	1	60	EQUIPMENT ROOM, SUBJUNCTION TWO	YORK AE60DX21	HP-T4B	14	8.2	208	3	60	21.22	PLATFORM, SUBJUNCTION TWO	YORK THE60B315	① THRU ⑱

- ① MAINTAIN MANUFACTURER'S RECOMMEND CLEARANCES FOR SERVICE AND AIRFLOW.
- ② SPLIT SUBMITTAL'S SHALL INCLUDE DATA ON LINESET LENGTH LIMITATIONS AND DE-RATING VALUES THEREIN.
- ③ SELECTIONS SHALL BE BASED ON CAPACITIES AND NOT NOMINAL TONNAGE LISTED FOR REFERENCE ONLY.
- ④ COOLING CAPACITIES BASED ON 95 DEGREE AMBIENT AIR TEMPERATURE, 80 DEGREES DB EAT, AND 67 DEGREES WB EAT.
- ⑤ ELECTRIC STRIP HEAT BASED ON SCHEDULED CFM VALUES AND A 13 DEGREE DELTA-T.
- ⑥ HEAT PUMPS SHALL BE PROVIDED WITH NECESSARY KIT AND ACCESSORIES FOR LOW -AMBIENT COOLING OPERATION.
- ⑦ MOUNT INDOOR UNIT FROM STRUCTURE PER FEMA SEISMIC REQUIREMENTS.
- ⑧ PROVIDE FIELD POWERED CONVENIENCE OUTLET.
- ⑨ PROVIDE SMOKE DETECTOR IN FAN COIL UNIT SUPPLY DUCT. SMOKE DETECTOR SHALL BE INTERLOCKED TO FIRE PROTECTION CONTROLS. CONTRACTOR SHALL PROVIDE AND COORDINATE WITH FIRE PROTECTION CONTRACTOR.
- ⑩ PROVIDE WITH THERMOSTAT/HUMIDISTAT TO BE INTEGRATED WITH DDC SYSTEM. MOUNT THERMOSTAT MIN. 48" AFF. THERMOSTAT/HUMIDISTAT SHALL BE PASSWORD PROTECTED OR TAMPER-PROOF. SEE CONTROLS DRAWINGS FOR SETTINGS.

- ①① PROVIDE THERMOSTATIC EXPANSION VALVE.
- ①② PROVIDE WITH CONDENSATE OVERFLOW SWITCH. SWITCH SHALL SHUT DOWN UNIT AND INDICATE ALARM IN DDC. SEE CONTROL DRAWINGS.
- ①③ PROVIDE WITH CONDENSATE PUMP CAPABLE OF 10 FT. HD AND 25 GPH, BOD: LITTLE GIANT VCMA-15UL.
- ①④ PROVIDE SECONDARY CORROSION-RESISTANT DRAIN PAN.
- ①⑤ SHOP DRAWINGS SHALL INCLUDE COMBINATION RATINGS.
- ①⑥ PROVIDE MODINE ELECTROFIN E-COAT ON CONDENSER AND EVAPORATOR COILS.
- ①⑦ PROVIDE NEW DDC CONTROL PANEL PER PLANS. COORDINATE POWER REQUIREMENTS WITH ELECTRICAL AND WITH CONTROLS CONTRACTOR.
- ①⑧ PROVIDE ELECTRICAL DISCONNECT. COORDINATE WITH ELECTRICAL.

SCALES SHOWN FOR 22" X 34" SHEET. ADJUST SCALES FOR OTHER SIZES.		PAGE	OF
			
			
5901 Peachtree Dunwoody Rd. Bldg. C, Ste 515 Atlanta, Georgia 30328-6055 678.320.1888 wileywilson.com WW JOB NUMBER: 219075.00			
REV	APPROVED DATE	DESCRIPTION	JCN
DEPARTMENT OF TRANSPORTATION FEDERAL AVIATION ADMINISTRATION FORT LAUDERDALE AIRPORT TRAFFIC CONTROL TOWER MAJOR IMPROVEMENTS MECHANICAL HVAC SCHEDULES FT LAUDERDALE (INTERNATIONAL) FL			
REVIEWED BY	SUBMITTED BY	APPROVED BY	
SUBMITTER'S TITLE - CIVIL ENGINEER		APPROVER'S TITLE - MANAGER	
DESIGNED	JJS	ISSUED BY	DATE JAN 31, 2020 JCN 1508912
DRAWN	CRK	ATLANTA TERMINAL ENGINEERING CENTER	DRAWING NO
CHECKED	JJS		FLL-D-ATCT-M500



**NOTES**

1. SEE DRAWING TRACO-M000 FOR HVAC LEGEND AND GENERAL NOTES.
2. THE SMOKE DETECTOR AND FIRE ALARM CONTROL MODULES SHALL BE FURNISHED AND INSTALLED BY FIRE ALARM CONTRACTOR.
3. INSTRUMENT NUMBER ASSIGNMENTS ARE OMITTED WHEN DIAGRAMS APPLY TO MULTIPLE SYSTEMS/ EQUIPMENT. CONTRACTOR SHALL ASSIGN THEM.

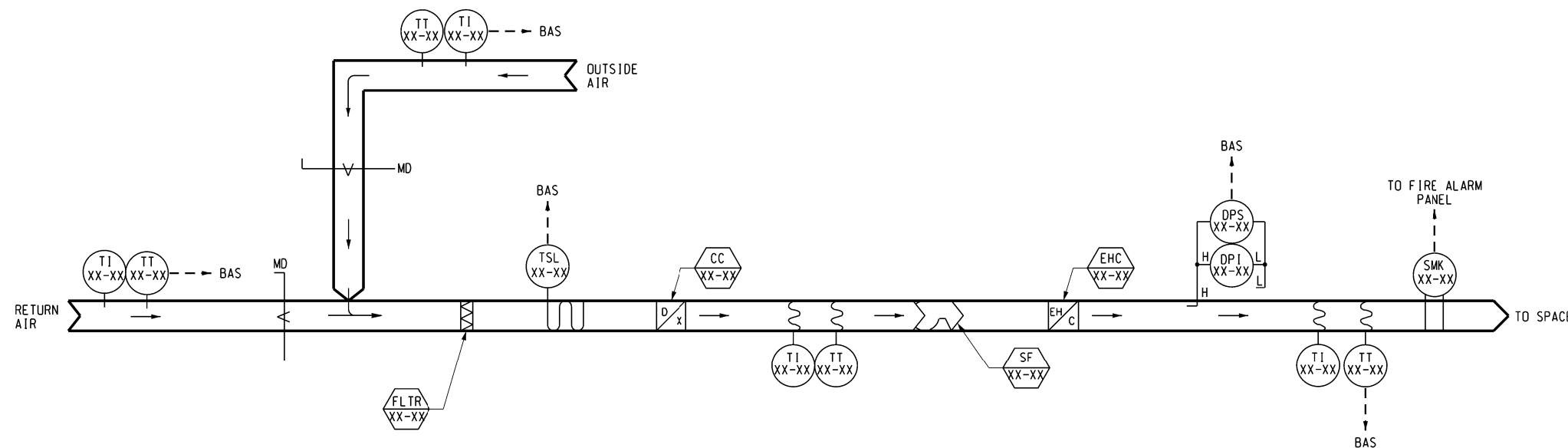

**1** CONTROL SYSTEM DIAGRAM - AHUs-T1/T1B, T4/T4B  
 M800 NOT TO SCALE

SCALES SHOWN FOR 22" X 34" SHEET. ADJUST SCALES FOR OTHER SIZES. PAGE OF

<p><b>WileyWilson</b>                  5901 Peachtree Dunwoody Rd.                  Bldg. C, Ste 515                  Atlanta, Georgia 30328-6055                  678.320.1888                  wileywilson.com                  WW JOB NUMBER: 219075.00</p>	REV	APPROVED DATE	DESCRIPTION	JCN	REDLINE DATE	APVD	
	DEPARTMENT OF TRANSPORTATION FEDERAL AVIATION ADMINISTRATION						
	FORT LAUDERDALE AIRPORT TRAFFIC CONTROL TOWER MAJOR IMPROVEMENTS MECHANICAL CONTROL SYSTEM DIAGRAM AHUs-T1/T1B, T4/T4B						
	FT LAUDERDALE (INTERNATIONAL) FL						
DESIGNED	JJS	ISSUED BY	ATLANTA TERMINAL ENGINEERING CENTER	DATE	JAN 31, 2020	JCN	1508912
DRAWN	CRK	CHECKED	JJS	DRAWING NO	FLL-D-ATCT-M800		REV

**GENERAL**

- THE NEW HVAC CONTROL SYSTEM SHALL BE DIRECT DIGITAL CONTROL (DDC) SYSTEM, "SMARTSTRUXURE" AS MANUFACTURED BY SCHNEIDER ELECTRIC.
- NEW THERMOSTATS SHALL BE SCHNEIDER ELECTRIC STR 250, WALL-MOUNTED ALPHANUMERIC DISPLAY WITH ADJUSTABLE DDC DETERMINED DEADBAND.
- PROVIDE A NEW DDC CENTRAL WORKSTATION WHERE DIRECTED BY THE FAA CONTRACTING OFFICER REPRESENTATIVE.

**SEQUENCE OF OPERATION: AHU/HP-T2, AHU/HP-T3 (EXISTING)**

- AHU AND ASSOCIATED HP SHALL BE STARTED AND CONTROLLED DIRECTLY BY A PANEL MOUNTED PROCESS CONTROL UNIT. THE PCU SHALL CONTROL OPERATION OF THE HEAT PUMP SUPPLY FAN, CONDENSING UNIT, REVERSING VALVE AND SUPPLEMENTAL HEAT TO MAINTAIN SPACE TEMPERATURE CONDITIONS AS MEASURED BY SPACE TEMPERATURE SENSORS LOCATED IN THE CAB. THE ISOLATION DAMPERS IN THE SUPPLY AND RETURN WILL BE INTERLOCKED WITH THE SUPPLY FAN.
- AHU-T2/HP-T2 AND AHU-T3/HP-T3 ARE TWO UNITS SERVING THE SAME AREA. DDC SYSTEM SHALL ASSIGN ONE SYSTEM "PRIMARY" RESPONSIBILITY AND THE OTHER SYSTEM "STANDBY" RESPONSIBILITY AND SHALL REVERSE THE ASSIGNMENT BI-MONTHLY TO EQUALIZE RUN-TIME ACCUMULATION. REASSIGNMENT OF PRIMARY AND STANDBY STATUS SHALL NOT OCCUR IF A SYSTEM FAILURE FLAG IS SET. THE PRIMARY SYSTEM SHALL OPERATE TO MAINTAIN SPACE CONDITIONS. IF THE SPACE TEMPERATURE SETPOINT IS NOT REACHED AFTER TEN MINUTES (ADJUSTABLE) OF CONTINUOUS OPERATION OF THE PRIMARY SYSTEM, THE DDC SYSTEM SHALL STOP THE PRIMARY SYSTEM AND REVERSE THE PRIMARY AND STANDBY ASSIGNMENTS. THE NEWLY DESIGNATED PRIMARY SYSTEM SHALL BE STARTED. THE DDC SYSTEM SHALL SEND AN ALARM AND SHALL SET A FAILURE FLAG FOR THE STOPPED SYSTEM.
- ISOLATION DAMPERS IN THE SUPPLY AND RETURN SHALL BE INTERLOCKED WITH THEIR RESPECTIVE SUPPLY FAN AND SHALL OPEN BEFORE THE SUPPLY FAN IS STARTED AND CLOSE WHEN THE FAN IS STOPPED. THE FAN MOTOR OPERATION SHALL BE CONTROLLED BY DAMPER END POSITION SWITCHES.
- THE PROCESS CONTROL UNIT SHALL MONITOR THE SPACE CONDITIONS VIA A WALL MOUNTED THERMOSTAT (ADJUSTABLE). THE THERMOSTAT SHALL BE MOUNTED IN THE CAB IN A READILY ACCESSIBLE LOCATION.
- WHEN HUMIDITY RISES ABOVE THE SETPOINT (ADJUSTABLE) AS SENSED BY THE SPACE SENSOR, THE UNIT SHALL ENTER COOLING MODE AND SHALL CONTINUE UNTIL SUCH TIME AS THE HUMIDITY LEVELS ARE REDUCED TO LEVELS BELOW SETPOINT. IF SUBSEQUENT HEATING IS REQUIRED TO MAINTAIN SPACE TEMPERATURE SETPOINT, THE ELECTRIC HEATING COIL SHALL BE ENERGIZED AS REQUIRED TO MAINTAIN SPACE TEMPERATURE. WHEN SPACE HUMIDITY HAS BEEN REDUCED TO BELOW SETPOINT ELECTRIC HEATING AND COOLING MODE SHALL BE EXITED AND THE UNIT SHALL RESUME NORMAL OPERATION.
- SMOKE DETECTORS IN THE SUPPLY AIR AND RETURN AIR DUCTWORK SHALL STOP THE SUPPLY FAN AND INITIATE A SMOKE ALARM IF SMOKE IS DETECTED AT EITHER LOCATION. RESTARTING THE SUPPLY FAN SHALL REQUIRE MANUAL RESET AT THE SMOKE DETECTOR.

**SEQUENCE OF OPERATION (EXISTING EXHAUST FAN)**

- EXISTING EXHAUST FAN (INLINE CENTRIFUGAL TYPE SERVING THE TOILET ON JUNCTION LEVEL IN THE TOWER) SHALL BE CONTROLLED AND RUN STATUS MONITORED VIA THE DDC SYSTEM. FAN SHALL BE CONTROLLED TO RUN DURING OCCUPIED TIMES AS DETERMINED BY OPERATION OF AHU-T2 AND AHU-T3.

**SEQUENCE OF OPERATION: AHU/HP-T1, T1B, T4, T4B (NEW)**

- AHU AND ASSOCIATED HP SHALL BE STARTED AND CONTROLLED DIRECTLY BY A PANEL MOUNTED PROCESS CONTROL UNIT. THE PCU SHALL CONTROL OPERATION OF THE HEAT PUMP SUPPLY FAN, CONDENSING UNIT, REVERSING VALVE AND SUPPLEMENTAL HEAT TO MAINTAIN SPACE TEMPERATURE CONDITIONS AS MEASURED BY SPACE TEMPERATURE SENSORS LOCATED IN TOWER SUBJUNCTION LEVEL 1 AND SUBJUNCTION LEVEL 2. THE ISOLATION DAMPERS IN THE SUPPLY DUCTS SHALL BE INTERLOCKED WITH THE SUPPLY FAN.
- AHU/HP-T1/T1B AND AHU/HP-T4/T4B ARE TWO REDUNDANT SYSTEMS SERVING THEIR RESPECTIVE AREAS. DDC SYSTEM SHALL ASSIGN ONE SYSTEM "PRIMARY" RESPONSIBILITY AND THE OTHER SYSTEM "STANDBY" RESPONSIBILITY AND SHALL REVERSE THE ASSIGNMENT BI-MONTHLY TO EQUALIZE RUN-TIME ACCUMULATION. REASSIGNMENT OF PRIMARY AND STANDBY STATUS SHALL NOT OCCUR IF A SYSTEM FAILURE FLAG IS SET. THE PRIMARY SYSTEM SHALL OPERATE TO MAINTAIN SPACE CONDITIONS. IF THE SPACE TEMPERATURE SETPOINT IS NOT REACHED AFTER TEN MINUTES (ADJUSTABLE) OF CONTINUOUS OPERATION OF THE PRIMARY SYSTEM, THE DDC SYSTEM SHALL STOP THE PRIMARY SYSTEM AND REVERSE THE PRIMARY AND STANDBY ASSIGNMENTS. THE NEWLY DESIGNATED PRIMARY SYSTEM SHALL BE STARTED. THE DDC SYSTEM SHALL SEND AN ALARM AND SHALL SET A FAILURE FLAG FOR THE STOPPED SYSTEM.
- ISOLATION DAMPERS IN THE SUPPLY DUCTS SHALL BE INTERLOCKED WITH THEIR RESPECTIVE SUPPLY FANS. THE PROCESS CONTROL UNIT SHALL MONITOR THE SPACE CONDITIONS BY A WALL MOUNTED THERMOSTAT. THE THERMOSTAT SHALL BE LOCATED WITHIN THE SPACE AS SHOWN IN THE DRAWINGS.
- WHEN HUMIDITY RISES ABOVE THE SETPOINT (ADJUSTABLE) AS SENSED BY THE SPACE SENSOR, THE UNIT SHALL ENTER COOLING MODE AND SHALL CONTINUE UNTIL SUCH TIME AS THE HUMIDITY LEVELS ARE REDUCED TO LEVELS BELOW SETPOINT. IF SUBSEQUENT HEATING IS REQUIRED TO MAINTAIN SPACE TEMPERATURE SETPOINT, THE ELECTRIC HEATING COIL SHALL BE ENERGIZED AS REQUIRED TO MAINTAIN SPACE TEMPERATURE. WHEN SPACE HUMIDITY HAS BEEN REDUCED TO BELOW SETPOINT ELECTRIC HEATING AND COOLING MODE SHALL BE EXITED AND THE UNIT SHALL RESUME NORMAL OPERATION.
- ISOLATION DAMPERS IN THE SUPPLY AND RETURN SHALL BE INTERLOCKED WITH THEIR RESPECTIVE SUPPLY FAN AND SHALL OPEN BEFORE THE SUPPLY FAN IS STARTED AND CLOSE WHEN THE FAN IS STOPPED. THE FAN MOTOR OPERATION SHALL BE CONTROLLED BY DAMPER END POSITION SWITCHES.
- SMOKE DETECTORS IN THE SUPPLY AIR DUCTWORK SHALL STOP THE SUPPLY FAN AND INITIATE A SMOKE ALARM IF SMOKE IS DETECTED AT EITHER LOCATION. RESTARTING THE SUPPLY FAN SHALL REQUIRE MANUAL RESET AT THE SMOKE DETECTOR.

**DDC SETPOINTS:**

- THE CONTROL SYSTEM SETPOINTS AND DEADBANDS SHALL BE ADJUSTABLE AND SHALL BE SET AS:

ROOM	SETPOINT COOLING/HEATING	DEADBAND COOLING/HEATING
CAB	73°F/73°F	-2°F/+2°F
REMAINING SPACES	75°F/75°F	-2°F/+2°F

INPUT - OUTPUT SUMMARY												
POINT DESCRIPTION	INPUTS						OUTPUTS					
	ANALOG			DIGITAL			ANALOG			DIGITAL		
	HUMIDITY	TEMPERATURE	DUCT STATIC PRESSURE	DIFFERENTIAL PRESSURE	AUXILIARY CONTACT	DIFFERENTIAL PRESSURE SW	CURRENT RELAY	END POSITION SWITCH	0-10 VOLT CONTROL	POSITION ADJUSTMENT	CONTROL RELAY(S)	STATUS
AHU-T1/HP-T1												
AHU-T1B/HP-T1B												
AHU-T2/HP-T2												
AHU-T3/HP-T3												
AHU-T4/HP-T4												
AHU-T4B/HP-T4B												
SPACE	X	X										
SUPPLY AIR		X										
FILTER												
SUPPLY FAN							X				X	
CONDENSING UNIT STAGES											X	
REVERSING VALVE											X	
SUPPLEMENTAL HEAT STAGES											X	
OUTSIDE AIR		X										
COMMON RETURN AIR		X										
COMMON MIXED AIR		X										
SMOKE DETECTORS						X						
EXISTING EXHAUST FAN						X					X	
MOTORIZED ISOLATION DAMPER						X		X	X			
AUXILIARY HEAT						X					X	

INPUT - OUTPUT SUMMARY												
POINT DESCRIPTION	INPUTS						OUTPUTS					
	ANALOG			DIGITAL			ANALOG			DIGITAL		
	TEMPERATURE	DUCT STATIC PRESSURE	DIFFERENTIAL PRESSURE	AUXILIARY CONTACT	DIFFERENTIAL PRESSURE SW	CURRENT RELAY	0-10 VOLT CONTROL	POSITION ADJUSTMENT	CONTROL RELAY(S)			
FIRE ALARM												
TOWER GENERAL ALARM					X							
BASE BUILDING GENERAL ALARM					X							
GENERAL TROUBLE					X							
GENERAL SUPERVISORY					X							



SCALES SHOWN FOR 22" X 34" SHEET. ADJUST SCALES FOR OTHER SIZES.		PAGE		OF	
					
DEPARTMENT OF TRANSPORTATION FEDERAL AVIATION ADMINISTRATION					
FORT LAUDERDALE AIRPORT TRAFFIC CONTROL TOWER MAJOR IMPROVEMENTS MECHANICAL SEQUENCE OF OPERATION AND SYSTEM POINT LIST					
FT LAUDERDALE (INTERNATIONAL) FL					
REV	APPROVED DATE	DESCRIPTION	JCN	REDLINE DATE	APVD
REVIEWED BY		SUBMITTED BY		APPROVED BY	
DESIGNED		ISSUED BY		APPROVER'S TITLE - MANAGER	
DRAWN		ATLANTA TERMINAL ENGINEERING CENTER		DATE JAN 31, 2020 JCN 1508912	
CHECKED				DRAWING NO. FLL-D-ATCT-M801	
WILEY WILSON 5901 Peachtree Dunwoody Rd. Bldg. C, Ste 515 Atlanta, Georgia 30328-6055 678.320.1888 wileywilson.com WW JOB NUMBER: 219075.00					

NOTES

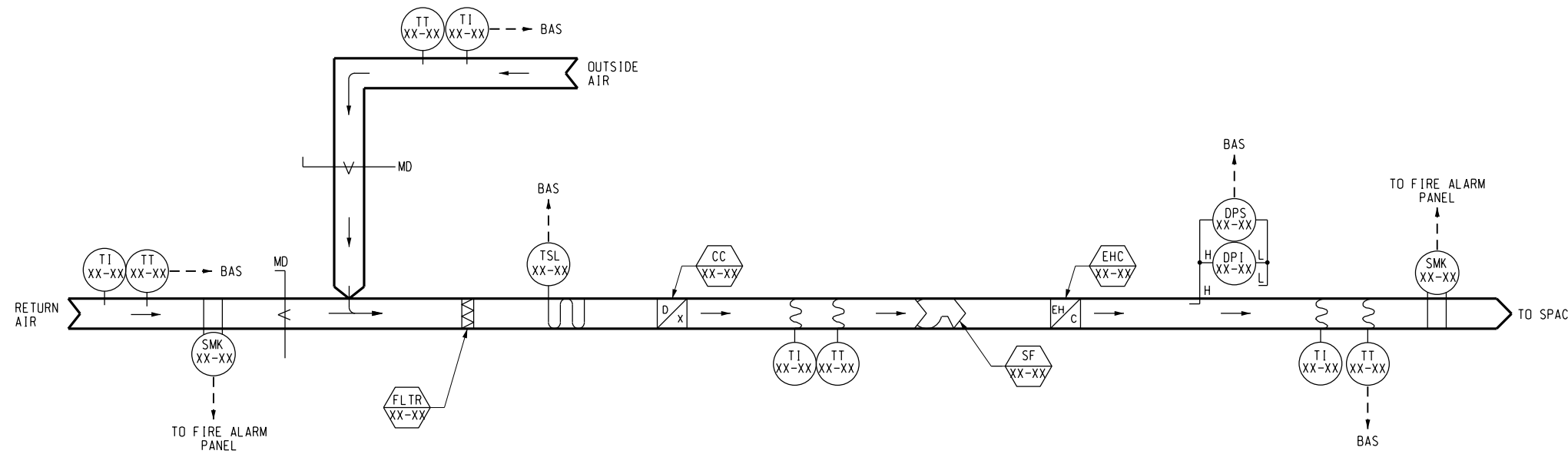
1. SEE DRAWING TRACO-M000 FOR HVAC LEGEND AND GENERAL NOTES.
2. THE SMOKE DETECTOR AND FIRE ALARM CONTROL MODULES SHALL BE FURNISHED AND INSTALLED BY FIRE ALARM CONTRACTOR.
3. INSTRUMENT NUMBER ASSIGNMENTS ARE OMITTED WHEN DIAGRAMS APPLY TO MULTIPLE SYSTEMS/ EQUIPMENT. CONTRACTOR SHALL ASSIGN THEM.



1 CONTROL SYSTEM DIAGRAM - FCU-T2 AND FCU-T3  
M801 NOT TO SCALE

SCALES SHOWN FOR 22" X 34" SHEET. ADJUST SCALES FOR OTHER SIZES.		PAGE	OF
			
			
5901 Peachtree Dunwoody Rd. Bldg. C, Ste 515 Atlanta, Georgia 30328-6055 678.320.1888 wileywilson.com WW JOB NUMBER: 219075.00			
REV	APPROVED DATE	DESCRIPTION	JCN
DEPARTMENT OF TRANSPORTATION FEDERAL AVIATION ADMINISTRATION FORT LAUDERDALE AIRPORT TRAFFIC CONTROL TOWER MAJOR IMPROVEMENTS MECHANICAL CONTROL SYSTEM DIAGRAM FCU-T2 AND FCU-T3 FT LAUDERDALE (INTERNATIONAL) FL			
REVIEWED BY	SUBMITTED BY	APPROVED BY	
DESIGNED	JJS	SUBMITTER'S TITLE - CIVIL ENGINEER	APPROVER'S TITLE - MANAGER
DRAWN	CRK	ISSUED BY	DATE JAN 31, 2020 JCN 1508912
CHECKED	JJS	ATLANTA TERMINAL ENGINEERING CENTER	DRAWING NO. FLL-D-ATCT-M802

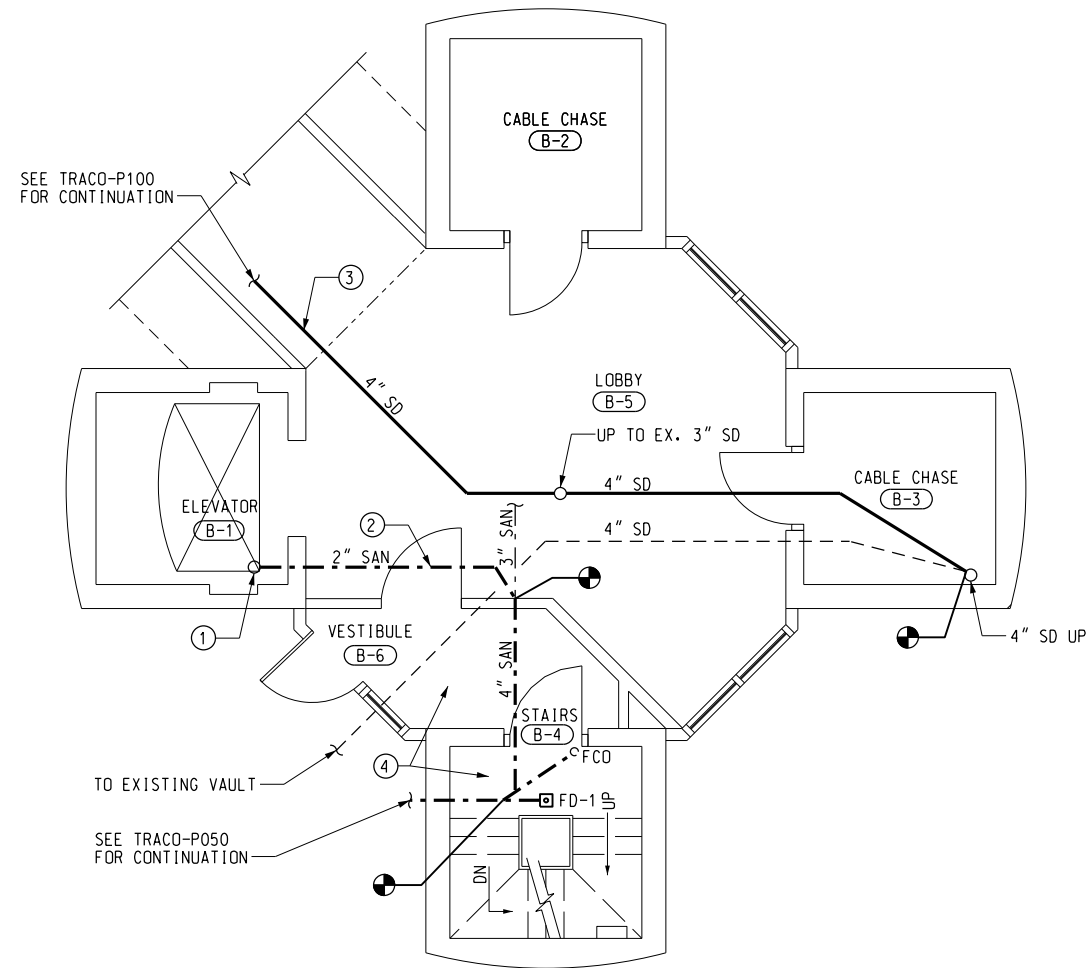

**1** GROUND LEVEL PLUMBING PLAN  
 P400 SCALE: 1/4" = 1' - 0"

**NOTES**

- ① CONNECT EXISTING SUMP PUMP TO NEW SEWER LINE. INCLUDE PIPE UNIONS THAT CAN BE REMOVED DURING PUMP MAINTENANCE.
- ② PERFORM REPAIR ON THIS LINE UP TO MAIN LINE CONNECTION. REPAIR OF REST OF LINE MUST BE PERFORMED IN STAGES TO ALLOW TOWER TO REMAIN IN OPERATION.
- ③ STORM DRAINS SHALL BE REPLACED PIECEMEAL TO ALLOW TOWER TO REMAIN IN OPERATION.
- ④ ALL WORK IN THIS AREA MUST ALLOW EGRESS PATH TO REMAIN IN OPERATION.

**GENERAL**

- A. NEW WORK IS SHOWN AS HEAVY LINE ON PLANS AND EXISTING WORK SHOWN AS LIGHT DASHED LINE.
- B. SEE TRACO-P000 FOR GENERAL NOTES AND SYMBOLS. SEE TOWB-G010 AND TOWB-G011 FOR ABBREVIATIONS.
- C. PIPE TO BE OF MATERIALS DESCRIBED IN AND SHALL BE INSTALLED PER SPECIFICATIONS.

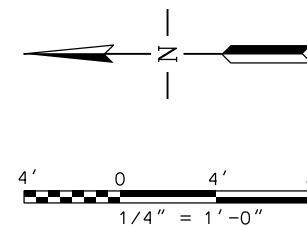

SCALES SHOWN FOR 22" X 34" SHEET. ADJUST SCALES FOR OTHER SIZES.				PAGE	OF
REV	APPROVED DATE	DESCRIPTION	JCN	REDLINE DATE	APVD
DEPARTMENT OF TRANSPORTATION <b>FEDERAL AVIATION ADMINISTRATION</b>					
<b>FORT LAUDERDALE AIRPORT TRAFFIC CONTROL TOWER            MAJOR IMPROVEMENTS            PLUMBING            GROUND LEVEL PLAN - NEW WORK</b>					
FT LAUDERDALE			(INTERNATIONAL)		FL
REVIEWED BY	SUBMITTED BY		APPROVED BY		
	SUBMITTER'S TITLE - CIVIL ENGINEER		APPROVER'S TITLE - MANAGER		
DESIGNED	JJS	ISSUED BY	DATE	JAN 31, 2020	JCN 1508912
DRAWN	CRK	ATLANTA TERMINAL ENGINEERING CENTER	DRAWING NO	FLL-D-ATCT-P400	
CHECKED	JJS				REV
WW JOB NUMBER: 219075.00					

**GENERAL NOTES**

- A. NEW WORK IS SHOWN AS HEAVY LINE ON PLANS AND EXISTING WORK SHOWN IS LIGHT SOLID LINE.
- B. SEE DRAWING TRACO-E000 AND TRACO-E001 FOR ELECTRICAL LEGEND, GENERAL NOTES AND SPECIAL NOTES.
- C. ALL EXTERIOR BOXES, HANGERS, MOUNTING SUPPORTS AND HARDWARE SHALL BE STAINLESS STEEL TYPE MATERIAL.

**KEY NOTES**

- ① PROVIDE NEW LED EXIT SIGN WITH 90-MINUTE BATTERY BACKUP. CONNECT NEW EXIT SIGN TO EXISTING CIRCUIT SERVED BY PANEL #9.

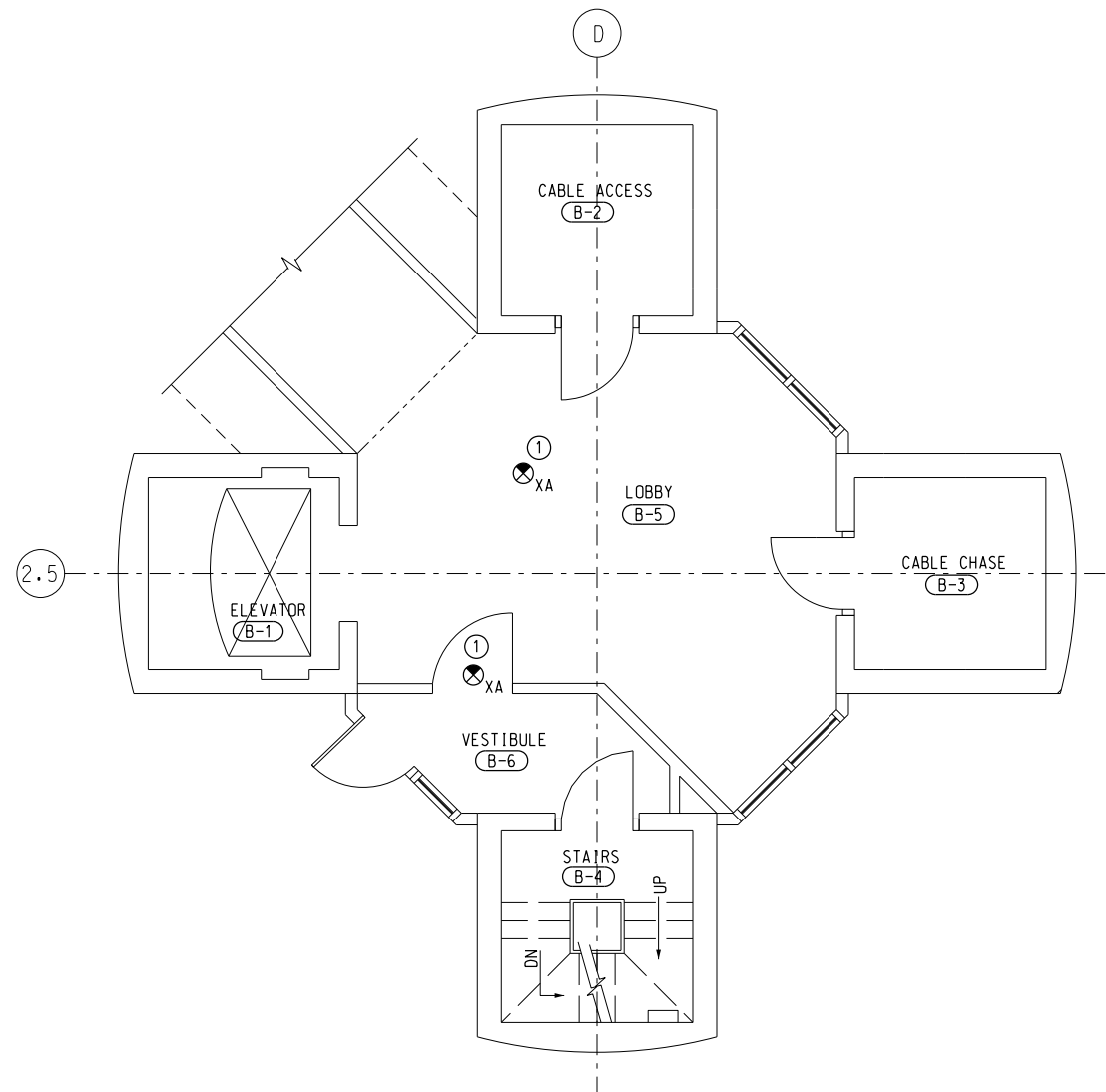

① **GROUND LEVEL POWER PLAN - NEW WORK**  
 E120 SCALE: 1/4" = 1'-0"

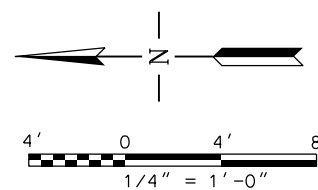

SCALES SHOWN FOR 22" X 34" SHEET. ADJUST SCALES FOR OTHER SIZES.				PAGE	OF
REV	APPROVED DATE	DESCRIPTION	JCN	REDLINE DATE	APVD
DEPARTMENT OF TRANSPORTATION <b>FEDERAL AVIATION ADMINISTRATION</b>					
<b>FORT LAUDERDALE AIRPORT TRAFFIC CONTROL TOWER                  MAJOR IMPROVEMENTS                  ELECTRICAL                  GROUND LEVEL POWER PLAN - NEW WORK</b>					
FT LAUDERDALE (INTERNATIONAL)				FL	
REVIEWED BY	SUBMITTED BY	APPROVED BY			
		SUBMITTER'S TITLE - CIVIL ENGINEER		APPROVER'S TITLE - MANAGER	
DESIGNED	JMC	ISSUED BY		DATE	JCN
DRAWN	CRK	ATLANTA TERMINAL ENGINEERING CENTER		JAN 31, 2020	1508912
CHECKED	MAK	DRAWING NO		FLL-D-ATCT-E120	
WILEY WILSON 5901 Peachtree Dunwoody Rd. Bldg. C, Ste 515 Atlanta, Georgia 30328-6055 678.320.1888 wileywilson.com WW JOB NUMBER: 219075.00					



# GENERAL NOTES

- A. NEW WORK IS SHOWN AS HEAVY LINE ON PLANS AND EXISTING WORK SHOWN IS LIGHT SOLID LINE.
- B. SEE DRAWING TRACO-E000 AND TRACO-E001 FOR ELECTRICAL LEGEND, GENERAL NOTES AND SPECIAL NOTES.
- C. ALL EXTERIOR BOXES, HANGERS, MOUNTING SUPPORTS AND HARDWARE SHALL BE STAINLESS STEEL TYPE MATERIAL.

# KEY NOTES

- ① NEW DDC CONTROL PANEL. CONNECT TO EXISTING CIRCUIT. CONTRACTOR SHALL FIELD VERIFY CIRCUIT PRIOR TO INSTALLATION.
- ② NEW MECHANICAL UNIT AHU-T4B. CONTRACTOR SHALL PROVIDE 60A NEMA 1, 208V 2-POLE NON-FUSED DISCONNECT. COORDINATE INSTALLATION WITH OVERHEAD EQUIPMENT TO COMPLY WITH REQUIRED NEC CLEARANCES. REPLACE 100A 3-POLE SPARE BREAKER IN PANEL ELPT WITH NEW 60A, 2-POLE BREAKER. PROVIDE NEW CONDUCTOR IN EMT CONDUIT TO PANEL ELPT WITH 3-#6AWG, #8G IN 1" C.
- ③ NEW MECHANICAL UNIT HP-T4B. CONTRACTOR SHALL PROVIDE 30A NEMA 4X, 208V 3-POLE FUSED DISCONNECT MOUNTED TO WALL. PROVIDE STAINLESS STEEL MOUNTING HARDWARE AND SUPPORTS. PROVIDE NEW 30A, 3-POLE BREAKER IN PANEL NLPTA. PROVIDE NEW CIRCUIT TO PANEL WITH 4-#10AWG, #10G IN 3/4" C. FOR EXTERIOR, PROVIDE PVC COATED RIGID CONDUIT TO DISCONNECT SWITCH, AND LFMC CONDUIT TO UNIT. INSTALLATION SHALL COMPLY WITH REQUIRED NEC CLEARANCES.
- ④ PROVIDE NEW LED EXIT SIGN WITH 90-MINUTE BATTERY BACKUP. CONNECT NEW EXIT SIGN TO EXISTING CIRCUIT SERVED BY PANEL NLPT.
- ⑤ PROVIDE NEW EMERGENCY LIGHT FIXTURE. CONNECT NEW FIXTURE TO EXISTING CIRCUIT SERVED BY PANEL NLPT.
- ⑥ CONNECT NEW AHU-T4 TO EXISTING CIRCUIT SERVED BY PANEL NLPTA. EXTEND WIRE AND CONDUIT AS REQUIRED FOR CONNECTION. CONTRACTOR SHALL PROVIDE 60A NEMA 1, 208, 2-POLE, NON-FUSED DISCONNECT. COORDINATE INSTALLATION WITH OVERHEAD EQUIPMENT TO COMPLY WITH REQUIRED NEC CLEARANCES.
- ⑦ CONNECT NEW HP-T4 TO EXISTING CIRCUIT SERVED BY PANEL NLPTA. EXTEND WIRE AND CONDUIT AS REQUIRED. CONTRACTOR SHALL PROVIDE 30A NEMA 4X, 208V 3-POLE FUSED DISCONNECT MOUNTED TO WALL. PROVIDE STAINLESS STEEL MOUNTING HARDWARE AND SUPPORTS. FOR EXTERIOR, PROVIDE PVC COATED RIGID CONDUIT TO DISCONNECT SWITCH, AND LFMC CONDUIT TO UNIT. INSTALLATION SHALL COMPLY WITH REQUIRED NEC CLEARANCES.

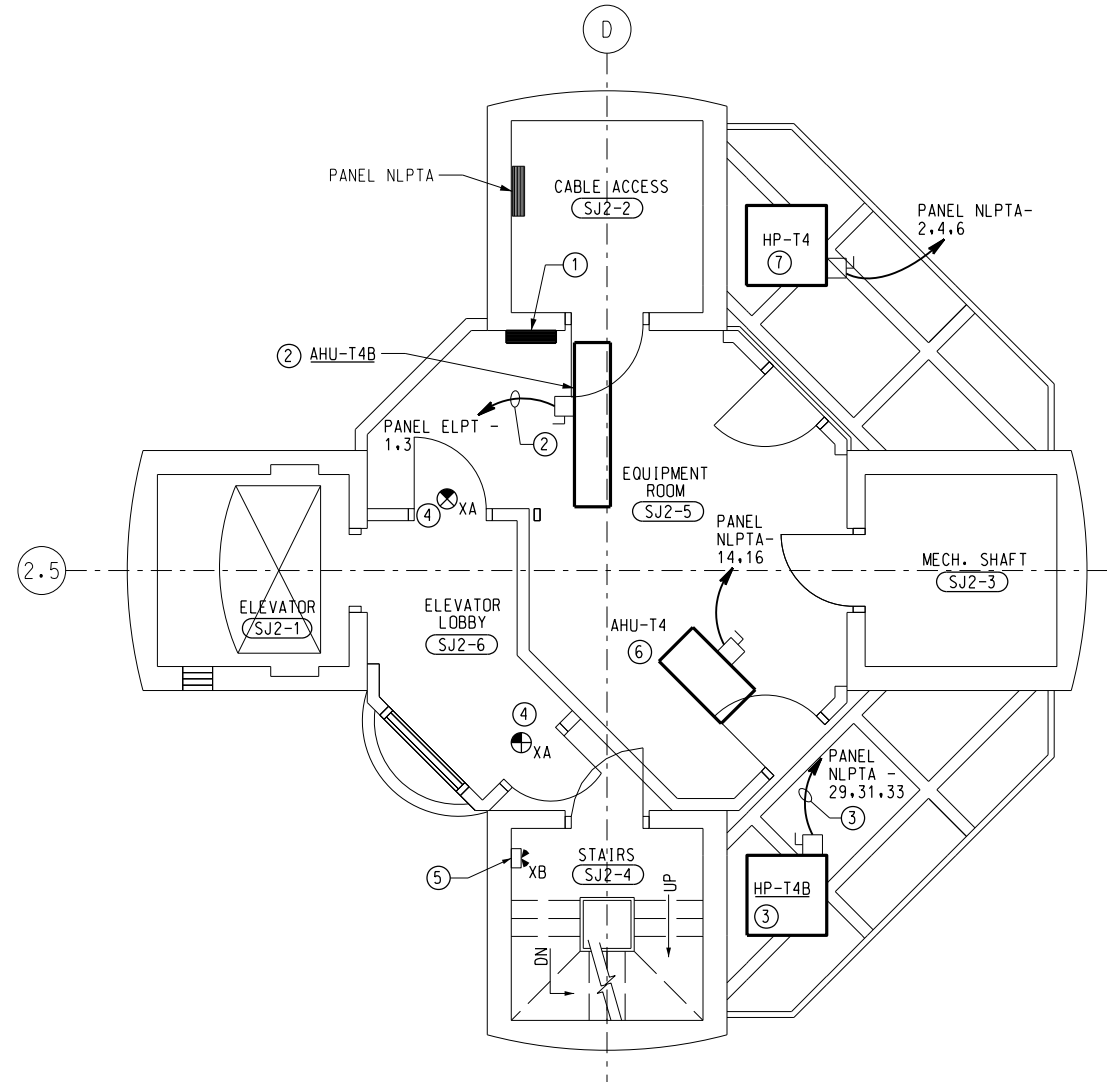

① SUBJUNCTION LEVEL TWO POWER PLAN - NEW WORK  
 E121 SCALE: 1/4" = 1'-0"

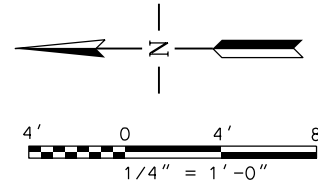

SCALES SHOWN FOR 22" X 34" SHEET. ADJUST SCALES FOR OTHER SIZES.		PAGE	OF
DEPARTMENT OF TRANSPORTATION FEDERAL AVIATION ADMINISTRATION			
FORT LAUDERDALE AIRPORT TRAFFIC CONTROL TOWER MAJOR IMPROVEMENTS ELECTRICAL SUBJUNCTION LEVEL 2 POWER PLAN - NEW WORK			
FT LAUDERDALE (INTERNATIONAL)		FL	
REV	APPROVED DATE	DESCRIPTION	JCN REDLINE DATE
REVIEWED BY	SUBMITTED BY	APPROVED BY	
DESIGNED	JMC	ISSUED BY	DATE
DRAWN	CRK	ATLANTA TERMINAL ENGINEERING CENTER	JAN 31, 2020
CHECKED	MAK		JCN 1508912
			DRAWING NO
			FLL-D-ATCT-E121
			REV
WILEY WILSON 5901 Peachtree Dunwoody Rd. Bldg. C, Ste 515 Atlanta, Georgia 30328-6055 678.320.1888 wileywilson.com WW JOB NUMBER: 219075.00			

**GENERAL NOTES**

- A. NEW WORK IS SHOWN AS HEAVY LINE ON PLANS AND EXISTING WORK SHOWN IS LIGHT SOLID LINE.
- B. SEE DRAWING TRACO-E000 AND TRACO-E001 FOR ELECTRICAL LEGEND, GENERAL NOTES AND SPECIAL NOTES.
- C. ALL EXTERIOR BOXES, HANGERS, MOUNTING SUPPORTS AND HARDWARE SHALL BE STAINLESS STEEL TYPE MATERIAL.

**KEY NOTES**

- ① EXISTING MECHANICAL EQUIPMENT TO REMAIN.
- ② NEW MECHANICAL UNIT AHU-T1B. CONTRACTOR SHALL PROVIDE 60A NEMA 1, 208V 2-POLE NON-FUSED DISCONNECT. COORDINATE INSTALLATION WITH OVERHEAD EQUIPMENT TO COMPLY WITH REQUIRED NEC CLEARANCES. PROVIDE NEW 60A, 2-POLE BREAKER IN PANEL NLPTA. PROVIDE NEW CIRCUIT TO PANEL NLPTA WITH 3-#6AWG, #8G IN 1" C.
- ③ NEW MECHANICAL UNIT HP-T1B. CONTRACTOR SHALL PROVIDE 60A NEMA 4X, 208V 3-POLE FUSED DISCONNECT MOUNTED TO WALL. PROVIDE STAINLESS STEEL MOUNTING HARDWARE AND SUPPORTS. PROVIDE NEW 35A, 3-POLE BREAKER IN PANEL NLPTA. PROVIDE NEW CIRCUIT TO PANEL WITH 4-#10AWG, #10G IN 3/4" C. FOR EXTERIOR, PROVIDE PVC COATED RIGID CONDUIT TO DISCONNECT SWITCH, AND LFMC CONDUIT TO UNIT. INSTALLATION SHALL COMPLY WITH REQUIRED NEC CLEARANCES.
- ④ PROVIDE NEW LED EXIT SIGN WITH 90-MINUTE BATTERY BACKUP. CONNECT NEW EXIT SIGN TO EXISTING EMERGENCY CIRCUIT.
- ⑤ NEW DDC CONTROL PANEL, CONNECT TO EXISTING CIRCUIT. CONTRACTOR SHALL FIELD VERIFY CIRCUIT PRIOR TO INSTALLATION.
- ⑥ CONNECT NEW AHU-T1 TO EXISTING CIRCUIT SERVED BY PANEL NLPT. EXTEND WIRE AND CONDUIT AS REQUIRED FOR CONNECTION. CONTRACTOR SHALL PROVIDE 60A NEMA 1, 208, 2-POLE, NON-FUSED DISCONNECT. COORDINATE INSTALLATION WITH OVERHEAD EQUIPMENT TO COMPLY WITH REQUIRED NEC CLEARANCES.
- ⑦ CONNECT NEW HP-T1 TO EXISTING CIRCUIT SERVED BY PANEL NLPTA. EXTEND WIRE AND CONDUIT AS REQUIRED. CONTRACTOR SHALL PROVIDE 30A NEMA 4X, 208V 3-POLE FUSED DISCONNECT MOUNTED TO WALL. PROVIDE STAINLESS STEEL MOUNTING HARDWARE AND SUPPORTS.

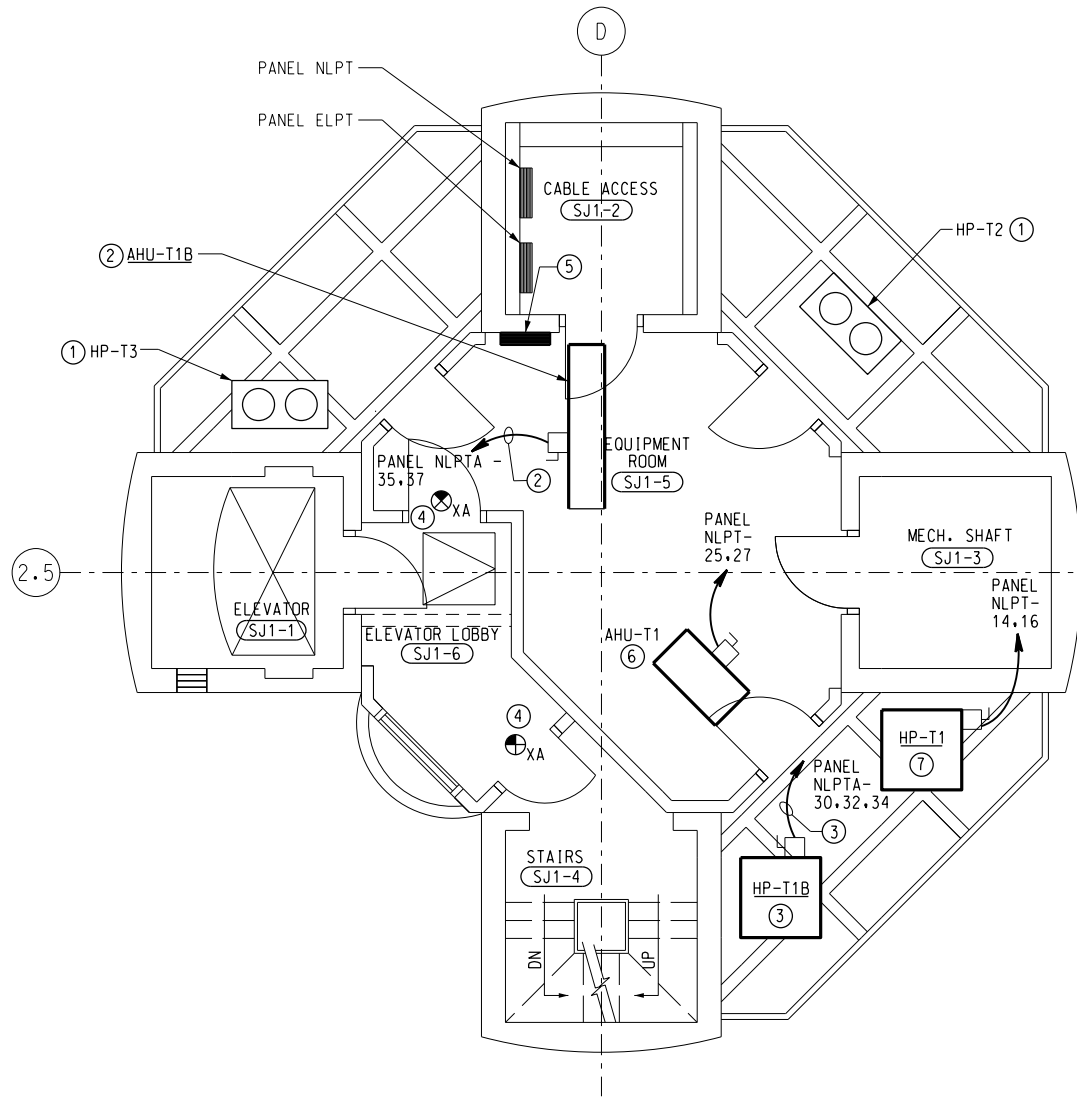

**1 SUBJUNCTION LEVEL 1 PLAN - NEW WORK**  
 E122 SCALE: 1/4" = 1'-0"

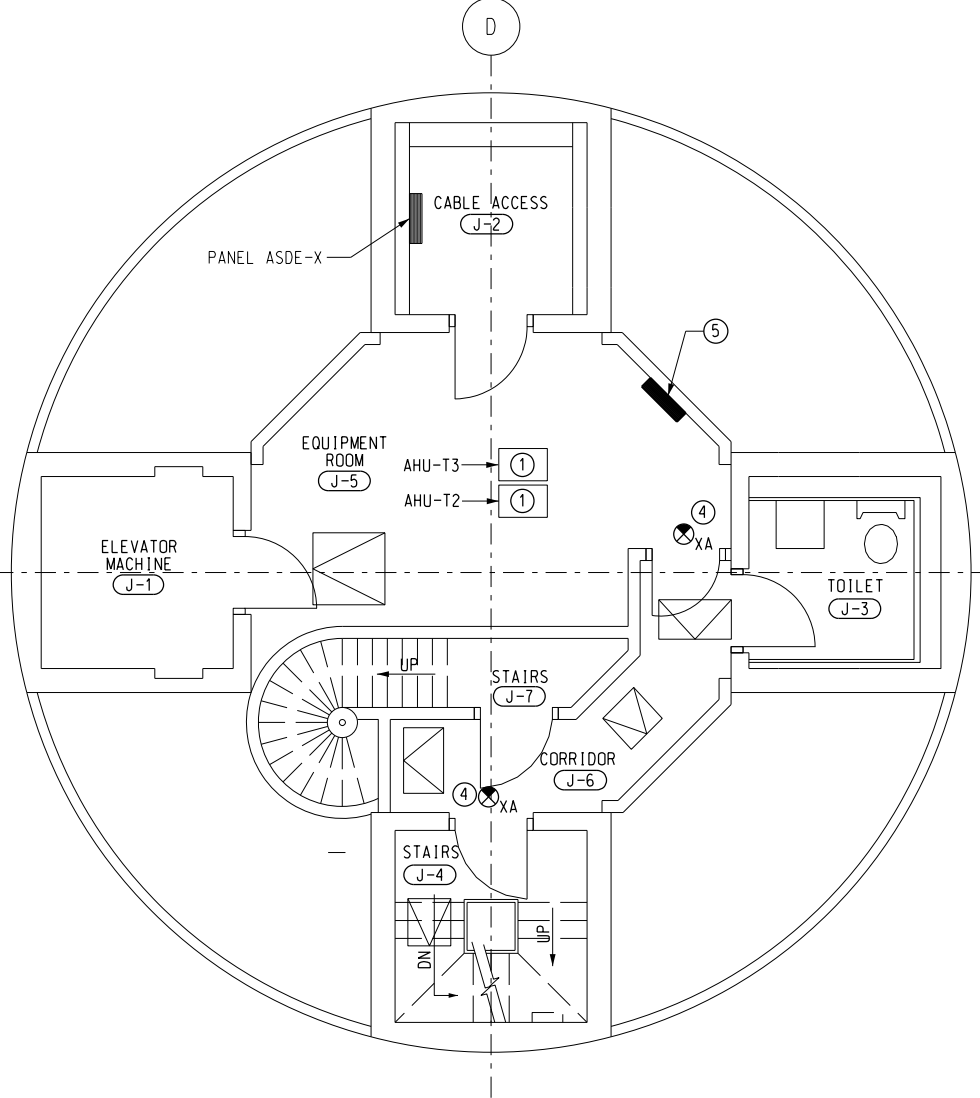

**2 JUNCTION LEVEL PLAN - NEW WORK**  
 E122 SCALE: 1/4" = 1'-0"

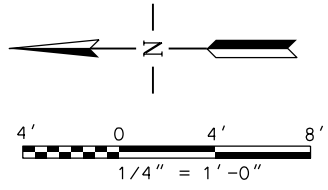

SCALES SHOWN FOR 22" X 34" SHEET. ADJUST SCALES FOR OTHER SIZES.		PAGE		OF			
 <b>WileyWilson</b> 5901 Peachtree Dunwoody Rd. Bldg. C, Ste 515 Atlanta, Georgia 30328-6055 678.320.1888 wileywilson.com WW JOB NUMBER: 219075.00		REV	APPROVED DATE	DESCRIPTION	JCN	REDLINE DATE	APVD
		DEPARTMENT OF TRANSPORTATION <b>FEDERAL AVIATION ADMINISTRATION</b>  FORT LAUDERDALE AIRPORT TRAFFIC CONTROL TOWER MAJOR IMPROVEMENTS ELECTRICAL <b>SUBJUNCTION LEVEL 1 AND JUNCTION LEVEL - NEW WORK</b> FT LAUDERDALE (INTERNATIONAL) FL					
REVIEWED BY	SUBMITTED BY	APPROVED BY					
DESIGNED BY	MDS	SUBMITTER'S TITLE - CIVIL ENGINEER		APPROVER'S TITLE - MANAGER			
DRAWN BY	CRK	ISSUED BY		DATE JAN 31, 2020		JCN 1508912	
CHECKED BY	MDS	ATLANTA TERMINAL ENGINEERING CENTER		DRAWING NO		FLL-D-ATCT-E122	



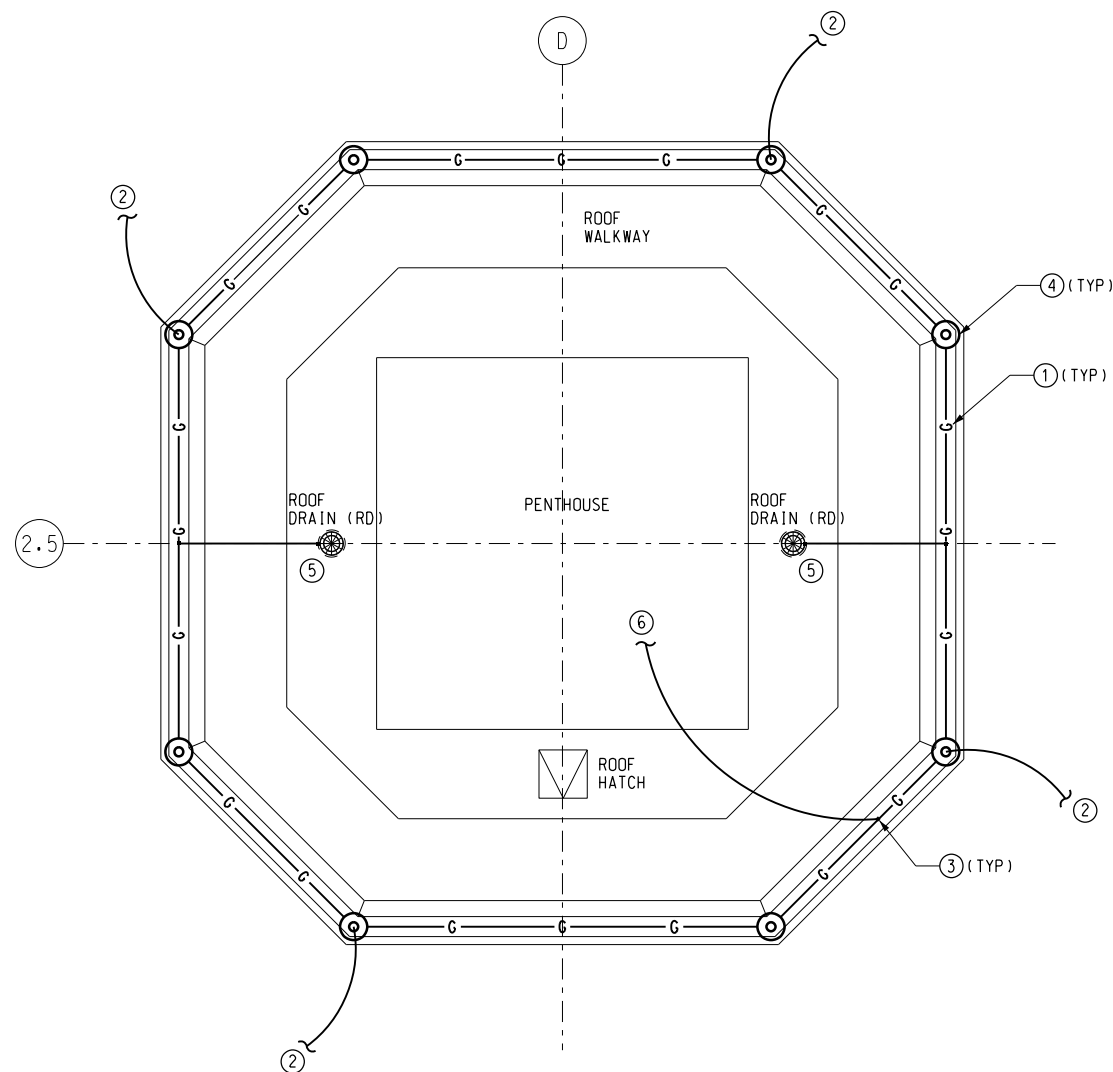

1 CAB ROOF PLAN - LIGHTNING PROTECTION  
 E160 SCALE: 1/4" = 1' - 0"

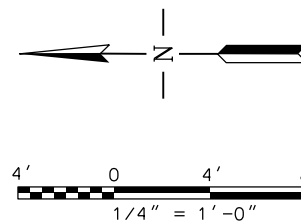

### GENERAL NOTES

- A. SEE DRAWING TRACO-E000 AND TRACO-E001 FOR ELECTRICAL LEGEND, GENERAL NOTES AND SPECIAL NOTES
- B. REMOVE EXISTING LIGHTNING PROTECTION ROOF CONDUCTOR AND ACCESORIES TO FACILITATE ROOF REPLACEMENT. ROOF CONDUCTORS AND BONDS TO BE REPLACED.
- C. ALL TOWER (ATCT) LIGHTING PROTECTION ROOF CONDUCTOR SHALL BE CLASS II MATERIAL. CONDUCTORS, AIR TERMINALS AND ALL OTHER ACCESSORIES SHALL BE MADE OF COPPER, EXCEPT WHERE DISSIMILAR METALS REQUIRE ALUMINUM. USE BI-METALLIC CONNECTORS AS NEEDED TO CONNECT COPPER AND ALUMINUM MATERIALS.
- D. DOWN CONDUCTOR TERMINATIONS TO THE EES SHALL BE EXOTHERMICALLY WELDED TO A 4/0 AWG COPPER CONDUCTOR PRIOR TO ENTERING THE GROUND AT NOT LESS THAN 18" ABOVE GRADE. THE 4/0 AWG COPPER CONDUCTOR SHALL BE BONDED DIRECTLY TO A GROUND ROD OR ELECTRODE CONDUCTOR IN THE EES (FAA-STD-019F, SECTION 4.3.5.1). DOWN CONDUCTOR CONDUIT SHALL END JUST ABOVE WELDING POINT. PROVIDE AN ACCESSIBLE JUNCTION BOX TO PROTECT WELD. BELOW WELD, BARE CONDUCTOR SHALL RUN INTO THE GROUND TO CONNECT TO COUNTERPOISE.
- E. SUPPORT ROOF CONDUCTOR AT A MIN OF EVERY 3' UTILIZING AN ADHESIVE CABLE CLAMP THOMPSON 186X (OR EQUAL).
- F. TEST AND CONFIRM THAT EXISTING EES RESISTANCE TO GROUND IS LESS THAN 10 OHMS (FAA-STD-019F, SECTION 4.4.3).
- G. COORDINATE LIGHTNING PROTECTION ATTACHMENT POINT WATERPROOFING WITH ROOF INSTALLATION SUCH THAT FLASHING IS NOT DEFEATED.
- H. CONSULT WITH A LIGHTNING PROTECTION PROFESSIONAL TO PROVIDE TEMPORARY LIGHTNING PROTECTION PROVISIONS DURING CONSTRUCTION.

### KEY NOTES

- ① CLASS II ROOF CONDUCTOR. THOMPSON 506T OR APPROVED EQUAL.
- ② CLASS II DOWN CONDUCTOR. THOMPSON 506T OR APPROVED EQUAL. BOND DOWN CONDUCTOR TO ROOF CONDUCTOR USING MECHANICAL TERMINATIONS PER DETAIL 1, SHEET TRACO-E601. DOWN CONDUCTORS SHALL EXTEND TO GROUND COUNTERPOISE WITHIN PVC CONDUIT. DOWN CONDUCTORS SHALL FOLLOW THE MOST DIRECT DOWNWARD COURSE, WHILE MAIN AND BONDING CONDUCTORS MUST MAINTAIN A DOWNWARD OR HORIZONTAL COURSE WITH NO BEND LESS THAN 90 DEGREES OR BEND RADIUS LESS THAN 8". ROOF AND DOWN CONDUCTORS SHALL BE FASTENED WITH CABLE HOLDER THOMPSON 186X OR APPROVED EQUAL, AT INTERVALS NOT MORE THAN 3'-0" AND SHALL BE THE SAME MATERIAL AS THE CONDUCTOR. BONDING DEVICES, CONDUCTOR SPLICES, CONDUCTOR ATTACHMENTS, AND CONNECTORS SHALL BE SUITABLE FOR USE WITH THE INSTALLED CONDUCTOR. WHERE DOWN CONDUCTOR ENCOUNTER CANOPY, ROUTE DOWN CONDUCTOR THROUGH 1" PVC SLEEVE. BOND CANOPY TO DOWN CONDUCTORS USING EXOTHERMIC WELD. BOND ALL METALLIC OBJECTS WITHIN 6' OF DOWN CONDUCTORS TO DOWN OR ROOF GROUNDING LOOP TO THE LIGHTNING PROTECTION SYSTEM WITH EXOTHERMIC WELD.
- ③ BONDING CONNECTION. SEE BONDING AND SPLICING DETAIL 1, SHEET TRACO-E601.
- ④ 24" BLUNT-TIPPED AIR TERMINAL. TERMINAL SHALL BE MOUNTED TO PARAPET WALL PER DETAIL 2, SHEET TRACO-E601.
- ⑤ BOND ROOF CONDUCTOR TO ALL ROOF DRAINS PER DETAIL 1, SHEET TRACO-E600.
- ⑥ BONDING JUMPER TO EXISTING ANTENNA EQUIPMENT ON PENTHOUSE. UTILIZE CONDUIT GROUND CLAMP PER DETAIL 5, SHEET TRACO-E600.

SCALES SHOWN FOR 22" X 34" SHEET. ADJUST SCALES FOR OTHER SIZES.				PAGE	OF
<b>DEPARTMENT OF TRANSPORTATION            FEDERAL AVIATION ADMINISTRATION</b>					
<b>FORT LAUDERDALE AIRPORT TRAFFIC CONTROL TOWER            MAJOR IMPROVEMENTS            ELECTRICAL            CAB LEVEL ROOF PLAN - LIGHTNING PROTECTION</b>					
FT LAUDERDALE (INTERNATIONAL) FL					
REV	APPROVED DATE	DESCRIPTION	JCN	REDLINE DATE	APVD
REVIEWED BY		SUBMITTED BY		APPROVED BY	
DESIGNED BY		SUBMITTER'S TITLE - CIVIL ENGINEER		APPROVER'S TITLE - MANAGER	
	JMC			DATE JAN 31, 2020 JCN 1508912	
DRAWN BY		ISSUED BY		DRAWING NO	
	CRK	ATLANTA TERMINAL ENGINEERING CENTER		FLL-D-ATCT-E160	
CHECKED BY		MAK		REV	

**Wiley|Wilson**  
 5901 Peachtree Dunwoody Rd.  
 Bldg. C, Ste 515  
 Atlanta, Georgia 30328-6055  
 678.320.1888  
 wileywilson.com

WW JOB NUMBER: 219075.00

**GENERAL NOTES:**

- A. CIRCUIT ASSIGNMENTS TO NEW AND EXISTING LOADS ARE USED FOR REFERENCE ONLY. ACTUAL CIRCUIT ASSIGNMENT OF EXISTING LOADS AND AVAILABILITY OF ACTUAL SPARE CIRCUIT BREAKERS AND SPACES AVAILABLE IN EXISTING PANELS SHALL BE FIELD VERIFIED PRIOR TO THE BEGINNING OF NEW CONSTRUCTION.
- B. VERIFY ALL CIRCUITS ON EXISTING PANELS. ADJUST CIRCUITING AS REQUIRED TO MEET DESIGN INTENT ON DRAWINGS. FOR ANY VACATED CIRCUITS, REMOVE CONDUIT AND WIRING BACK TO PANEL, TURN BREAKER OFF, AND MARK BREAKER AS 'SPARE'.
- C. PROVIDE NEW TYPED PANELBOARD DIRECTORY TO INDICATE ACTUAL CIRCUITS USED, UPON COMPLETION OF WORK.
- D. CONTRACTOR SHALL REUSE EXISTING SPARE CIRCUIT BREAKERS OR EXISTING BREAKERS THAT HAVE BECOME AVAILABLE FOLLOWING DEMOLITION. PROVIDE NEW BREAKERS AS REQUIRED WITH TYPE, VOLTAGE RATING, AND AIC RATING MATCHING THE EXISTING BREAKER.

**KEY NOTES:**

- ① REPLACE EXISTING 100A 3-POLE SPARE BREAKER WITH NEW 60A 2-POLE BREAKER. TO BE REPURPOSED FOR AHU-T4B.

PANEL SCHEDULE (EXISTING)																																																																																			
DESIGNATION: NLPT FED FROM: MDPN LOCATION: CABLE ACCESS SJ1-2						PANEL CHARACTERISTICS MAIN: 225 A MCB 3 PHASE BUS AMPERAGE: 225 AMPS 4 WIRE + GROUND VOLTAGE: 120/208 VOLTS 100% NEUTRAL AIC: EXIST. MOUNTING: SURFACE																																																																													
Branch Circuit Load Description	kVA Loads			Trip / Poles	Ckt. No.	Phase	Ckt. No.	Trip / Poles	kVA Loads			Branch Circuit Load Description																																																																							
	A	B	C						A	B	C																																																																								
ELECTRIC HEAT				15/3	1	A	2					SPACE																																																																							
					3	B	4	20/1				ASDE DDS																																																																							
					5	C	6	20/1				CHEMICAL FEED																																																																							
RWSL				20/2	7	A	8	20/2				SPARE																																																																							
					9	B	10																																																																												
EF-1				20/1	11	C	12	20/1				SPARE																																																																							
RWSL TCCA				15/1	13	A	14	100/3				SPACE																																																																							
CENTRAL VAC CV-1				20/1	15	B	16																																																																												
EWH				20/1	17	C	18																																																																												
WASH DOWN PUMP				30/1	19	A	20	100/3				ELEVATOR MAIN TRANS																																																																							
ASOS A.C.V				20/1	21	B	22																																																																												
CABLE LIGHT				20/1	23	C	24																																																																												
AHU-T1	5.38			60/2	26	A	26	20/1				9TH FLR STAIRS & RECEPT																																																																							
		5.38			27	B	28	20/1				9TH FLR STAIRS & RECEPT																																																																							
CABLE CHASE LIGHT				20/1	29	C	30	20/1				CABLE CHASE RECEPT																																																																							
CABLE CHASE LIGHT				20/1	31	A	32	20/1				CABLE CHASE RECEPT																																																																							
BASE LEVEL LIGHT				20/1	33	B	34	20/1				CABLE CHASE RECEPT																																																																							
SUMP PUMP				20/1	35	C	36					SPACE																																																																							
TOWER RECPT				20/1	37	A	38	30/3				SPD																																																																							
TOWER RECPT				20/1	39	B	40																																																																												
CABLE LIGHT				20/1	41	C	42																																																																												
<table border="1" style="width: 100%; border-collapse: collapse;"> <tr> <td>5.38</td> <td>5.38</td> <td colspan="9" style="text-align: center;">&lt;&lt;PHASE SUB-TOTALS&gt;&gt;</td> </tr> <tr> <td colspan="3"></td> <td>Phase A</td> <td>Phase B</td> <td>Phase C</td> <td colspan="6"></td> </tr> <tr> <td colspan="3">PHASE TOTALS:</td> <td>5.38</td> <td>5.38</td> <td></td> <td colspan="6">kVA</td> </tr> </table>												5.38	5.38	<<PHASE SUB-TOTALS>>												Phase A	Phase B	Phase C							PHASE TOTALS:			5.38	5.38		kVA																																										
5.38	5.38	<<PHASE SUB-TOTALS>>																																																																																	
			Phase A	Phase B	Phase C																																																																														
PHASE TOTALS:			5.38	5.38		kVA																																																																													
<table border="1" style="width: 100%; border-collapse: collapse;"> <thead> <tr> <th colspan="3">LOAD SUMMARY (KVA)</th> <th colspan="3"></th> </tr> <tr> <th>LOAD TYPE</th> <th>CONNECTED</th> <th>DEMAND</th> <th colspan="3"></th> </tr> </thead> <tbody> <tr><td>Lighting</td><td></td><td></td><td colspan="3"></td></tr> <tr><td>Receptacles</td><td></td><td></td><td colspan="3"></td></tr> <tr><td>UPS</td><td></td><td></td><td colspan="3"></td></tr> <tr><td>Equipment: Continuous</td><td></td><td></td><td colspan="3"></td></tr> <tr><td>Equipment: Non-Continuous</td><td></td><td></td><td colspan="3"></td></tr> <tr><td>Kitchen</td><td></td><td></td><td colspan="3"></td></tr> <tr><td>Mechanical: Concurrent</td><td>10.76</td><td>8.61</td><td colspan="3"></td></tr> <tr><td>Mech: Non-Concurrent</td><td></td><td></td><td colspan="3"></td></tr> <tr><td>Supplemental AC</td><td></td><td></td><td colspan="3"></td></tr> <tr><td>TOTALS (kVA)</td><td>10.76</td><td>8.61</td><td colspan="3"></td></tr> </tbody> </table>												LOAD SUMMARY (KVA)						LOAD TYPE	CONNECTED	DEMAND				Lighting						Receptacles						UPS						Equipment: Continuous						Equipment: Non-Continuous						Kitchen						Mechanical: Concurrent	10.76	8.61				Mech: Non-Concurrent						Supplemental AC						TOTALS (kVA)	10.76	8.61			
LOAD SUMMARY (KVA)																																																																																			
LOAD TYPE	CONNECTED	DEMAND																																																																																	
Lighting																																																																																			
Receptacles																																																																																			
UPS																																																																																			
Equipment: Continuous																																																																																			
Equipment: Non-Continuous																																																																																			
Kitchen																																																																																			
Mechanical: Concurrent	10.76	8.61																																																																																	
Mech: Non-Concurrent																																																																																			
Supplemental AC																																																																																			
TOTALS (kVA)	10.76	8.61																																																																																	
<table border="1" style="width: 100%; border-collapse: collapse;"> <tr> <td colspan="3"></td> <td colspan="3" style="text-align: center;">PROVIDE THE FOLLOWING:</td> </tr> <tr><td colspan="3"></td><td colspan="3"></td></tr> <tr><td colspan="3"></td><td colspan="3"></td></tr> <tr><td colspan="3"></td><td colspan="3"></td></tr> <tr><td colspan="3"></td><td colspan="3"></td></tr> <tr><td colspan="3"></td><td colspan="3"></td></tr> <tr><td colspan="3"></td><td colspan="3"></td></tr> <tr><td colspan="3"></td><td colspan="3"></td></tr> <tr><td colspan="3"></td><td colspan="3"></td></tr> <tr><td colspan="3"></td><td colspan="3"></td></tr> <tr><td colspan="3"></td><td colspan="3"></td></tr> </table>															PROVIDE THE FOLLOWING:																																																																				
			PROVIDE THE FOLLOWING:																																																																																

PANEL SCHEDULE (EXISTING)																																																																																			
DESIGNATION: ELPT FED FROM: MDPE LOCATION: CABLE ACCESS SJ1-2						PANEL CHARACTERISTICS MAIN: 225 A MCB 3 PHASE BUS AMPERAGE: 225 AMPS 4 WIRE + GROUND VOLTAGE: 120/208 VOLTS 100% NEUTRAL AIC: EXIST. MOUNTING: SURFACE																																																																													
Branch Circuit Load Description	kVA Loads			Trip / Poles	Ckt. No.	Phase	Ckt. No.	Trip / Poles	kVA Loads			Branch Circuit Load Description																																																																							
	A	B	C						A	B	C																																																																								
AHU-T4B	5.38			60/2	1	A	2	35/3				AHU-T3																																																																							
		5.38			3	B	4																																																																												
SPACE					5	C	6																																																																												
HP-T2				70/3	7	A	8	70/3				HP-T3																																																																							
					9	B	10																																																																												
					11	C	12																																																																												
AHU-T2				35/3	13	A	14	20/1				RCPT SUP CONSL																																																																							
					15	B	16					SPACE																																																																							
					17	C	18	20/1				EXHAUST FAN EF-4																																																																							
NORTH DISPLAY				20/1	19	A	20	20/1				HEATER AHU-3																																																																							
SOUTH BRITE				20/1	21	B	22	20/1				HEATER AHU-3																																																																							
BCAD CCTV				20/1	23	C	24	20/1				9TH FLR A/COND																																																																							
CYPHERLOCK SYSTEM				20/1	25	A	26	20/1				10TH FLR A/COND																																																																							
FLOOR OUTLETS				20/1	27	B	28	20/1				ELEVATOR MECH RM RCPT																																																																							
OBSTRUCTION LIGHT				20/1	29	C	30	20/1				ELEVATOR LIGHTS																																																																							
CAB LIGHTS				20/1	31	A	32	20/1				CABLE ACCESS LIGHT																																																																							
CAB LIGHTS				20/1	33	B	34	20/1				STAIR LIGHTS																																																																							
CAB LIGHTS				20/1	35	C	36	20/1				CAB A/C PANEL																																																																							
TRAFFIC GUN LIGHT NORTH				20/1	37	A	38	20/1				9TH FLR LIGHTS																																																																							
TRAFFIC GUN LIGHT SOUTH				20/1	39	B	40	20/1				ELEVATOR MECH RM RCPT																																																																							
ELEVATOR SHAFT LIGHTS				20/1	41	C	42	20/1				FIRE DAMPER																																																																							
<table border="1" style="width: 100%; border-collapse: collapse;"> <tr> <td>5.38</td> <td>5.38</td> <td colspan="9" style="text-align: center;">&lt;&lt;PHASE SUB-TOTALS&gt;&gt;</td> </tr> <tr> <td colspan="3"></td> <td>Phase A</td> <td>Phase B</td> <td>Phase C</td> <td colspan="6"></td> </tr> <tr> <td colspan="3">PHASE TOTALS:</td> <td>5.38</td> <td>5.38</td> <td></td> <td colspan="6">kVA</td> </tr> </table>												5.38	5.38	<<PHASE SUB-TOTALS>>												Phase A	Phase B	Phase C							PHASE TOTALS:			5.38	5.38		kVA																																										
5.38	5.38	<<PHASE SUB-TOTALS>>																																																																																	
			Phase A	Phase B	Phase C																																																																														
PHASE TOTALS:			5.38	5.38		kVA																																																																													
<table border="1" style="width: 100%; border-collapse: collapse;"> <thead> <tr> <th colspan="3">LOAD SUMMARY (KVA)</th> <th colspan="3"></th> </tr> <tr> <th>LOAD TYPE</th> <th>CONNECTED</th> <th>DEMAND</th> <th colspan="3"></th> </tr> </thead> <tbody> <tr><td>Lighting</td><td></td><td></td><td colspan="3"></td></tr> <tr><td>Receptacles</td><td></td><td></td><td colspan="3"></td></tr> <tr><td>UPS</td><td></td><td></td><td colspan="3"></td></tr> <tr><td>Equipment: Continuous</td><td></td><td></td><td colspan="3"></td></tr> <tr><td>Equipment: Non-Continuous</td><td></td><td></td><td colspan="3"></td></tr> <tr><td>Kitchen</td><td></td><td></td><td colspan="3"></td></tr> <tr><td>Mechanical: Concurrent</td><td>10.76</td><td>8.61</td><td colspan="3"></td></tr> <tr><td>Mech: Non-Concurrent</td><td></td><td></td><td colspan="3"></td></tr> <tr><td>Supplemental AC</td><td></td><td></td><td colspan="3"></td></tr> <tr><td>TOTALS (kVA)</td><td>10.76</td><td>8.61</td><td colspan="3"></td></tr> </tbody> </table>												LOAD SUMMARY (KVA)						LOAD TYPE	CONNECTED	DEMAND				Lighting						Receptacles						UPS						Equipment: Continuous						Equipment: Non-Continuous						Kitchen						Mechanical: Concurrent	10.76	8.61				Mech: Non-Concurrent						Supplemental AC						TOTALS (kVA)	10.76	8.61			
LOAD SUMMARY (KVA)																																																																																			
LOAD TYPE	CONNECTED	DEMAND																																																																																	
Lighting																																																																																			
Receptacles																																																																																			
UPS																																																																																			
Equipment: Continuous																																																																																			
Equipment: Non-Continuous																																																																																			
Kitchen																																																																																			
Mechanical: Concurrent	10.76	8.61																																																																																	
Mech: Non-Concurrent																																																																																			
Supplemental AC																																																																																			
TOTALS (kVA)	10.76	8.61																																																																																	
<table border="1" style="width: 100%; border-collapse: collapse;"> <tr> <td colspan="3"></td> <td colspan="3" style="text-align: center;">PROVIDE THE FOLLOWING:</td> </tr> <tr><td colspan="3"></td><td colspan="3"></td></tr> <tr><td colspan="3"></td><td colspan="3"></td></tr> <tr><td colspan="3"></td><td colspan="3"></td></tr> <tr><td colspan="3"></td><td colspan="3"></td></tr> <tr><td colspan="3"></td><td colspan="3"></td></tr> <tr><td colspan="3"></td><td colspan="3"></td></tr> <tr><td colspan="3"></td><td colspan="3"></td></tr> <tr><td colspan="3"></td><td colspan="3"></td></tr> <tr><td colspan="3"></td><td colspan="3"></td></tr> <tr><td colspan="3"></td><td colspan="3"></td></tr> </table>															PROVIDE THE FOLLOWING:																																																																				
			PROVIDE THE FOLLOWING:																																																																																

SCALES SHOWN FOR 22" X 34" SHEET. ADJUST SCALES FOR OTHER SIZES.				PAGE	OF
					
REV	APPROVED DATE	DESCRIPTION	JCN	REDLINE DATE	APVD
DEPARTMENT OF TRANSPORTATION FEDERAL AVIATION ADMINISTRATION  FORT LAUDERDALE AIRPORT TRAFFIC CONTROL TOWER MAJOR IMPROVEMENTS ELECTRICAL PANEL SCHEDULES					
FT LAUDERDALE (INTERNATIONAL)			FL		
REVIEWED BY		SUBMITTED BY		APPROVED BY	
SUBMITTER'S TITLE - CIVIL ENGINEER			APPROVER'S TITLE - MANAGER		
DESIGNED JMC		ISSUED BY		DATE JAN 31, 2020 JCN 1508912	
DRAWN JMC		ATLANTA TERMINAL ENGINEERING CENTER		DRAWING NO	
CHECKED MRK				FLL-D-ATCT-E500	
WILEY WILSON 5901 Peachtree Dunwoody Rd. Bldg. C, Ste 515 Atlanta, Georgia 30328-6055 678.320.1888 wileywilson.com  WW JOB NUMBER: 219075.00					



**NOTES**

1. ALL INTERIOR WALLS, CEILINGS, FLOORS, DOORS AND OTHER FINISHED CONSTRUCTION THAT ARE DAMAGED OR ALTERED BY THE CONTRACTOR SHALL BE RESTORED TO ORIGINAL CONDITION.
2. PRIOR TO ANY FIRESTOPPING MATERIALS OR ASSEMBLY BEING INSTALLED, THE CONTRACTOR SHALL HAVE SUBMITTED TO THE FAA RESIDENT ENGINEER MSDS OF ALL MATERIALS INTENDED FOR USE. NO SUBSTITUTIONS SHALL BE PERMITTED WITHOUT THE WRITTEN PERMISSION OF THE RESIDENT ENGINEER. REFER TO SPECIFICATION SECTION 07840 FOR APPROVED FIRESTOPPING MATERIALS AND METHODS.
3. PROVIDE UL-LISTED ASSEMBLIES OR ENGINEERED SYSTEMS FOR ALL FIRE BARRIER AND FIRESTOPPING APPLICATIONS AT ALL REQUIRED LOCATIONS. FIRESTOPPING IS ALSO REQUIRED FOR ALL PENETRATIONS MADE BY THE CONTRACTOR FOR ALL DEMO AND NEW WORK. UL CLASSIFICATION PRODUCT DATA SHEET OR MANUFACTURER'S ENGINEERED SYSTEM SHALL BE SUBMITTED AND APPROVED BEFORE ANY FIRESTOPPING IS INSTALLED.
4. PROVIDE A NEW MANUAL, DRY STANDPIPE SYSTEM IN THE TOWER STAIR AS SHOWN ON THE DRAWINGS IN ACCORDANCE WITH NFPA 14.

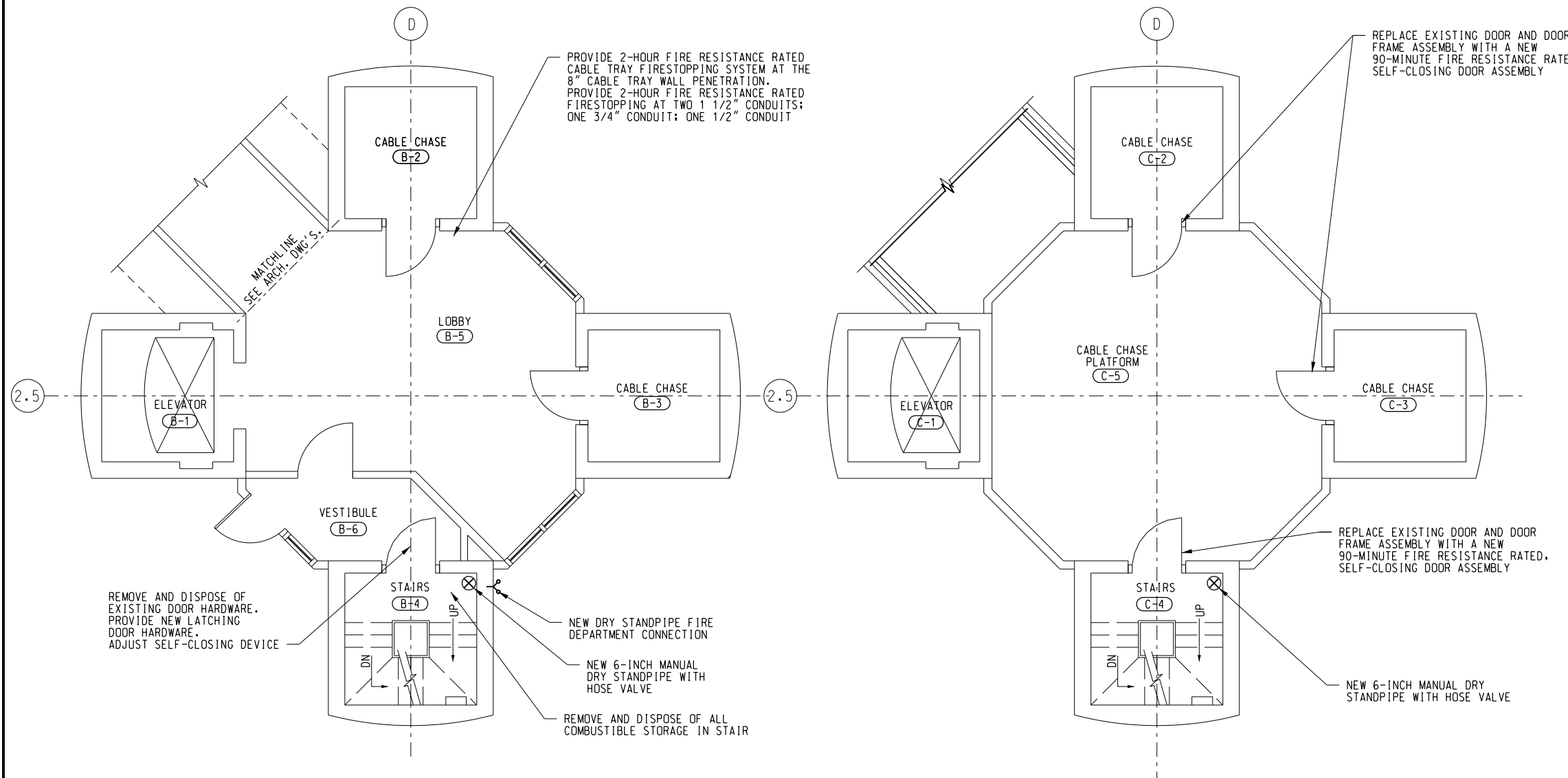

**1** GROUND LEVEL PLAN  
F101 SCALE: 1/4" = 1'-0"

**2** CABLE ACCESS LEVEL 1 - SECOND FLOOR  
F101 SCALE: 1/4" = 1'-0"

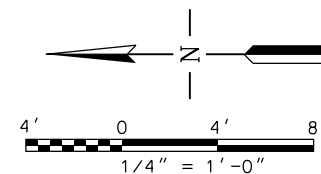

SCALES SHOWN FOR 22" X 34" SHEET. ADJUST SCALES FOR OTHER SIZES. PAGE OF

REV	APPROVED DATE	DESCRIPTION	JCN	REDLINE DATE	APVD

DEPARTMENT OF TRANSPORTATION  
FEDERAL AVIATION ADMINISTRATION

FORT LAUDERDALE AIRPORT TRAFFIC CONTROL TOWER  
MAJOR IMPROVEMENTS  
TOWER - GROUND LEVEL AND CABLE ACCESS  
LEVEL 1 PLANS

FT LAUDERDALE (INTERNATIONAL) FL

REVIEWED BY	SUBMITTED BY	APPROVED BY
DESIGNED	JWJ	ISSUED BY
DRAWN	HJM	ATLANTA TERMINAL ENGINEERING CENTER
CHECKED	JWJ	

DATE JAN 31, 2019 JCN 1508912  
DRAWING NO. FLL-D-ATCT-F101

Wiley|Wilson  
5901 Peachtree Dunwoody Rd.  
Bldg. C, Ste 515  
Atlanta, Georgia 30328-6055  
678.320.1888  
wileywilson.com  
WW JOB NUMBER: 219075.00

GEORGIA REGISTERED PROFESSIONAL ENGINEER 1/31/20 JEREMY W. JOHNSON

**NOTES**

1. ALL INTERIOR WALLS, CEILINGS, FLOORS, DOORS AND OTHER FINISHED CONSTRUCTION THAT ARE DAMAGED OR ALTERED BY THE CONTRACTOR SHALL BE RESTORED TO ORIGINAL CONDITION.
2. PRIOR TO ANY FIRESTOPPING MATERIALS OR ASSEMBLY BEING INSTALLED, THE CONTRACTOR SHALL HAVE SUBMITTED TO THE FAA RESIDENT ENGINEER MSDS OF ALL MATERIALS INTENDED FOR USE. NO SUBSTITUTIONS SHALL BE PERMITTED WITHOUT THE WRITTEN PERMISSION OF THE RESIDENT ENGINEER. REFER TO SPECIFICATION SECTION 07840 FOR APPROVED FIRESTOPPING MATERIALS AND METHODS.
3. PROVIDE UL-LISTED ASSEMBLIES OR ENGINEERED SYSTEMS FOR ALL FIRE BARRIER AND FIRESTOPPING APPLICATIONS AT ALL REQUIRED LOCATIONS. FIRESTOPPING IS ALSO REQUIRED FOR ALL PENETRATIONS MADE BY THE CONTRACTOR FOR ALL DEMO AND NEW WORK. UL CLASSIFICATION PRODUCT DATA SHEET OR MANUFACTURER'S ENGINEERED SYSTEM SHALL BE SUBMITTED AND APPROVED BEFORE ANY FIRESTOPPING IS INSTALLED.
4. PROVIDE A NEW MANUAL, DRY STANDPIPE SYSTEM IN THE TOWER STAIR AS SHOWN ON THE DRAWINGS IN ACCORDANCE WITH NFPA 14.

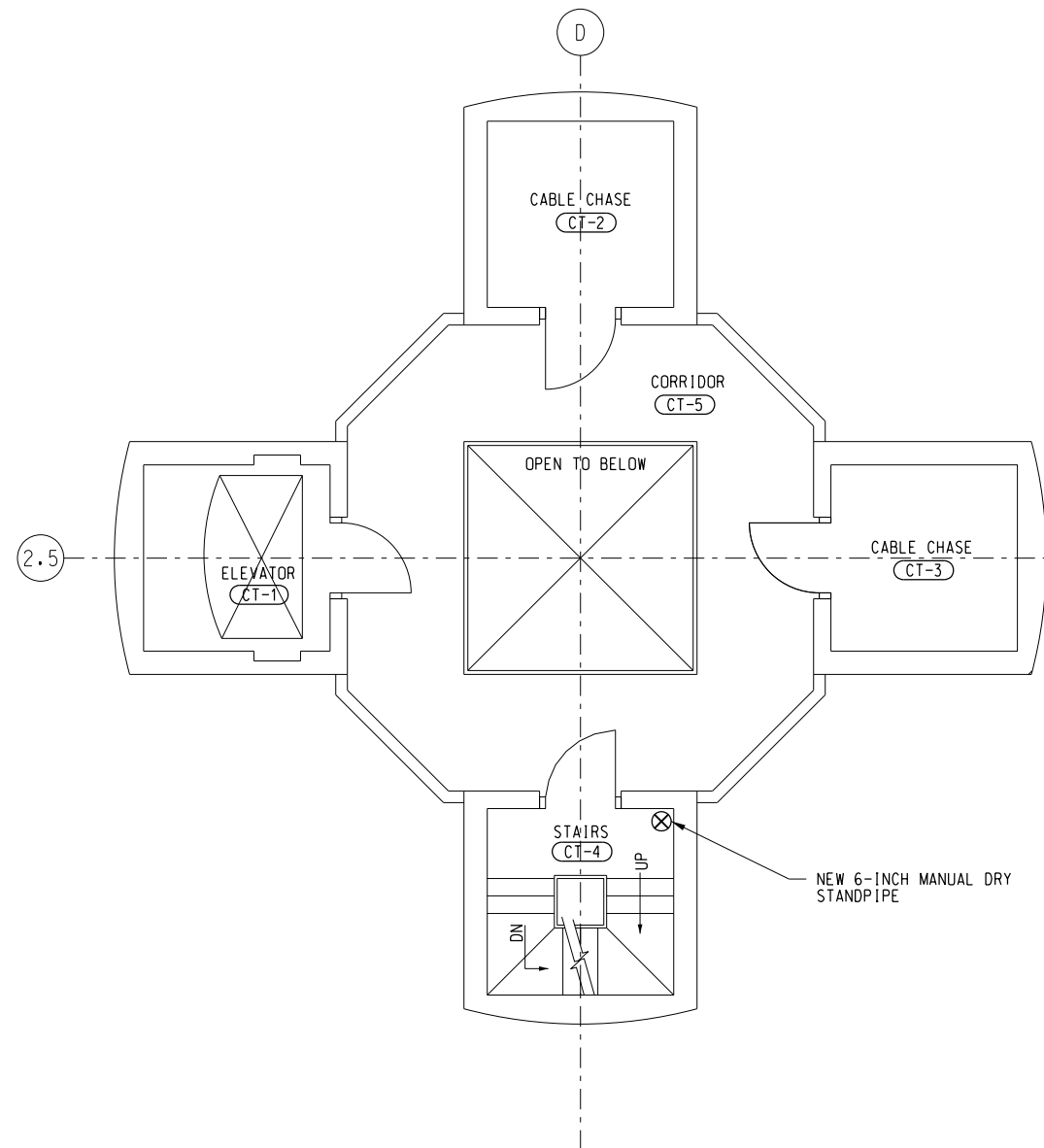

**1** CABLE ACCESS PLAN - TYPICAL  
**F102** SCALE: 1/4" = 1'-0"

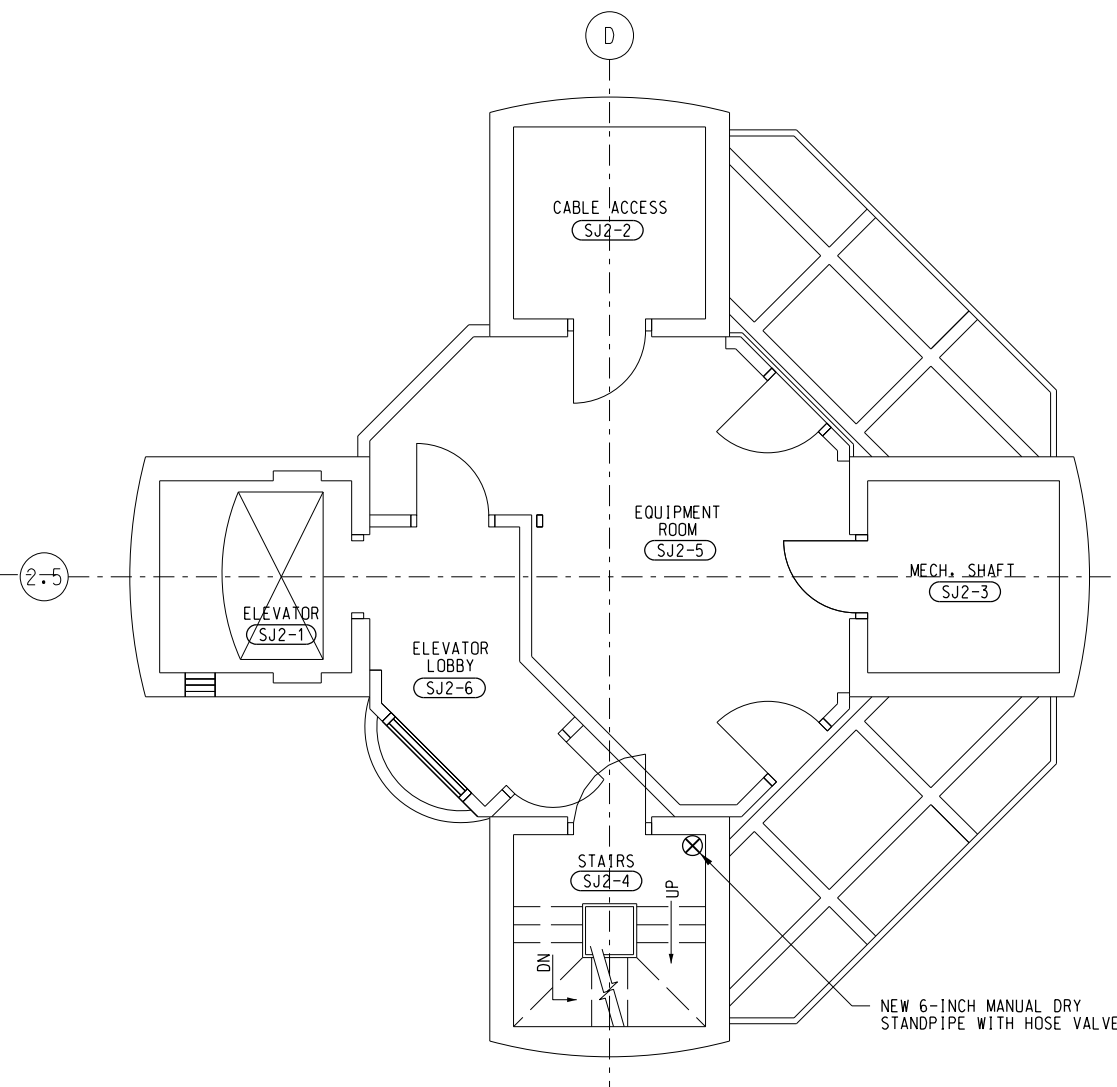

**2** SUBJUNCTION LEVEL 2 PLAN  
**F102** SCALE: 1/4" = 1'-0"

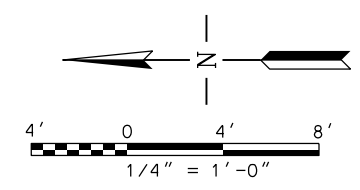

SCALES SHOWN FOR 22" X 34" SHEET. ADJUST SCALES FOR OTHER SIZES. PAGE **01** OF **01**

REV	APPROVED DATE	DESCRIPTION	JCN	REDLINE DATE	APVD
<b>DEPARTMENT OF TRANSPORTATION FEDERAL AVIATION ADMINISTRATION</b>					
<b>FORT LAUDERDALE AIRPORT TRAFFIC CONTROL TOWER MAJOR IMPROVEMENTS TOWER - CABLE ACCESS (TYPICAL) AND SUBJUNCTION LEVEL 2 PLANS</b>					
FT LAUDERDALE (INTERNATIONAL)			FL		
REVIEWED BY	SUBMITTED BY		APPROVED BY		
DESIGNED	SUBMITTER'S TITLE - CIVIL ENGINEER		APPROVER'S TITLE - MANAGER		
DRAWN	ISSUED BY	DATE	JCN	DRAWING NO	
CHECKED	ATLANTA TERMINAL ENGINEERING CENTER				

**WileyWilson**  
 5901 Peachtree Dunwoody Rd.  
 Bldg. C, Ste 515  
 Atlanta, Georgia 30328-6055  
 678.320.1888  
 wileywilson.com  
 WW JOB NUMBER: 219075.00

**FLL-D-ATCT-F102**

**NOTES**

1. ALL INTERIOR WALLS, CEILINGS, FLOORS, DOORS AND OTHER FINISHED CONSTRUCTION THAT ARE DAMAGED OR ALTERED BY THE CONTRACTOR SHALL BE RESTORED TO ORIGINAL CONDITION.
2. PRIOR TO ANY FIRESTOPPING MATERIALS OR ASSEMBLY BEING INSTALLED, THE CONTRACTOR SHALL HAVE SUBMITTED TO THE FAA RESIDENT ENGINEER MSDS OF ALL MATERIALS INTENDED FOR USE. NO SUBSTITUTIONS SHALL BE PERMITTED WITHOUT THE WRITTEN PERMISSION OF THE RESIDENT ENGINEER. REFER TO SPECIFICATION SECTION 07840 FOR APPROVED FIRESTOPPING MATERIALS AND METHODS.
3. PROVIDE UL-LISTED ASSEMBLIES OR ENGINEERED SYSTEMS FOR ALL FIRE BARRIER AND FIRESTOPPING APPLICATIONS AT ALL REQUIRED LOCATIONS. FIRESTOPPING IS ALSO REQUIRED FOR ALL PENETRATIONS MADE BY THE CONTRACTOR FOR ALL DEMO AND NEW WORK. UL CLASSIFICATION PRODUCT DATA SHEET OR MANUFACTURER'S ENGINEERED SYSTEM SHALL BE SUBMITTED AND APPROVED BEFORE ANY FIRESTOPPING IS INSTALLED.
4. PROVIDE A NEW MANUAL, DRY STANDPIPE SYSTEM IN THE TOWER STAIR AS SHOWN ON THE DRAWINGS IN ACCORDANCE WITH NFPA 14.

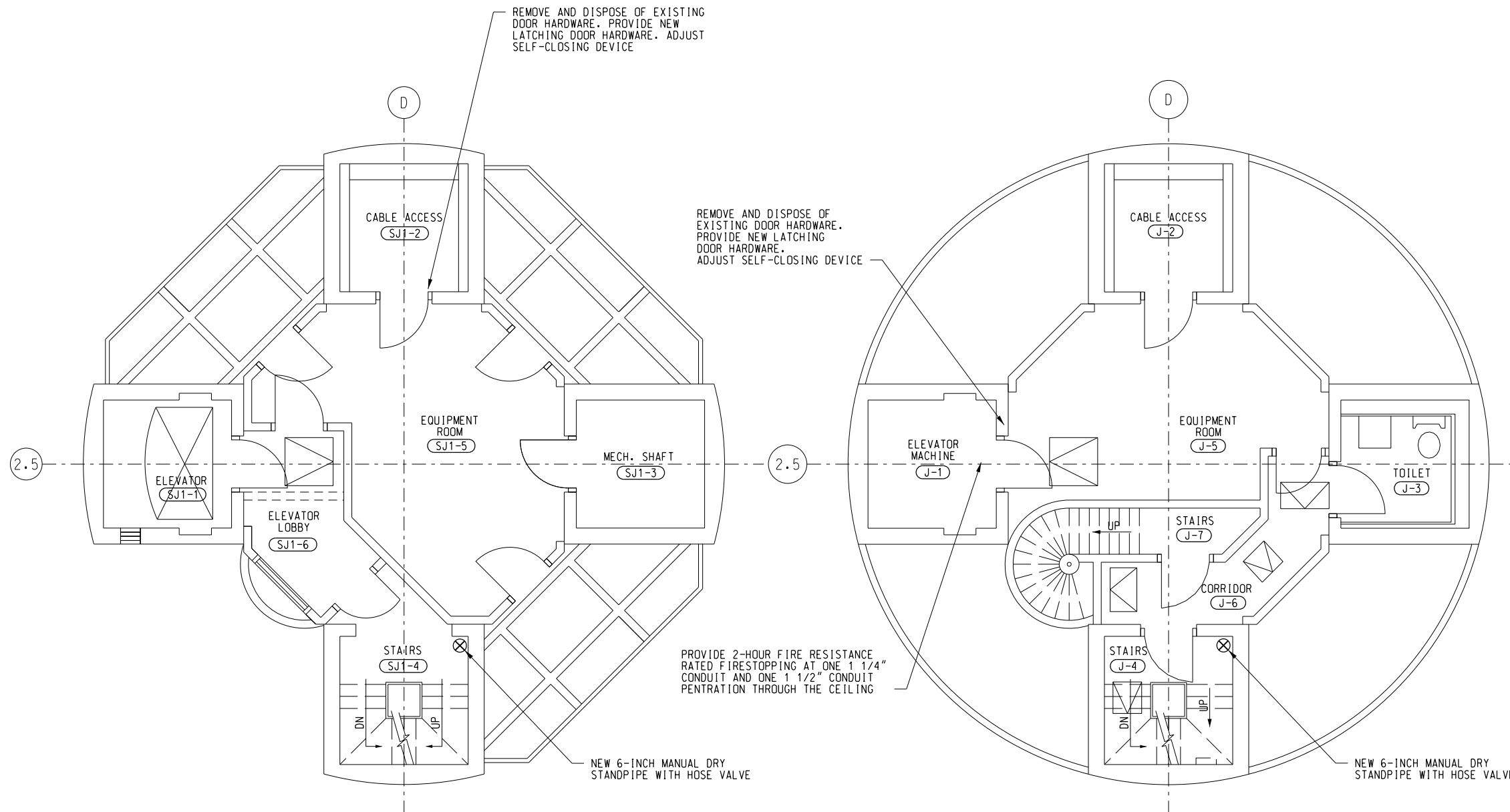

**1 SUBJUNCTION LEVEL 1**  
 F103 SCALE: 1/4" = 1'-0"

**2 JUNCTION LEVEL**  
 F103 SCALE: 1/4" = 1'-0"

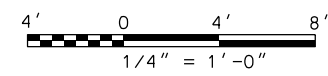

SCALES SHOWN FOR 22" X 34" SHEET. ADJUST SCALES FOR OTHER SIZES.		PAGE	OF
		REV	APPROVED DATE
		DESCRIPTION	JCN
5901 Peachtree Dunwoody Rd. Bldg. C, Ste 515 Atlanta, Georgia 30328-6055 678.320.1888 wileywilson.com WW JOB NUMBER: 219075.00		DEPARTMENT OF TRANSPORTATION FEDERAL AVIATION ADMINISTRATION FORT LAUDERDALE AIRPORT TRAFFIC CONTROL TOWER MAJOR IMPROVEMENTS TOWER - SUBJUNCTION LEVEL 1 AND JUNCTION LEVEL PLANS	REDLINE DATE APVD
FT LAUDERDALE (INTERNATIONAL) FL		SUBMITTED BY	
REVIEWED BY		APPROVED BY	
SUBMITTER'S TITLE - CIVIL ENGINEER		APPROVER'S TITLE - MANAGER	
DESIGNED BY JWJ		ISSUED BY	
DRAWN BY HJM		DATE JAN 31, 2019 JCN 1508912	
CHECKED BY JWJ		DRAWING NO. FLL-D-ATCT-F103	

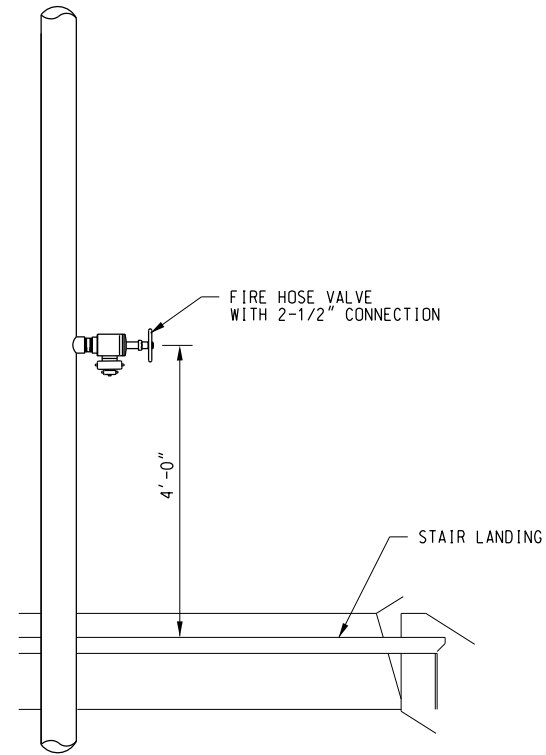

1 HOSE VALVE ASSEMBLY  
F501 SCALE: NONE

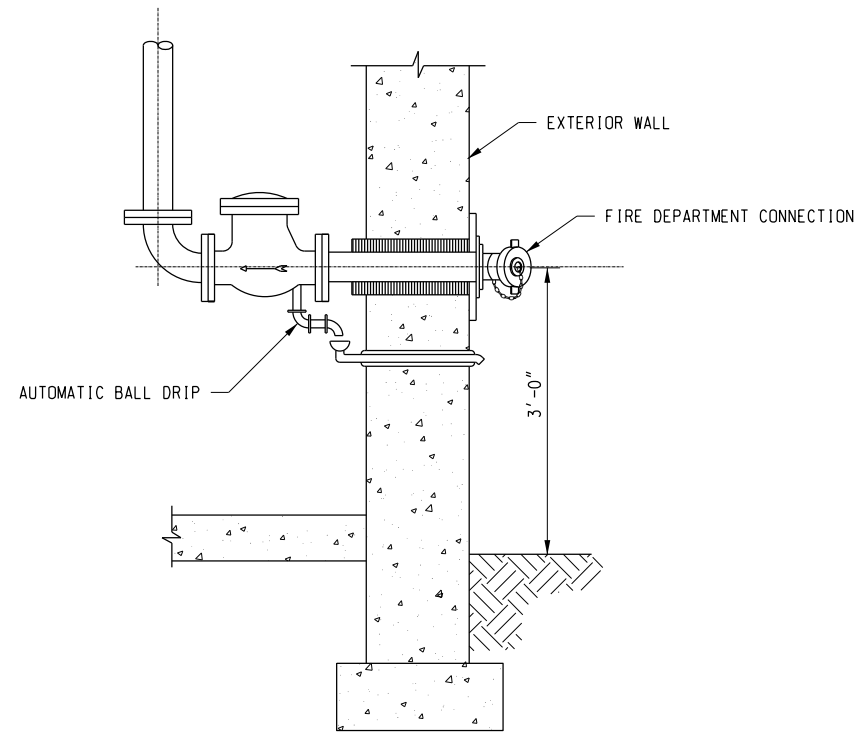

2 FIRE DEPARTMENT CONNECTION  
F501 SCALE: NONE

SCALES SHOWN FOR 22" X 34" SHEET. ADJUST SCALES FOR OTHER SIZES.				PAGE	OF
REV	APPROVED DATE	DESCRIPTION	JCN	REDLINE DATE	APVD
DEPARTMENT OF TRANSPORTATION FEDERAL AVIATION ADMINISTRATION  FORT LAUDERDALE AIRPORT TRAFFIC CONTROL TOWER MAJOR IMPROVEMENTS DETAILS					
FT LAUDERDALE (INTERNATIONAL)			FL		
REVIEWED BY	SUBMITTED BY	APPROVED BY			
		SUBMITTER'S TITLE - CIVIL ENGINEER		APPROVER'S TITLE - MANAGER	
DESIGNED	JWJ	ISSUED BY		DATE	JCN
DRAWN	HJM	ATLANTA TERMINAL ENGINEERING CENTER		JAN 31, 2019	1508912
CHECKED	JWJ			DRAWING NO	REV
				FLL-D-ATCT-F501	



**WileyWilson**  
 5901 Peachtree Dunwoody Rd.  
 Bldg. C, Ste 515  
 Atlanta, Georgia 30328-6055  
 678.320.1888  
 wileywilson.com  
 WW JOB NUMBER: 219075.00